

Data sheet

Actuators for three point control

AMV 130, AMV 140, AMV 130H, AMV 140H

Description



AMV 130/140 and AMV 130H/140H actuators are used with VZ, VZL or AHQM (DN 15-32) valves. The actuator can be used with fan coil units, induction units, small reheaters, recoolers and zone applications in which hot/cold water is the controlled medium.

Main data:

- 3-point versions
- Force switch-off at stem down position prevents overload of actuator and valve
- No tools required for mounting
- Maintenance free during lifetime
- Low noise operation
- Supplied with 1,5 m cable

Ordering

Type	Supply voltage V AC	Speed s/mm	Code No.
AMV 130	24	24	082H8036
AMV 140		12	082H8038
AMV 130H		24	082H8040
AMV 140H		12	082H8042
AMV 130	230	24	082H8037
AMV 140		12	082H8039
AMV 130H		24	082H8041
AMV 140H		12	082H8043

Spare parts

Type	Code No.
Cable (5m) - 24 V	082H8052
Cable (5m) - 230 V	082H8053

Technical data

Type		AMV 130, AMV 130H	AMV 140, AMV 140H
Power supply	V	24 AC, 230 AC; +10 to -15 %	
Power consumption	VA	1-24 V AC; 8-230 V AC	
Frequency	Hz	50/60	
Close of force	N	200	
Stroke	mm	5,5	
Speed	s/mm	24	12
Max. medium temperature inside the pipe	°C	130	
Ambient temperature		0...55	
Storage and transport temperature		-40...70	
Protection Class			
Grade of enclosure		IP 42	
Weight	kg	0,3	
- marking in accordance with standards		EMC- Directive 89/336/EEC, 92/31/EEC, 93/68/EEC, EN 61000-6-1 and EN 61000-6-3 Low Voltage Directive 73/23/EEC and 93/68/EEC, EN 60730-2-14	

Installation

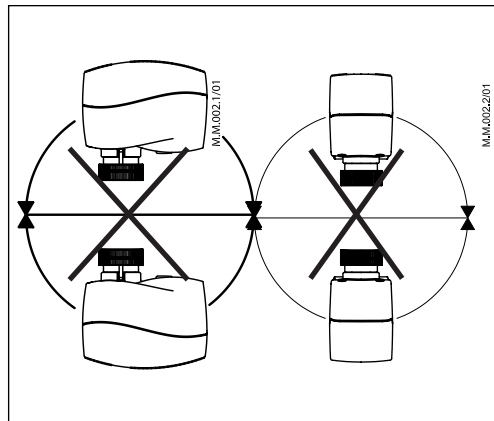

Mechanical

The actuator should be mounted with the valve stem in either horizontal position or pointing upwards.

The actuator is fixed to the valve body by means of a mounting ring which requires no tools for mounting. The ring should be tightened by hand.

Electrical

Important: It is strongly recommended that the mechanical installation is completed before the electrical installation.

Each actuator is supplied with the connecting cable for the controller.

Wiring

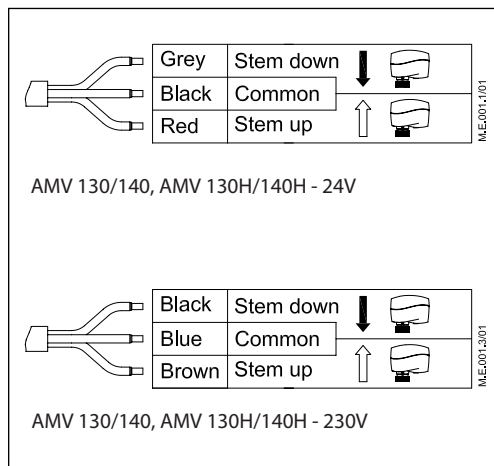

Disposal

The actuator must be dismantled and the elements sorted into various material groups before disposal.

Commissioning

The factory setting of the spindle is the fully stem up position because of easier mechanical connection of the actuator on the valve.

Installation and commissioning procedure (if required)



Do not touch anything on the PCB! Before removing the cover in need of hand operation with Allen key power supply must be disconnected. Lethal voltage!

- 1 Check the valve's neck. The actuator should be in steam up position (factory setting). Ensure that the actuator is mounted securely on the valve body.
- 2 Energise the actuator according to the wiring diagram - see page 2.
- 3 The direction of stem movement can be observed on the position indicator.

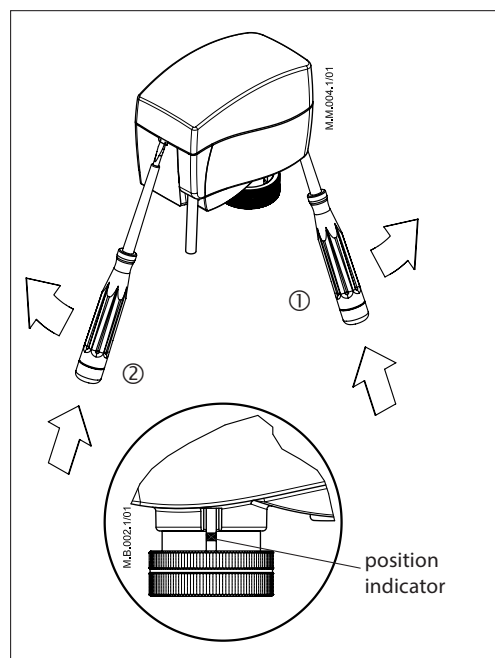

Manual override (for service purposes only)



Caution:
Do not manually operate the drive under power!

AMV 130, AMV 140

- 1 Remove the cover.
- 2 Insert the Allen key 6 into the spindle.
- 3 Press and hold the button (on the bottom side of the actuator) during manual override.
- 4 Pull out the tool.
- 5 Place cover back on the actuator.

Remark:

A "click" sound after energizing the actuator means that the gear wheel has jumped into normal position.

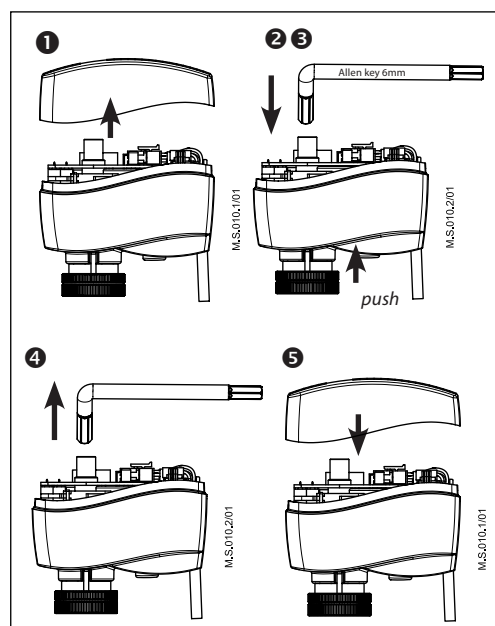

AMV 130H, AMV 140H

- 1 Press and hold the button (on the bottom side of the actuator) during manual override.

Remark:

A "click" sound after energizing the actuator means that the gear wheel has jumped into normal position.

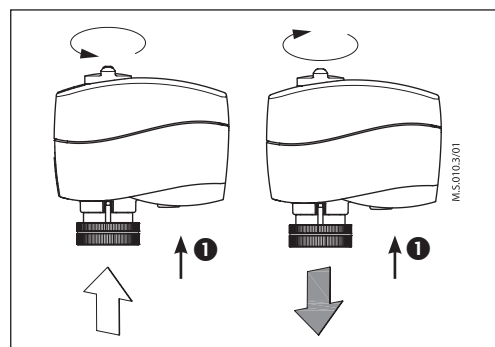

Actuator - valve combinations

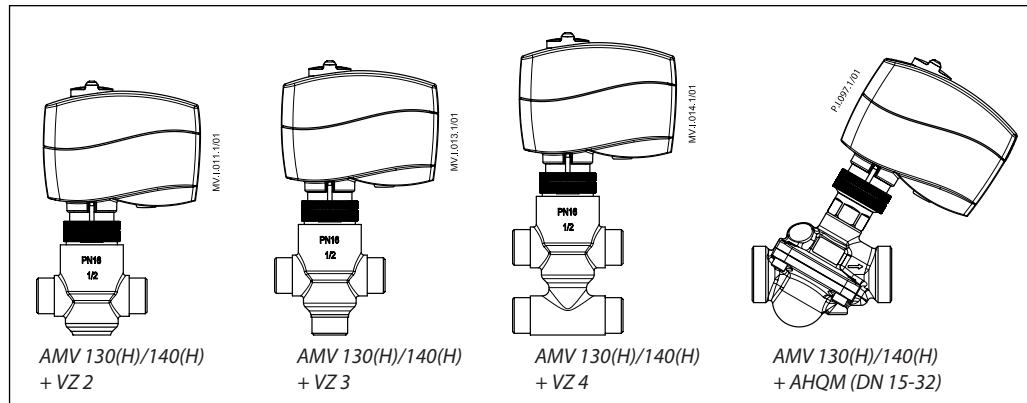

Dimensions

