

Data sheet

Flow controller with integrated control valve (PN 16, 25, 40*)

AFQM, AFQM 6 - return and flow mounting

Description

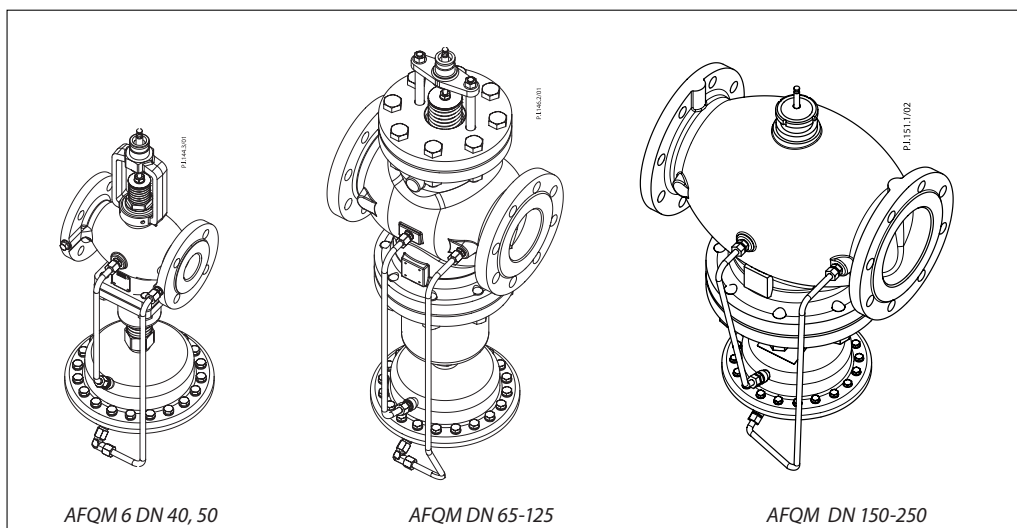

AFQM(6) is a self-acting flow controller with integrated control valve with full authority, primarily for use in district heating systems. The controller closes when set max. flow is exceeded. In combination with Danfoss electrical actuators AMV(E) can be controlled by ECL electronic controllers.

The AFQM (6) is pressure independent which means that the control characteristic is independent from the available pressure and is not influenced by a low authority.

The controller has a control valve with adjustable flow restrictor, connection neck for electrical actuator and an actuator with one control diaphragm. Further on control valve can be:

- not pressure relieved (AFQM 6 DN 40-50) or
- pressure relieved (AFQM DN 65-250).

Controllers are used together with Danfoss electrical actuators:

- AFQM 6 PN 16/25, AFQM PN 16/25 DN 65-125 ³⁾
 - AMV(E) 65x
 - without spring return function and with manual operation:
 - AMV(E) 655
 - spring return function and manual operation:
 - AMV(E) 658 SD ²⁾
 - spring return function:
 - AMV(E) 659 SD ¹⁾
- AFQM 6 PN 16/25, AFQM PN 16/25 DN 65-125
 - AMV(E) 55, 56

- AFQM PN 16 DN 150-250
 - AMV(E) 85, 86

¹⁾ DIN approved, according to EN 1457

²⁾ not DIN approved

³⁾ For AFQM 6 PN 16/25 and AFQM PN 25/40 controllers, produced before March 2015, adapter code 065B3527 need to be separately ordered

Main data:

- DN 40-250
- k_{vs} 20-400 m³/h
- Flow range 2,2-420 m³/h
- PN 16, 25
- * PN 40 on special request
- Flow restrictor Δp_b : 0,2 or 0,5 bar
- Temperature:
 - Circulation water / glycolic water up to 30 %:
 - 2 ... 150 °C for DN 40-125
 - 2 ... 140 °C for DN 150-250
- Connections:
 - Flange
- AFQM 6 and AFQM PN 25 combined with AMV(E) 659 SD have been DIN approved according to EN 14597.

Ordering

Example:
Flow controller with integrated control valve, DN 65, k_{vs} 50, PN 16, flow restrictor Δp_b 0,2 bar, T_{max} 150 °C, flange

- 1x AFQM DN 65 controller
Code No.: **003G6056**

The controller will be delivered completely assembled, inclusive impulse tubes between valve and actuator. Electrical actuator AMV(E) must be ordered separately.

AFQM 6 Controller

Picture	DN	k_{vs} m ³ /h	PN	Connection	Code No.
	40	20	16	Flange EN 1092-1	003G1082
	50	32			003G1083
	40	20	25		003G1084
	50	32			003G1085

AFQM Controller

Picture	DN	k_{vs} (m ³ /h)	PN	Connection	Code No.	
					$\Delta p_b=0,2$ bar	$\Delta p_b=0,5$ bar
	65	50	16	Flange EN 1092-1	003G6056	003G6063
	80	80			003G6057	003G6064
	100	125			003G6058	003G6065
	125	160			003G6059	003G6066
	150	280			003G6060	003G6067
	200	320			003G6061	003G6068
	250	400	003G6062		003G6069	
	65	50	25		003G1088	—
	80	80			003G1089	
	100	125			003G1090	
	125	160			003G1091	

Service kits

Picture	Type designation	DN	k_{vs} (m ³ /h)	Code No.
	Valve insert	65/80	50/80	065B2794
		100/125	125/160	065B2795
	Control valve insert	65	50	065B2972
		80	80	065B2973

	Type designation	For controller	Δp_b (bar)	Code No.	
	Actuator	AFQM 6	AFQM	0,2	003G1024
					003G1026
			0,5	003G1027	

	Type designation	Code No.
	Connection kit AMV(E) 41x, 61x, 63x/AFQM 6	003G1425
	Connection kit AMV(E) 41x, 61x, 63x/AFQM	003G1426

Technical data
AFQM 6 valve

Nominal diameter		DN	40	50
k _{VS} value			20	32
Range of max. flow setting	Δp _b ¹⁾ = 0,2 bar	from	2,2	3,2
		to	11	16
Stroke		mm	8	12
Control valve authority		%	100	
Control characteristic			Linear ²⁾	
Cavitation factor z			0,55	0,5
Leakage acc. to standard IEC 534		% of k _{VS}	≤ 0,01	
Nominal pressure		PN	16, 25	
Min. differential pressure		bar	see remark ²⁾	
Max. differential pressure PN 16			16	
Max. differential pressure PN 25			20	
Medium			Circulation water / glycolic water up to 30%	
Medium pH			Min.7, max.10	
Medium temperature		°C	2 ... 150	
Connections			Flange	

Materials

Valve body	PN 16	Grey cast iron EN-GJL-250 (GG-25)
	PN 25	Ductile cast iron EN-GJS-400-18-LT (GGG-40.3)
Valve seat DP, CV		Stainless steel mat. No. 1.4021
Valve cone DP, CV		Stainless steel mat. No. 1.4404
Sealing DP		EPDM
Sealing CV		Metal
Pressure relieve system	Control valve insert	-
	Valve insert	Bellows (Stainless steel mat. No. 1.4571)

Note:

DP - diff. pressure controller, CV - control valve

¹⁾ Δp_b - differential pressure over flow restrictor

²⁾ Depends on the flow rate and valve k_{VS}; For Q_{set} = Q_{max} → Δp_{min} ≥ 0,5 bar; For Q_{set} < Q_{max} → Δp_{min} = $\left(\frac{Q}{k_{VS}}\right)^2 + \Delta p_b$

³⁾ Could be converted by actuator AME 65x to logarithmic

AFQM 6 Actuator

For valve	DN	40	50
Actuator size	cm ²	250	
Max. operational pressure	bar	25	
Flow restrictor diff. pressure ΔP _b		0,2	
Materials			
Housing		Stainless steel M. No. 1.0338	
Diaphragm		EPDM (Rolling; fibre enforced)	
Impulse tube		Stainless steel tube Ø10 × 0,8 mm	

Technical data (continuous)

AFQM valve

Nominal diameter		DN	65	80	100	125	150	200	250	
k _{vs} value		m ³ /h	50	80	125	160	280	320	400	
Range of max. flow setting	Δp _b ¹⁾ = 0,2 bar	from	5,6	8,0	12,6	16	30	38	56	
		to	28	40	63	80	145	190	280	
	Δp _b ¹⁾ = 0,5 bar	from	5,6	8,0	12,6	16	30	38	56	
		to	40	58	76	91	220	285	420	
Stroke		mm	12	18	20		25	27		
Control valve authority		%	100							
Control characteristic			Linear ³⁾							
Cavitation factor z			0,5	0,4	0,35	0,3	0,3	0,2	0,2	
Leakage acc. to standard IEC 534		% of k _{vs}	≤ 0,01							
Nominal pressure		PN	16, 25				16			
Min. differential pressure			see remark ²⁾							
Max. differential pressure PN 16		bar	16	16	15	15	12	10	10	
Max. differential pressure PN 25			20	20	15	15	-			
Medium			Circulation water / Glycolic water up to 30 %							
Medium pH			Min.7, max.10							
Medium temperature		°C	2 ... 150				2 ... 140			
Connections			Flange							
Materials										
Valve body		PN 16	Grey cast iron EN-GJL-250 (GG-25)							
		PN 25	Ductile iron EN-GJS-400-18-LT (GGG-40.3)			-				
Valve seat DP, CV			Stainless steel M. No. 1.4021							
Valve cone DP, CV			Stainless steel mat No. 1.4404				Stainless steel mat. No. 1.4021			
Sealing DP, CV			EPDM							
Pressure relieve system		Control valve insert	Bellows (stainless steel mat No. 1.4571)				Piston			
		Valve insert	Diaphragm (EPDM)							

Note:

DP - diff. pressure controller, CV - control valve

¹⁾ Δp_b - differential pressure over flow restrictor

²⁾ Depends on the flow rate and valve k_{vs}; For Q_{set} = Q_{max} → Δp_{min} ≥ 0,5 bar; For Q_{set} < Q_{max} → Δp_{min} = $\left(\frac{Q}{k_{vs}}\right)^2 + \Delta p_b$
³⁾ Could be converted by actuator AME 65x to logarithmic

AFQM actuator

For valve	DN	65	80	100	125	150	200	250
Actuator size	cm ²	250						
Max. operational pressure	bar	16 or 25						
Flow restrictor diff. pressure Δp _b		0,2 or 0,5						
Materials								
Housing		Stainless steel M. No. 1.0338						
Diaphragm		EPDM (Rolling; fibre enforced)						
Impulse tube		Stainless steel tube Ø10 × 0,8 mm						

Application principles

- Return mounting

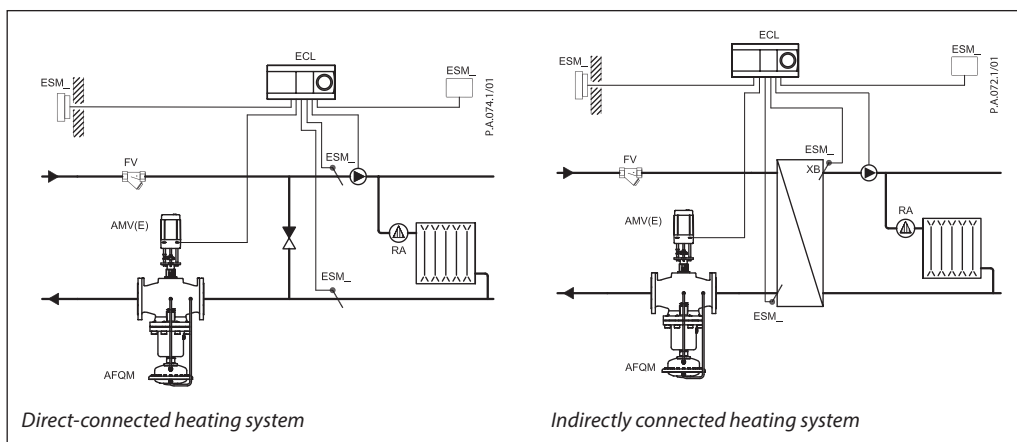

- Flow mounting

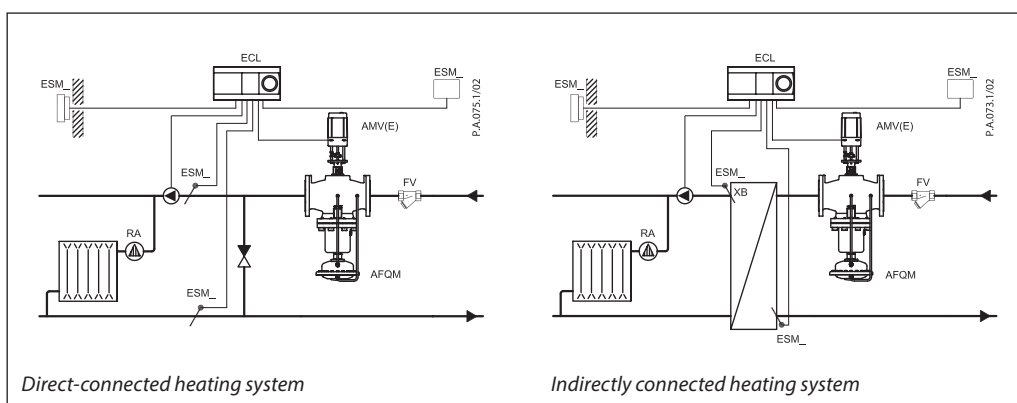

Installation positions

DN 40-80 $T_{max} \leq 120\text{ }^{\circ}\text{C}$

The controllers can be installed with (connection neck for) electrical actuator oriented horizontal or upwards.

DN 40-80 $T_{max} > 120\text{ }^{\circ}\text{C}$
DN 100-250

The controllers can be installed with (connection neck for) electrical actuator oriented upwards.

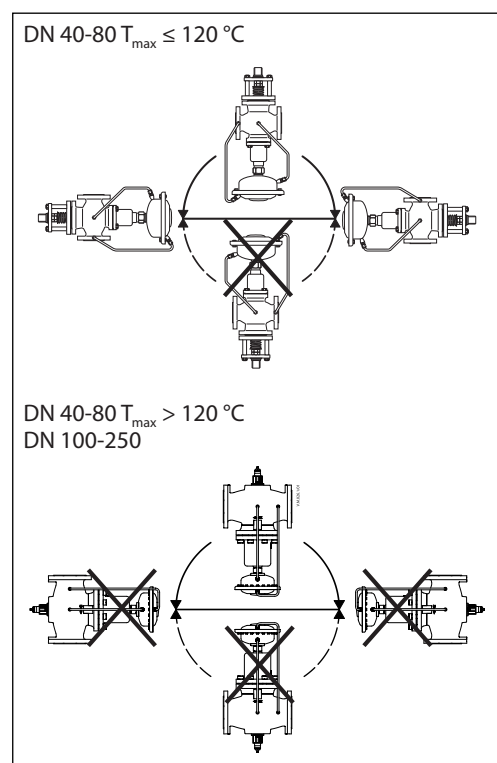

Pressure temperature diagram

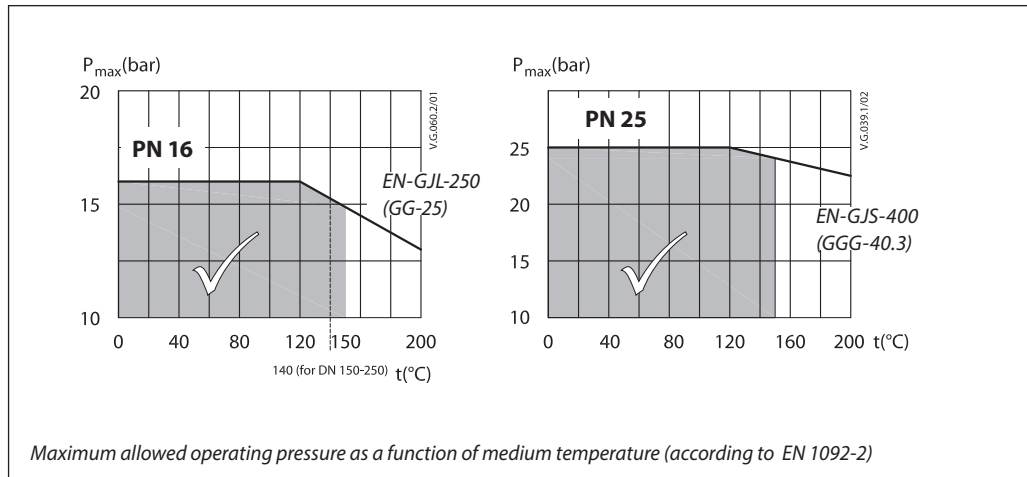

Flow diagram

Sizing and setting diagram

Relation between actual flow and number of revolutions on flow restrictor. Values given are approximate.

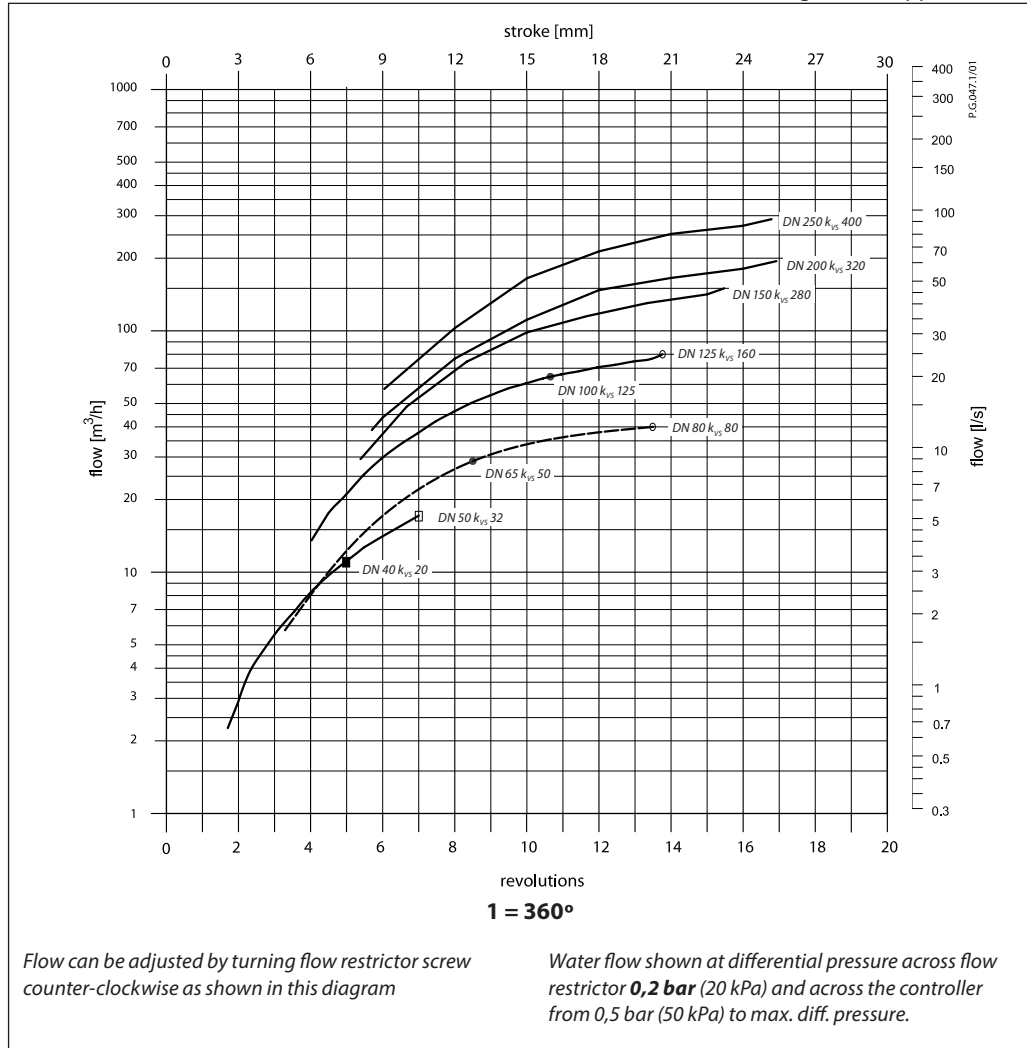

Flow diagram

Sizing and setting diagram

Relation between actual flow and number of revolutions on flow restrictor. Values given are approximate.

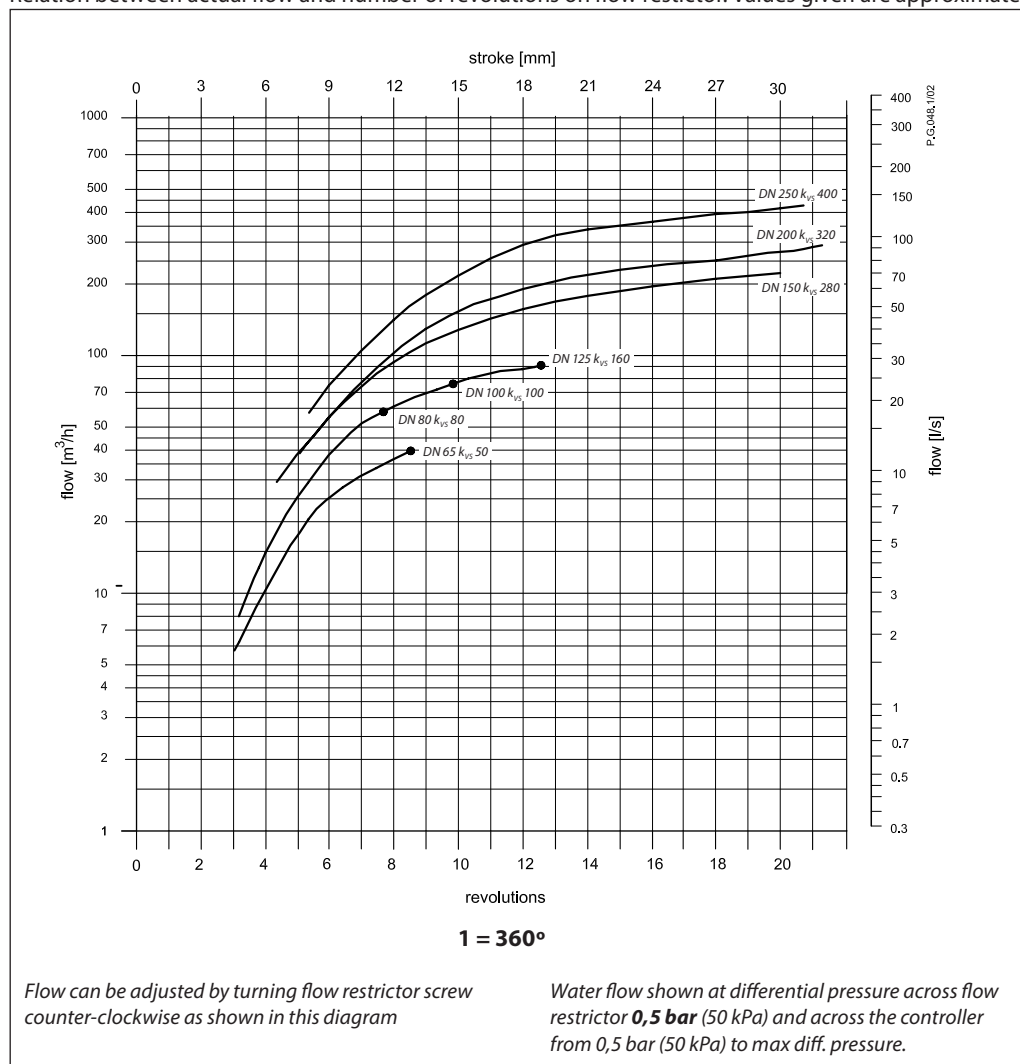

Sizing

- Directly connected heating system

Example 1

Motorised control valve (MCV) for mixing circuit in direct-connected heating systems requires differential pressure of 0,2 bar (20 kPa) and flow less than 8000 l/h.

Given data:

- $Q_{max} = 8,0 \text{ m}^3/\text{h}$ (8000 l/h)
- $\Delta p_{min} = 0,8 \text{ bar}$ (80 kPa)
- $\Delta p_{circuit}^1 = 0,1 \text{ bar}$ (10 kPa)
- $\Delta p_{MCV} = 0,2 \text{ bar}$ (20 kPa) selected

Remark:

¹⁾ $\Delta p_{circuit}$ corresponds to the required pump pressure in the heating circuit and is not to be considered when sizing the AFQM.

The total (available) pressure loss across the controller is:

$$\Delta p_{AFQM,A} = \Delta p_{min}$$

$$\Delta p_{AFQM,A} = 0,8 \text{ bar} \text{ (80 kPa)}$$

Possible pipe pressure losses in tubes, shut-off fittings, heatmeters, etc. are not included.

Select controller from flow diagram, page 7, with the smallest possible k_{VS} value considering available flow ranges.

$$k_{VS} = 20 \text{ m}^3/\text{h}$$

The min. required differential pressure across the selected controller is calculated from the formula:

$$\Delta p_{AFQM,MIN} = \left(\frac{Q_{max}}{k_{VS}} \right)^2 + \Delta p_{MCV} = \left(\frac{8,0}{20} \right)^2 + 0,2$$

$$\Delta p_{AFQM,MIN} = 0,36 \text{ bar} \text{ (36 kPa)}$$

$$\Delta p_{AFQM,A} > \Delta p_{AFQM,MIN}$$

$$0,8 \text{ bar} > 0,36 \text{ bar}$$

Solution:

The example selects AFQM 6 DN 40, k_{VS} value 20, flow setting range 2,2-11 m^3/h .

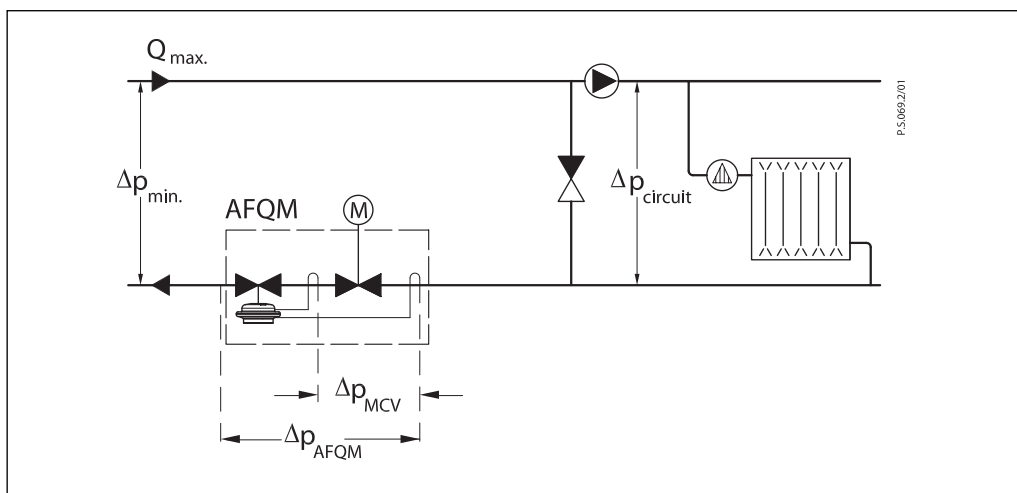
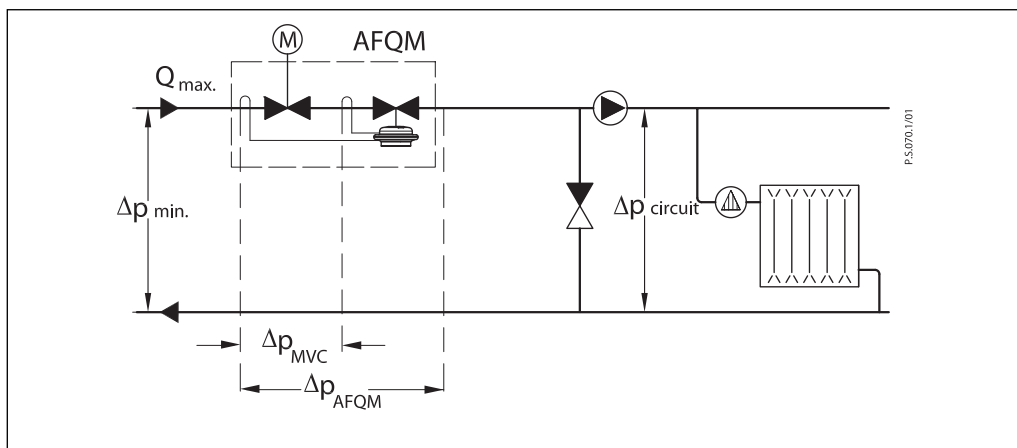

Sizing (continuous)

- Indirectly connected heating system

Example 2

Motorised control valve (MCV) for indirectly connected heating system control requires differential pressure of 0,2 (20 kPa) bar and flow less than 22.000 l/h.

Given data:

- Q_{max} = 22 m³/h (22.000 l/h)
- Δp_{min} = 0,8 bar (80 kPa)
- $\Delta p_{exchanger}$ = 0,1 bar (10 kPa)
- Δp_{MCV} = 0,2 bar (20 kPa) selected

The total (available) pressure loss across the controller is:

$$\Delta p_{AFQM,A} = \Delta p_{min} - \Delta p_{exchanger} = 0,8 - 0,1$$

$$\Delta p_{AFQM,A} = 0,7 \text{ bar (70 kPa)}$$

Possible pipe pressure losses in tubes, shut-off fittings, heatmeters, etc. are not included.

Select controller from flow diagram, page 7, with the smallest possible k_{VS} value considering available flow ranges.

$$k_{VS} = 50 \text{ m}^3/\text{h}$$

The min. required differential pressure across the selected controller is calculated from the formula:

$$\Delta p_{AFQM,MIN} = \left(\frac{Q_{max.}}{k_{VS}} \right)^2 + \Delta p_{MCV} = \left(\frac{22}{50} \right)^2 + 0,2$$

$$\Delta p_{AFQM,MIN} = 0,39 \text{ bar (39 kPa)}$$

$$\Delta p_{AFQM,A} > \Delta p_{AFQM,MIN}$$

$$0,7 \text{ bar} > 0,39 \text{ bar}$$

Solution:

The example selects AFQM DN 65, k_{VS} value 50, flow setting range 5.6-28 m³/h.

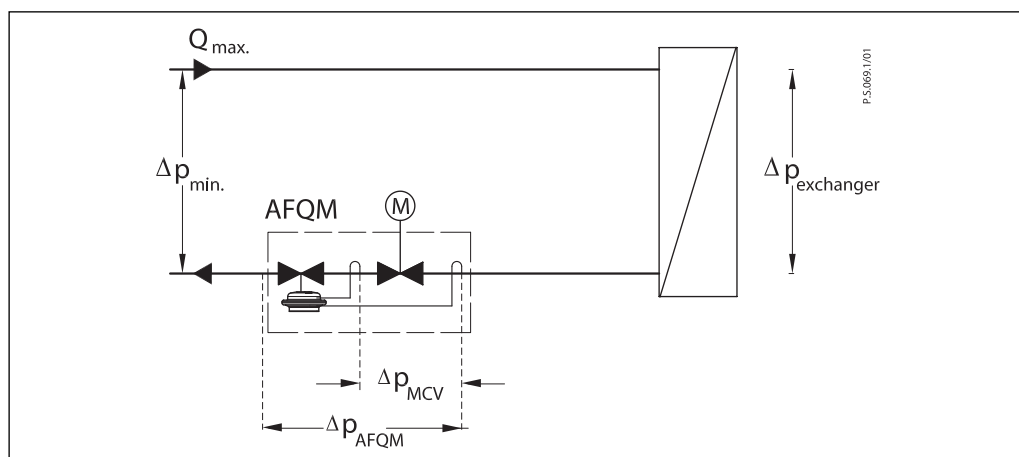
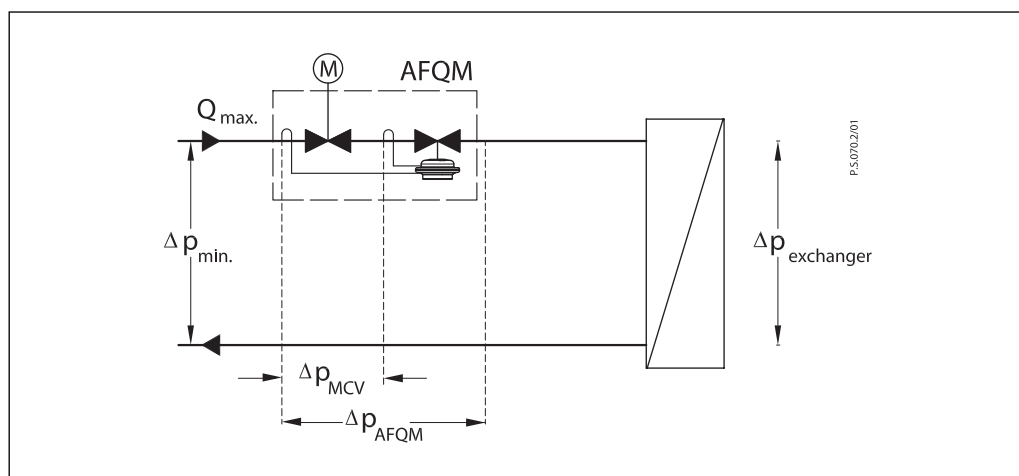

Design

1. Valve body
2. Control valve insert
3. Adjustable flow restrictor
4. Control valve stem
5. Valve seat
6. Actuator
7. Control diaphragm for flow control
8. Built-in spring for flow rate control
9. Excess pressure safety valve
10. Valve insert
11. Pressure relieved valve cone
12. Valve stem
13. Bellows for pressure relief of valve cone
14. Diaphragm for pressure relief of valve cone
15. Impulse tube
16. Union nut
17. Upper casing of diaphragm
18. Lower casing of diaphragm
19. Cover
20. Bellows for pressure relieve of control valve cone

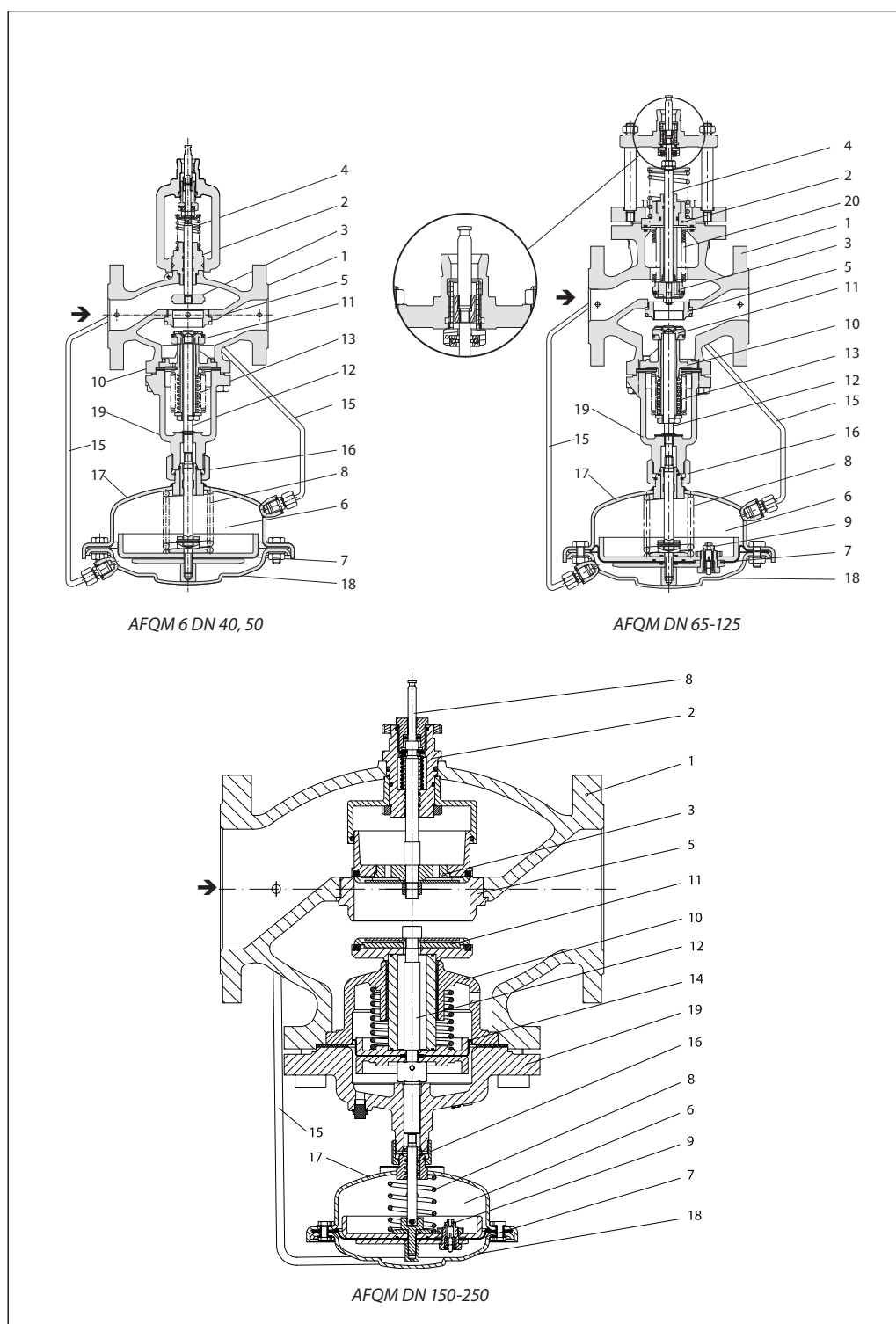

Function

Flow volume causes pressure drop across the adjustable flow restrictor. Resulting pressures are being transferred through the impulse tubes to the actuator chambers and act on control diaphragm for flow control. The flow restrictor diff. pressure is controlled and limited by means of built-in spring for flow control. Control valve closes on rising differential pressure and opens

on falling differential pressure to control max flow. Additionally the electrical actuator will operate from zero to set max. flow according to the load.

Controller AFQM is equipped with excess pressure safety valve, which protect control diaphragm for flow control from too high differential pressure.

Settings

Flow setting

Flow setting is being done by the adjustment of the flow restrictor position. The adjustment can be performed on the basis of flow adjustment diagram (see relevant instructions) and/or by the means of heat meter.

Dimensions

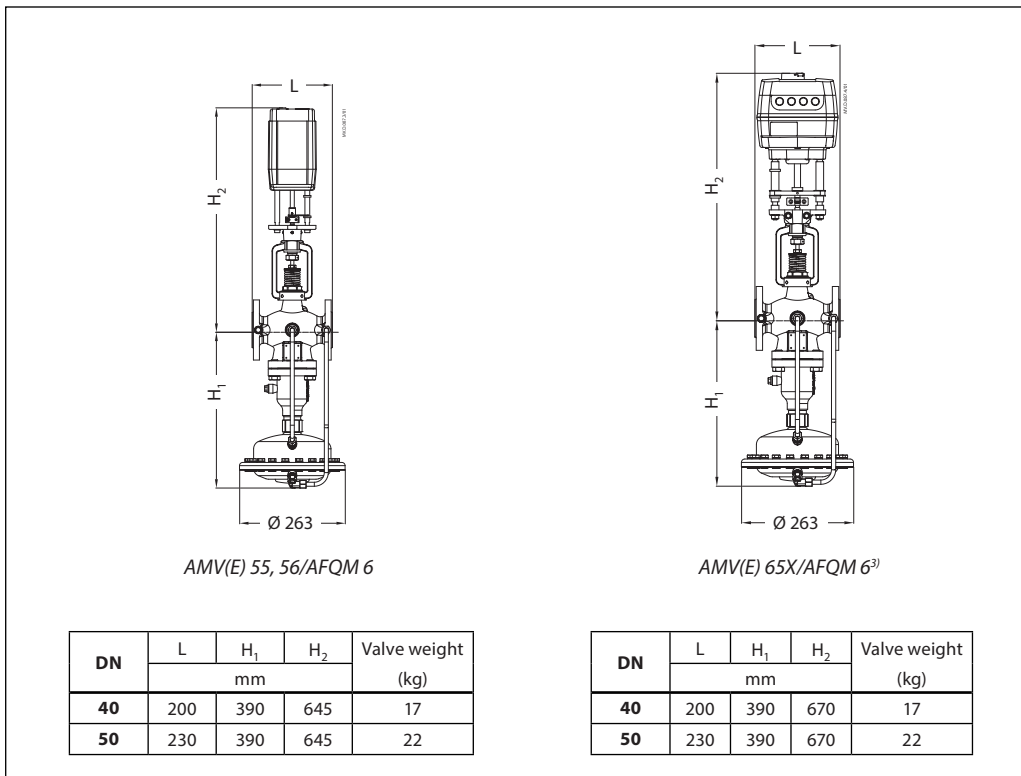

Dimensions (continuous)

