

## Data sheet

# Actuator for modulating control

## AME 438 SU – safety function (spring up)

### Description



AME 438 SU actuator is used with two and three-way valves type VRB, VRG, VF and VL up to DN 50 diameter.

The actuator has some special features:

- it automatically adapts its stroke to the valve end positions which reduces commissioning time (self stroking);
- advanced design incorporates load related 'switch-off' to ensure that actuators and valves are not exposed to overload;
- Safety function (spring up): In case of power failure or power switch off spring up function retracks actuator stem to end position; Further manual stem positioning is not disabled.

#### Main data:

- Nominal voltage:
  - 24 VAC, 50 Hz/60 Hz
- Control input signal:
  - 0(4)...20 mA
  - 0(2) ... 10 V
- Force: 450 N
- Stroke: 15 mm
- Speed: 15 s/mm
- Max. medium temperature: 150 °C
- Self stroking
- Output signal

### Ordering

#### Actuator

Type	Supply voltage	Code No.
AME 438 SU	24 VAC	082H0121

#### Accessories

Type	Code No.
Stem heater (for valves DN 15-50)	065Z0315

### Technical data

Power supply	V	24 AC, ±10%
Power consumption	VA	14
Frequency	Hz	50/60
Control input Y	V	0-10 (2-10) [Ri = 200 kΩ]
	mA	0-20 (4-20) [Ri = 500 Ω]
Output signal X	V	0-10 (2-10) [min. load = 5 kΩ]
Close of force	N	450
Max. stroke	mm	15
Speed	s/mm	15
Max. medium temperature		150
Ambient temperature	°C	0 ... 55
Storage and transport temperature		-40 ... +70
Protection class		III (24 V)
Degree of protection		IP 54
Weight	kg	2,3
- marking in accordance with standards		Low Voltage Directive (LVD) 2006/95/EC: EN 60730-1, EN 60730-2-14 EMC Directive 2004/108/EC: EN 61000-6-2, EN 61000-6-3

Installation

**Mechanical**

Use 4 mm Allan key (not part of actuator delivery) to mount actuator on the valve. Installation of the valve with the actuator is allowed in horizontal position or upwards. Installation downwards is not allowed.

The actuator must not be installed in an explosive atmosphere, at ambient temperature lower than 0 °C or at ambient temperature higher than 55 °C. It must not be subject to steam jets, water jets or dripping liquid as well.

**Note:** the actuator may be rotated up to 360° with respect to the valve stem by loosening the retaining fixture. Once the actuator is placed, retighten the fixture.

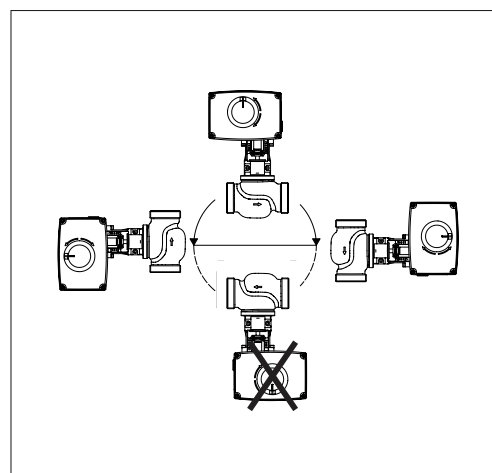

**Electrical**

Electrical connections can be accessed by removing the actuator cover. Two cable gland entries with thread (M20 x 1.5 and M16 x 1.5) are prepared for cable glands.

**Note:** Cable and cable gland used must not compromise the actuator's IP rating, and must ensure the connectors are fully strain relieved. Please observe local rules and regulations as well.

Wiring



24 V AC

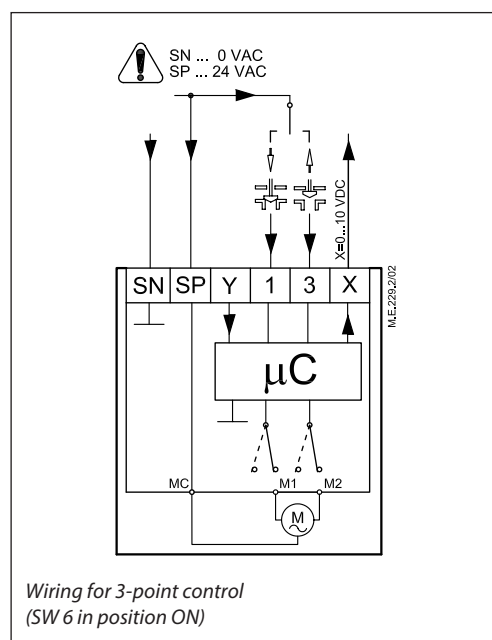
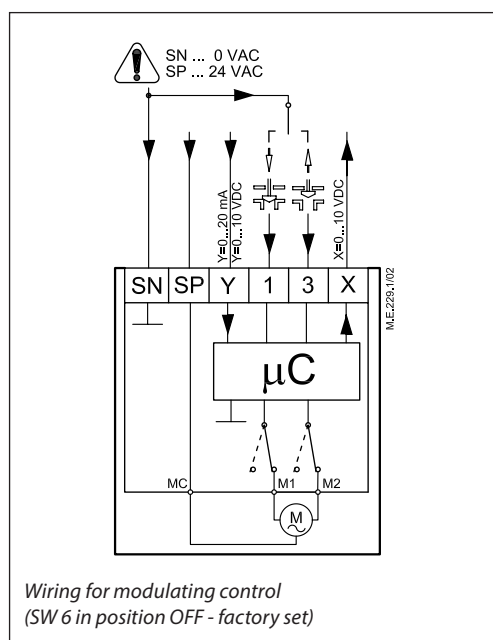

- SP** 24 V AC .....Power supply
- SN** 0 V .....Common
- Y** 0-10 V .....Input signal  
(2-10 V)  
0-20 mA  
(4-20 mA)
- X** 0-10 V .....Output signal  
(2-10 V)

Wiring length	Recommended cross-sectional area of the wiring
0-50 m	0.75 mm <sup>2</sup>
> 50 m	1.5 mm <sup>2</sup>

Disposal

The actuator must be dismantled and the elements sorted into various material groups before disposal.

**Commissioning**

Complete the mechanical and electrical installation, set DIP-switches, then perform the necessary checks and tests:

- Apply power  
Note that the actuator will now perform automatic self stroking function
- Apply the appropriate control signal and check:
  - if the valve stem direction is correct for the application and
  - the actuator drives the valve over the entire stroke length

The unit is now fully commissioned.

**Automatic self stroking feature**

The actuator automatically adapts its stroke to the valve end positions:

- when power is applied for the first time or
- afterwards by changing of DIP switch 9 setting (from OFF to ON and back to OFF)

**Testing entire valve stroke length**

The actuator can be driven to the fully-open or closed positions (depending on valve type) by connecting SN to terminals 1 or 3.

**DIP switch setting**

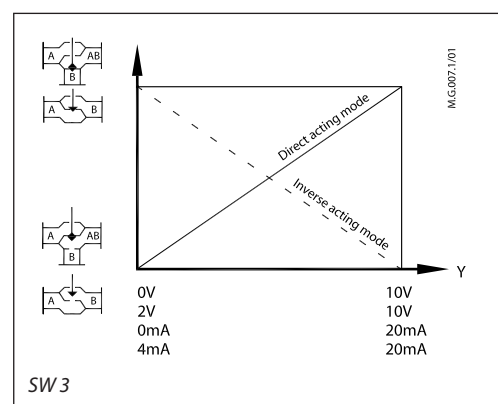
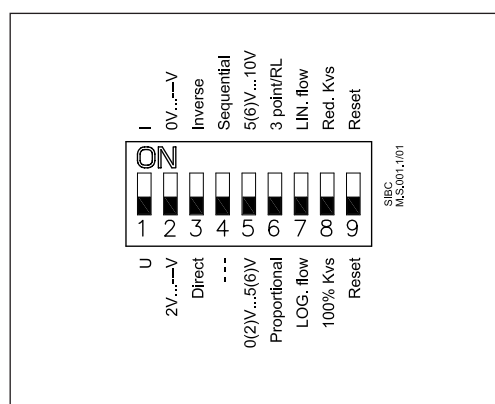

**DIP switches**

- **SW 1: U/I - Input signal type selector**
  - OFF position; voltage input is selected
  - ON position; current input is selected
- **SW 2: 0/2 - Input signal range selector**
  - OFF position; the input signal is in the range from 2-10 V (voltage input) or from 4-20 mA (current input)
  - ON position; the input signal is in the range from 0-10 V (voltage input) or from 0-20 mA (current input)
- **SW 3: D/I - Direct or inverse acting mode selector**
  - OFF position; the actuator is in direct acting mode (stem extracts as voltage increases)
  - ON position; the actuator is in inverse acting mode (stem retracts as voltage increases)
- **SW 4: —/Seq - Input signal range in sequential mode**
  - OFF position; the actuator works in complete input range 0(2)-10 V or 0(4)-20 mA
  - ON position; the actuator works in sequential range; 0(2)-5(6) V (or 0(4)-10(12) mA) or 5(6)-10 V (or (10(12)-20 mA))
- **SW 5: 0-5V/5-10V - Normal or sequential mode selector**
  - OFF position; the actuator works in sequential range 0(2)-5(6) V or 0(4)-10(12) mA
  - ON position; the actuator works in sequential range 5(6)-10 V or 10(12)-20 mA

- **SW 6: Prop./3-pnt - Modulating or 3-point mode selector**
  - OFF position; the actuator works according to control signal
  - ON position; the actuator works as 3-point actuator
- **SW 7: LOG/LIN - Equal percentage or linear flow through valve selector <sup>1)</sup>**
  - OFF position; the flow through valve is equal percentage according to control signal
  - ON position; the flow through valve is linear according to control signal
- **SW 8: 100% K<sub>vs</sub>/Reduced K<sub>vs</sub> - Flow reduction through valve selector <sup>1)</sup>**
  - OFF position; the flow through valve is not reduced
  - ON position; the flow through valve is reduced by half of increment standard K<sub>vs</sub> values (example: valve with K<sub>vs</sub> 16 and SW8 set to ON – maximum flow through the valve is K<sub>vs</sub> 13 (middle between standard K<sub>vs</sub> 16 and K<sub>vs</sub> 10))
- **SW 9: Reset**  
Change of DIP switch setting (from OFF to ON and back to OFF) starts self stroking mode

<sup>1)</sup> NOTE: To be used only in combination with valves with equal percentage characteristic.

**Led signalling/  
Actuator operating modes**

**LED operating mode indicator**

Red LED function indicator is located on PCB unit under the cover. It indicates different operating modes.

LED	Indication type	Operating mode
Red		Flashing three times per second
		Flashing once per second
		Constantly lit
Dark	No indication	No power supply

• **Self stroking mode**

Self stroking mode starts automatically when the actuator is connected to power supply for the first time. Manual start of self stroking procedure can be done with DIP switch 9. Self stroking procedure starts with extracting the actuator stem. When maximum force is detected (at the end valve position) the actuator retracts the stem until the maximum force is detected again (on the other valve end position). End positions are set and the actuator goes to normal mode and starts responding to the control signal.

• **Normal mode**

The actuator is operating automatically.

• **Error mode**

Electrical error has occurred. Check wiring and power supply or contact Danfoss support.

**Manual override**

Manual override is done by means of positioning spindle inside the actuator:

- Disconnect power signal
- Remove the actuator cover
- Insert 5 mm Allan key (not part of actuator delivery) into the top of the positioning spindle
- Turn the key against the spring (observe the rotation direction)

To hold a manual override position, the key must be wedged.

After manual override is not needed:

- Restore power signal.

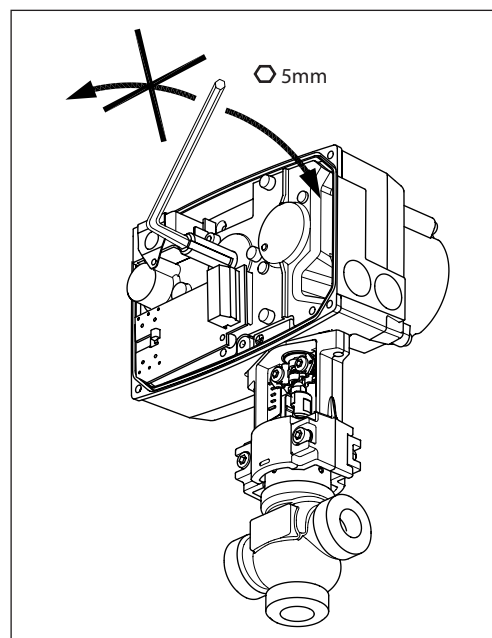

**Safety function**

The safety function will fully close the valve. The safety function unit is factory fitted to the rear of the actuator.

Valve type	Safety action will close port A-AB
VRG, VRB	SU
VL (DN 15-50)	SU
VF (DN 15-50)	SU

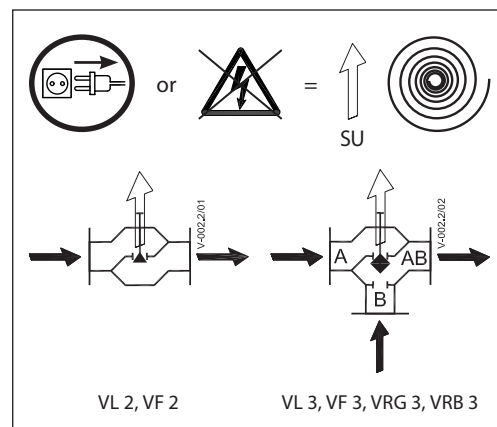

**Dimensions**

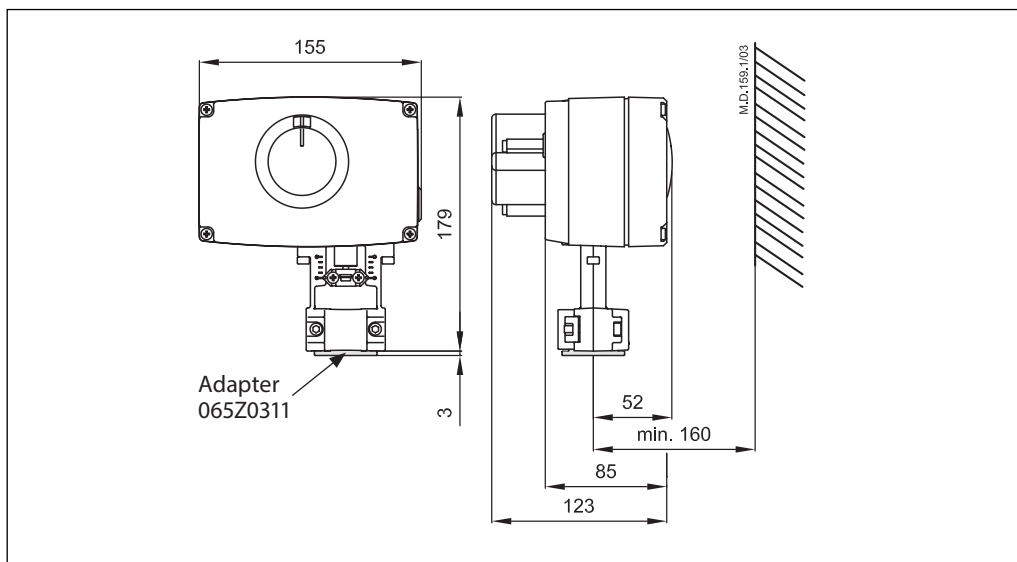

**Actuator - valve combinations**

