



Type MS05 can be combined with...



Type 8905

Online Analysis System

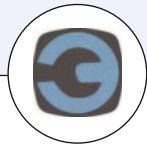

Communicator

Turbidity Sensor Cube

- Fully compatible with büS systems and a wide range of further analysis sensor cubes
- Optical sensor according to DIN EN ISO 7027 or EPA method 180.1
- Modular sensor cube for hot swap (exchange during operation)
- Minimal sample water flow needed

The device is a turbidity measurement sensor. It is used within the Online Analysis System Type 8905 by being plugged into a spare fluidic backplane slot. The device contains an optical sensor following DIN EN ISO 7027 or EPA method 180.1.

The turbidity of water needs to be analysed continuously as indicator for unwanted undissolved content in the water. Measurement prior and post filtration indicates the effect of filtration and may help to optimise the filter backwash process. In the best case it can lead to water and energy savings.

The electrical and fluidic connections are made via the connection panel of the system. The sensor cube is communicating via büS, so the recognition at the Online Analysis System is fully automatic. When plugged into a system you will find the sensor in the list of büS members for further customized adjustments.

General data		
Compatibility	with Online Analysis System Type 8905 (see corresponding data sheet)	
Materials with sensor acc. to Housing / Lever / Seal Cuvette / Valve	DIN EN ISO 7027	EPA method 180.1
	PPE+PS / PC / EPDM Glass / Silicone	PPE+PS / PC / EPDM PET, glass / Silicone
Electrical connection	Plugging/unplugging into backplane of the Type 8905	
Fluidic connection	Plugging/unplugging into backplane of the Type 8905	
Turbidity sensor acc. to DIN EN ISO 7027 EPA method 180.1	Light scattering, replaceable cuvette*	
	IR-Laser Tungsten lamp	
Turbidity measurement with sensor acc. to Measuring range Resolution Measurement deviation ¹⁾ Linearity Repeatability Response time (t90)	DIN EN ISO 7027	EPA method 180.1
	0...40 FNU	0...40 NTU
	+/- 0.0006 FNU	+/- 0.005 NTU
	±0.02 FNU or 2% of Reading, which ever is greater	±0.02 NTU or 2% of Reading, which ever is greater
	±0.5% of full scale	±0.5% of full scale
	±0.02 FNU or 2% of Reading, which ever is greater	±0.02 FNU or 2% of Reading, which ever is greater
	Depends on data filter (by default 8 samples = 1 s)	Depends on data filter (by default 8 samples = 1 s)
Maintenance	12 months nominal, depending on the water quality Regular manual or automatic cleaning (with type MZ 20)	
Type of medium pH value	Water without particles: drinking water, industrial water pH 4...pH 9	
Sample water temperature	+3...+40°C (+37...+104°F)	
Sample water pressure	PN3	
Sample water flow range	> 6 l/h	
Sample water filter	> 100 µm	

* Only for sensor acc. to DIN EN ISO 7027 and only by Bürkert qualified staff - contact your nearest Bürkert facility

¹⁾ = "measurement bias" as defined in the standard JCGM 200:2012

Environment	
Ambient temperature	+3...+40°C (+37...+104°F)
Relative humidity	< 90%, without condensation
Height above sea level	max. 2000 m
Electrical data	
Operating voltage	24 V DC through the backplane of the system Type 8095 via büS
Power consumption	0.8 VA
Internal communication	through büS (Bürkert bus)
External communication by status LED	According to NAMUR NE 107
Standards, directives and certifications	
Protection class acc. to EN 60529	IP65, when plugged in the fluidic backplane IP20, as standalone product
Standard and directives CE	The applied standards, which verify conformity with the EU Directives, can be found on the EU Type Examination Certificate and/or the EU Declaration of conformity (if applicable)
Certification UL-Recognized for US and Canada 	pending

Design and principle of operation

The sensor cube gets the sample water through the fluidic backplane, in which it is plugged in. The measurement is based on the detection of scattered light in an arrangement of 90° to the incident beam. The sample is flowing through a cuvette in glass or in glass/PET.

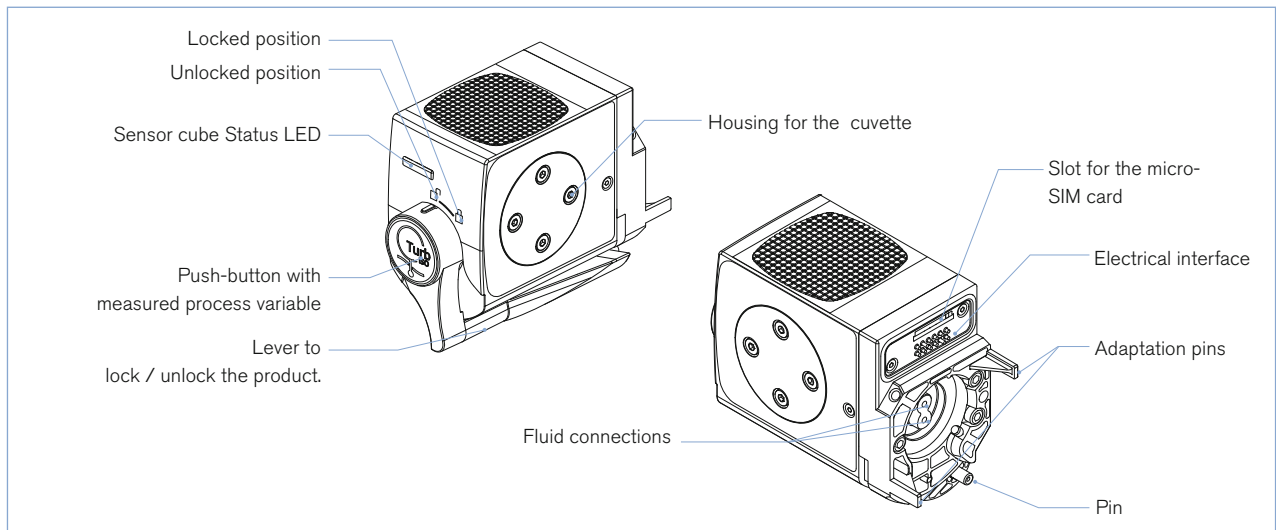

Installation into the Online Analysis System Type 8905

To operate a turbidity sensor cube it is necessary that a spare fluidic backplane site is available. It can be installed in a compact system Type 8905 or in a customized version.

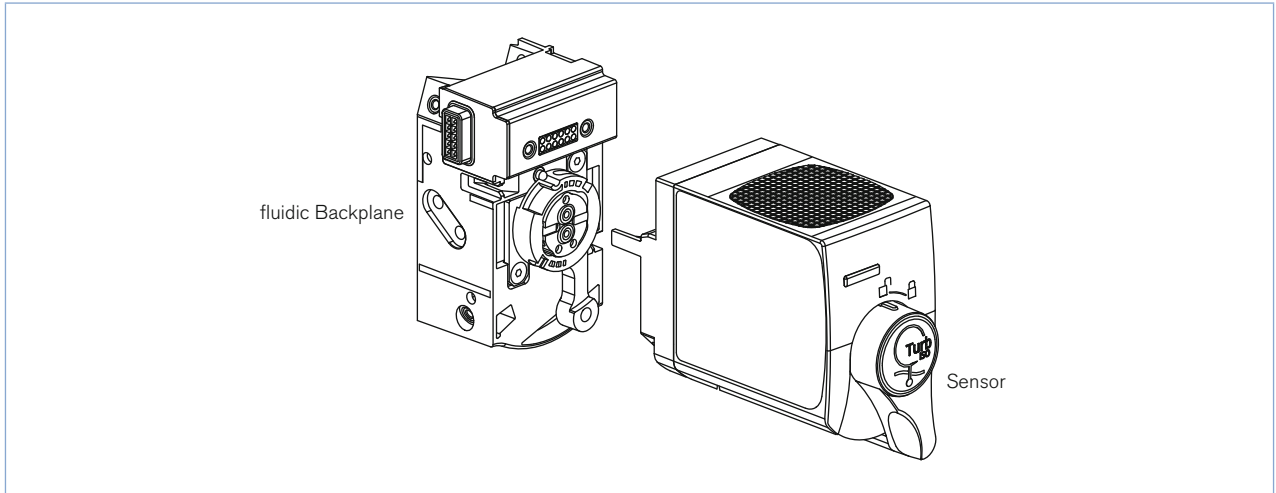

Dimensions [mm]

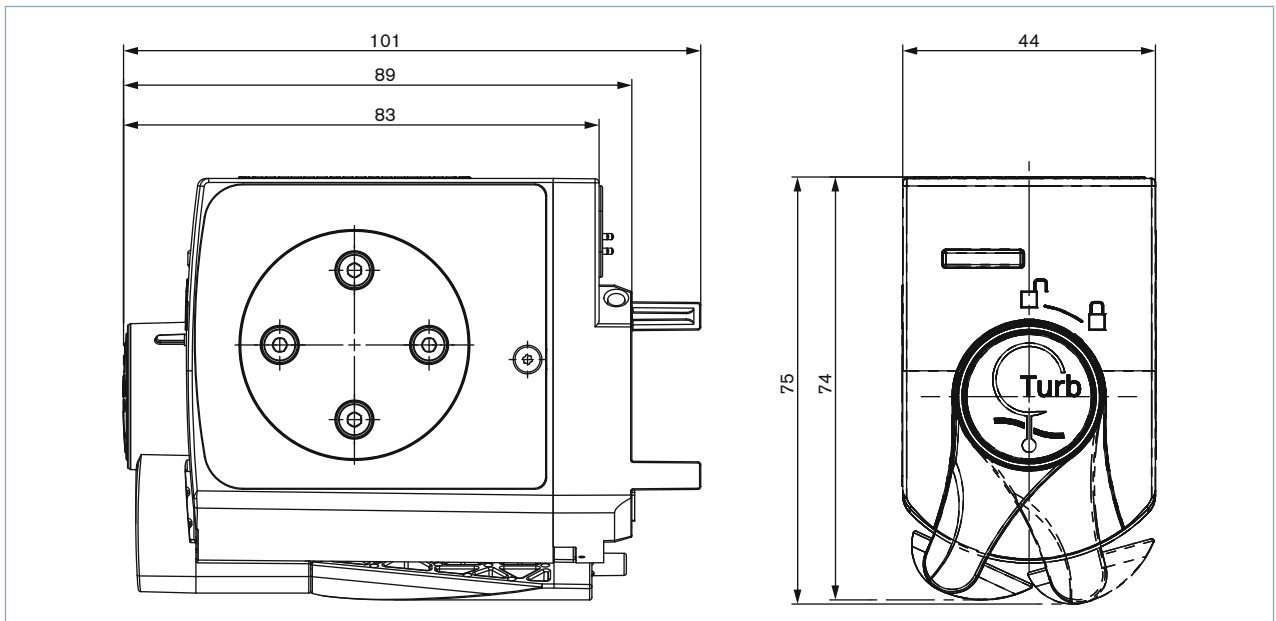

Ordering information and chart - Turbidity sensor cube

The turbidity sensor cube must be operated within a system.
Please refer to the order information for Online Analysis System Type 8905  or contact your Bürkert representative.

Description	Item no.
Turbidity sensor cube - DIN EN ISO 7027	567 634
Turbidity sensor cube - EPA method 180.1	567 635

Ordering chart - accessories and spare parts

Description	Item no.
 Type MZ20 Cleaning system, 2 solutions	567 124



DTS 1000220812 EN Version: G Status: RL (released | freigegeben | validé) printed: 22.09.2017

To find your nearest Bürkert facility, click on the orange box →

www.burkert.com

In case of special application conditions,
please consult for advice.

Subject to alteration.
© Christian Bürkert GmbH & Co. KG

1611/7_EU-en_00895267