

# Slim Line (SL/SLX) Series Industrial Ethernet Switches & Media Converter

Hardware Guide | September 2020  
LP0977 | Revision B



## **COPYRIGHT**

©2014-2020 Red Lion Controls, Inc. All rights reserved. Red Lion and the Red Lion logo are registered trademarks of Red Lion Controls, Inc. All other company and product names are trademarks of their respective owners.

Red Lion Controls, Inc.  
20 Willow Springs Circle  
York, PA 17406

## **CONTACT INFORMATION:**

### **AMERICAS**

Inside US: +1 (877) 432-9908

Outside US: +1 (717) 767-6511

**Hours:** 8 am-6 pm Eastern Standard Time  
(UTC/GMT -5 hours)

### **ASIA-PACIFIC**

Shanghai, P.R. China: +86 21-6113-3688 x767

**Hours:** 9 am-6 pm China Standard Time  
(UTC/GMT +8 hours)

### **EUROPE**

Netherlands: +31 33-4723-225

France: +33 (0) 1 84 88 75 25

Germany: +49 (0) 1 89 5795-9421

UK: +44 (0) 20 3868 0909

**Hours:** 9 am-5 pm Central European Time  
(UTC/GMT +1 hour)

Website: [www.redlion.net](http://www.redlion.net)

Support: [support.redlion.net](http://support.redlion.net)

## Table of Contents

<b>Preface .....</b>	<b>1</b>
<b>Section 1 General Information .....</b>	<b>3</b>
<b>Section 2 LED Indicators .....</b>	<b>7</b>
<b>Section 3 Installation .....</b>	<b>9</b>
<b>Section 4 Power Wiring.....</b>	<b>21</b>
<b>Section 5 Communication Wiring .....</b>	<b>27</b>
<b>Section 6 Technical Specifications.....</b>	<b>31</b>
<b>Section 7 Service Information .....</b>	<b>35</b>



## Preface

### This manual applies to the following products:

- **SL-2ES-#** 2-port unmanaged Ethernet media converter
- **SLX-3ES-#** 3-port unmanaged Ethernet media converter
- **SLX-3EG-1** 3-port unmanaged Gigabit Ethernet converter
- **SLX-5EG-1** 5-port unmanaged Gigabit Ethernet switch
- **SLX-5EG-2SFP** 5-port unmanaged Gigabit Ethernet switch with 2 fiber SFPs
- **SL/SLX-5ES-#** 5-port unmanaged Ethernet switch with 5 10/100 ports
- **SL/SLX-6ES-#** 6-port unmanaged Ethernet switch
- **SL/SLX-8ES/9ES-#** 8/9-port unmanaged Ethernet switch with 8 or 9 10/100 ports
- **SLX-8MS-#** 8-port managed Ethernet switch with 8 10/100 ports
- **SLX-8MG-1** 8-port managed Ethernet switch with 8 Gigabit ports
- **SLX-10MG-1** 10-port managed Gigabit Ethernet switch with 10 ports
- **SLX-16MS-1** 16-port managed Ethernet switch with 16 10/100 ports
- **SLX-18MG-1** 18-port managed Gigabit Ethernet switch with 18 ports

**FCC Statement** - This equipment has been tested and found to comply with the limits for a Class B digital device, pursuant to Part 15 of the FCC Rules. These limits are designed to provide reasonable protection against harmful interference in a residential installation. This equipment generates, uses and can radiate radio frequency energy and, if not installed and used in accordance with the instructions, may cause harmful interference to radio communications. However, there is no guarantee that interference will not occur in a particular installation. If this equipment does cause harmful interference to radio or television reception, which can be determined by turning the equipment off and on, the user is encouraged to try to correct the interference by one or more of the following measures: Reorient or relocate the receiving antenna; Increase the separation between the equipment and receiver; Connect the equipment into an outlet on a circuit different from that to which the receiver is connected; Consult the dealer or an experienced radio/TV technician for help.



## Section 1 General Information

### Overview

This manual will help you install and maintain these industrial Ethernet switches. Installation of these switches is very easy and they will begin to operate as soon as they are powered up. For the unmanaged models (denoted by ES or EG in their part number) there are no user settings so they are truly plug and play. The managed models (denoted by MS or MG in their part number) will act as unmanaged switches until they are configured otherwise. Refer to the managed switch software manual for configuration of advanced network functionality.

**Note:** This manual only covers the installation and wiring of these switches. For the managed models refer to the separate **Software User Manuals** for details on configuring and using any of the management functions such as SNMP, RSTP, IGMP, VLANs, security, port mirroring and much more.

**Note:** This Equipment is Suitable for Use in Class I, Division 2, Groups A, B, C, D or Non Hazardous Locations Only

### Operation

Unlike an Ethernet hub that broadcasts all messages out all ports, these industrial Ethernet switches will intelligently route Ethernet messages only out the appropriate port. The major benefits of this are increased bandwidth and speed, reduction or elimination of message collisions, and deterministic performance when tied with real-time systems.

These industrial Ethernet switches can support 10BaseT (10 Mbps), 100BaseT (100 Mbps) and 1000BaseT (1000 Mbps) on their RJ45 ports (depending on the model). Each of these ports will independently auto-sense the speed/duplex, mdi/mdix-crossover and polarity allowing you to use straight, crossed or even mis-wired cables. Some models also have one or more fiber optic ports for making noise immune connections up to 120 km.

### Performance Specifications

These general specifications apply to these industrial Ethernet switches. Refer to Section 6 for complete technical specifications.

<b>Number of ports</b>	2, 3, 5, 6, 8, 9, 10, 16 or 18 Ethernet ports
<b>Ethernet Switch Type</b>	Unmanaged (ES/EG models) or managed (MS/MG models)
<b>Ethernet Switch Mode</b>	Store and forward, wire-speed, non-blocking
<b>Ethernet Protocols</b>	All standard IEEE 802.3 protocols supported
<b>RJ45 Ports Speed</b>	10/100 or 10/100/1000 Mbps
<b>RJ45 Ports Operation</b>	Auto-negotiation, auto-mdi/mdix-crossover and auto-polarity
<b>Fiber Optic Port Speed</b>	100 Mbps (SC or ST) or 1000 Mbps (SFP/LC)
<b>Fiber Optic Type</b>	Multimode, singlemode, long-haul or special application

### Safety Standards

These industrial Ethernet Switches meet the following standards plus others:

**Note:** Some ratings may be pending on newer models. Contact Red Lion for the latest info.



#### Electrical safety –

- CE per Low Voltage Directive and IEC61010-1
- UL508
- CSA per C22.2/142

See warnings below.



Install the Managed Switches in accordance with local and national electrical codes.



**Lightning Danger:** Do not work on equipment during periods of lightning activity. Do not connect a telephone line into one of the Ethernet RJ45 connectors.



**EMC (emissions and immunity) –**

- CE per the EMC directive, EN 55022, EN 61000-6-2/4
- FCC part 15 and ICES 003; Class B. **See FCC statement on previous page.**



**Marine, maritime and offshore –**

These devices, when installed in an appropriately IP rated enclosure, comply with the ABS standards which is similar to DNV No. 2.4 and equivalent Lloyds. **Please reference product datasheet for individual specifications and agency certifications. See warning below.**



**For marine and maritime compliance, do not install this product within 5 meters of a standard or a steering magnetic compass.**



**WEEE compliance –**

These devices comply with the WEEE directive. Do not throw away these devices in the standard trash. Contact Red Lion regarding proper disposal.

✓ RoHS

**RoHS compliance –**

These devices comply with the RoHS directive and are considered lead and other hazardous substance free.



**Hazardous Locations –**



- CE per ATEX directive and IEC60079-0,-15 (Zone 2)
- ISA12.12.01 (Class I, Div. 2), Groups A,B,C,D
- CSA per C22.2/213 (Class 1, Div. 2), Groups A,B,C,D



**See warnings below.**



## **INSTALLATION AND HAZARDOUS AREA WARNINGS:**

These products should not be used to replace proper safety interlocking. No software-based device (or any other solid-state device) should ever be designed to be responsible for the maintenance of consequential equipment or personnel safety. In particular, **Red Lion disclaims any responsibility for damages, either direct or consequential, that result from the use of this equipment in any application.**

All power, input and output (I/O) wiring must be in accordance with Class I, Division 2 wiring methods and in accordance with the authority having jurisdiction. This equipment is suitable for use in Class I, Division 2, Groups A, B, C, D or non-hazardous locations only.



**WARNING  
(EXPLOSION HAZARD)**

SUBSTITUTION OF ANY COMPONENTS MAY IMPAIR SUITABILITY FOR CLASS 1, DIVISION 2 (ZONE 2).



**WARNING  
(EXPLOSION HAZARD)**

WHEN IN HAZARDOUS LOCATIONS, DISCONNECT POWER BEFORE REPLACING OR WIRING UNITS.



**WARNING  
(EXPLOSION HAZARD)**

DO NOT DISCONNECT EQUIPMENT UNLESS POWER HAS BEEN SWITCHED OFF OR THE AREA IS KNOWN TO BE NONHAZARDOUS.



**WARNING  
(EXPLOSION HAZARD)**

IN HAZARDOUS OR POTENTIALLY HAZARDOUS LOCATIONS, DO NOT SEPARATE ANY PART OF THE UNIT WHEN ENERGIZED. USE THE UNIT FOR INTERNAL CONNECTIONS ONLY.

## **INSTRUCTIONS D'INSTALLATION ET D'UTILISATION:**

Ces produits ne doivent pas être utilisés pour remplacer le verrouillage de sécurité approprié. Aucun dispositif basé sur un logiciel (ou tout autre dispositif à l'état solide) devraient jamais être conçus pour être responsable de l'entretien de l'équipement consécutifs ou la sécurité du personnel. En particulier, Red Lion décline toute responsabilité pour les dommages, directs ou indirects, résultant de l'utilisation de cet équipement dans n'importe quelle application.

Tout courant, câblage entrée et sortie (I / O) doit être conforme aux méthodes de câblage à la Classe I, Division 2 et conformément à l'autorité compétente. Cet équipement est adapté à une utilisation en Classe I, Division 2, Groupes A, B, C, D ou environnements non-dangereux seulement.



**AVERTISSEMENT  
(RISQUE  
D'EXPLOSION)**

LA SUBSTITUTION DE TOUT COMPOSANT PEUT NUIRE À LA CONFORMITÉ DE CLASSE I, DIVISION 2 (ZONE 2).



**AVERTISSEMENT  
(RISQUE  
D'EXPLOSION)**

LORSQUE DANS DES ENDROITS DANGEREUX, DÉBRANCHEZ LE CORDON D'ALIMENTATION AVANT DE REMPLACER OU DE BRANCHER DES MODULES.



**AVERTISSEMENT  
(RISQUE  
D'EXPLOSION)**

NE DÉBRANCHEZ PAS L'ÉQUIPEMENT PENDANT QUE LE CIRCUIT EST DIRECT OU À MOINS QUE L'ENVIRONNEMENT SOIT CONNU POUR ÊTRE LIBRE DE CONCENTRATIONS INFLAMMABLES.



**AVERTISSEMENT  
(RISQUE  
D'EXPLOSION)**

DANS LES ENDROITS DANGEREUX OU POTENTIELLEMENT DANGEREUX, NE PAS SÉPARER UNE PARTIE DE L'UNITÉ SOUS TENSION. SEULEMENT UTILISEZ L'APPAREIL POUR LES CONNEXIONS INTERNES.

## Section 2 LED Indicators

### Overview

All these industrial Ethernet switches have 1 or 2 communication LEDs for each port and a power LED. The managed models also have an “OK” output LED, a status LED and dual power LEDs. Refer to the sample pictures below for the location of these LEDs.

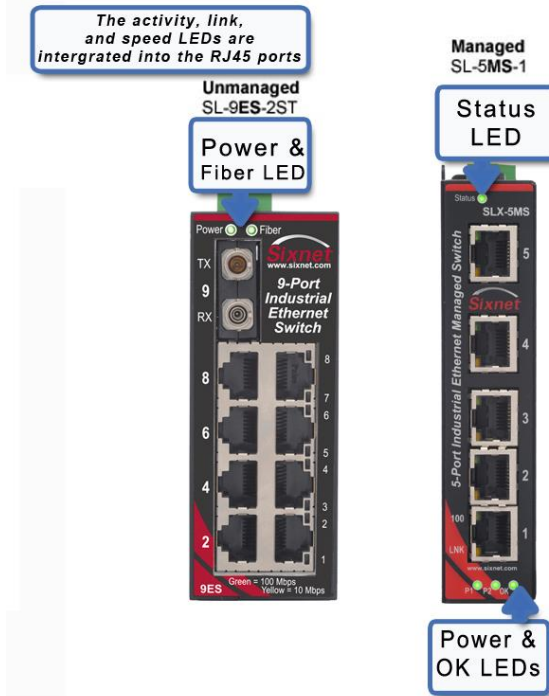

Typical LED Location (varies with model)

### Status LED

**Managed Models Only:** The Status LED indicates the overall health of the switch. It is normally ON solid indicating that no internal CPU or software problems are detected. It will flash when loading firmware and briefly on power up or reset. Otherwise, if it is OFF or flashing for an extended period of time then a problem is detected. In this case, please contact Red Lion for support.

### Power LED

On unmanaged models there is typically one power LED that is ON if either power input (P1 or P2) has power applied to it. On the managed models (and some unmanaged models) there are two Power LEDs that indicate if there is power applied to the respective input.

### ACT / LNK LED

This is the **Yellow** LED on models with two LEDs per RJ45 port.

<b>ON (yellow) (not flashing)</b>	Indicates that there <u>is</u> a proper Ethernet connection (Link) between the port and another Ethernet device, but no communications activity is detected.
<b>ON (yellow) (flashing)</b>	Indicates that there <u>is</u> a proper Ethernet connection (Link) between the port and another Ethernet device, and that there is communications activity.
<b>OFF</b>	Indicates that there <u>is not</u> a proper Ethernet connection (Link) between the port and another Ethernet device. Make sure the cable has been plugged securely into the ports at both ends.

### Speed 10/100 LED

This is the **Green** LED on models with two LEDs per RJ45 port.

<b>ON (green)</b>	A 100 Mbps (100BaseT) connection is detected.
-------------------	-----------------------------------------------

**ACT / LNK / Speed LED**

<b>OFF</b>	A 10 Mbps (10BaseT) connection is detected.
------------	---------------------------------------------

This is a bi-color (**green and yellow or orange**) LED on models with one LED per RJ45 port.

<b>ON Solid (not flashing)</b>	Indicates that there <u>is</u> a proper Ethernet connection (Link) between the port and another Ethernet device, but no communications activity is detected.
<b>Flashing</b>	Indicates that there <u>is</u> a proper Ethernet connection (Link) between the port and another Ethernet device, and that there is communications activity.
<b>Green</b>	On 10/100 ports, a 100 Mbps connection is detected. On 10/100/1000 ports, a 1000 Mbps connection is detected.
<b>Yellow or Orange</b>	On 10/100 ports, a 10 Mbps connection is detected. ON 10/100/100 ports, a 10 or 1000 Mbps connection is detected.
<b>OFF</b>	Indicates that there <u>is not</u> a proper Ethernet connection (Link) between the port and another Ethernet device. Make sure the cable has been plugged securely into the ports at both ends.

**PoE LED**

<b>ON</b>	A valid Powered Device (PD) is detected and the switch is sourcing power on this port.
<b>OFF</b>	No valid Powered Device (PD) is detected and no power is sourced.
<b>Periodically Blinks ON</b>	No valid Powered Device (PD) is detected or the connected device is drawing too little current (<10 mA) so no power is being sourced. Once the connected device is loaded and draws more than 10 or 15 mA then power will be sourced.
<b>Error Code Blink</b>	If you see the same sequence of blinks repeatedly, then contact Red Lion for more information.

**OK LED**

**Managed Models and Some Unmanaged Models:** This LED indicates the status of the power inputs. There is an output screw terminal that can be connected as shown in the wiring diagram. The output voltage from the screw terminal marked 'OK' will be the same as the applied switch input voltage. The output will be ON when both the P1 and P2 terminals have power applied to them. It will be OFF if either input does not have power or the switch software is not running.

## Section 3 Installation

### Overview

These industrial Ethernet switches can be snapped onto a standard DIN rail (EN50022) or screwed directly to a flat panel. Refer to the mechanical drawings below to properly mount your switch.

**Note:** Make sure to allow enough room to route your Ethernet copper or fiber optic cables.

### SLX-#ES models in Lexan case:

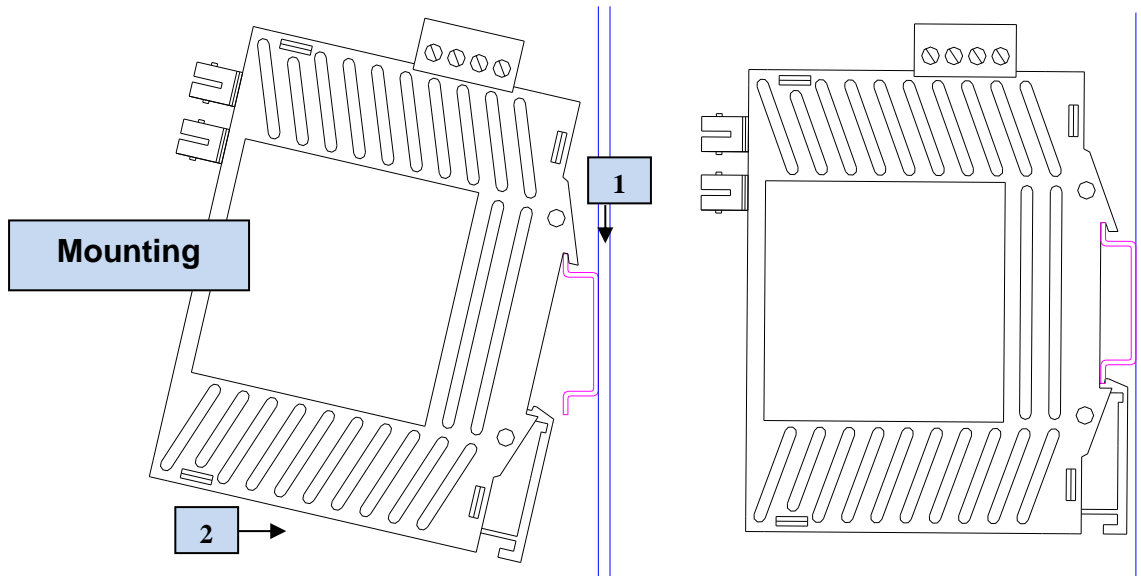

#### Recommended DIN rail mounting steps:

1. Hook the top back of the unit over the DIN rail.
2. Push the bottom of the unit towards the DIN rail until it snaps into place.

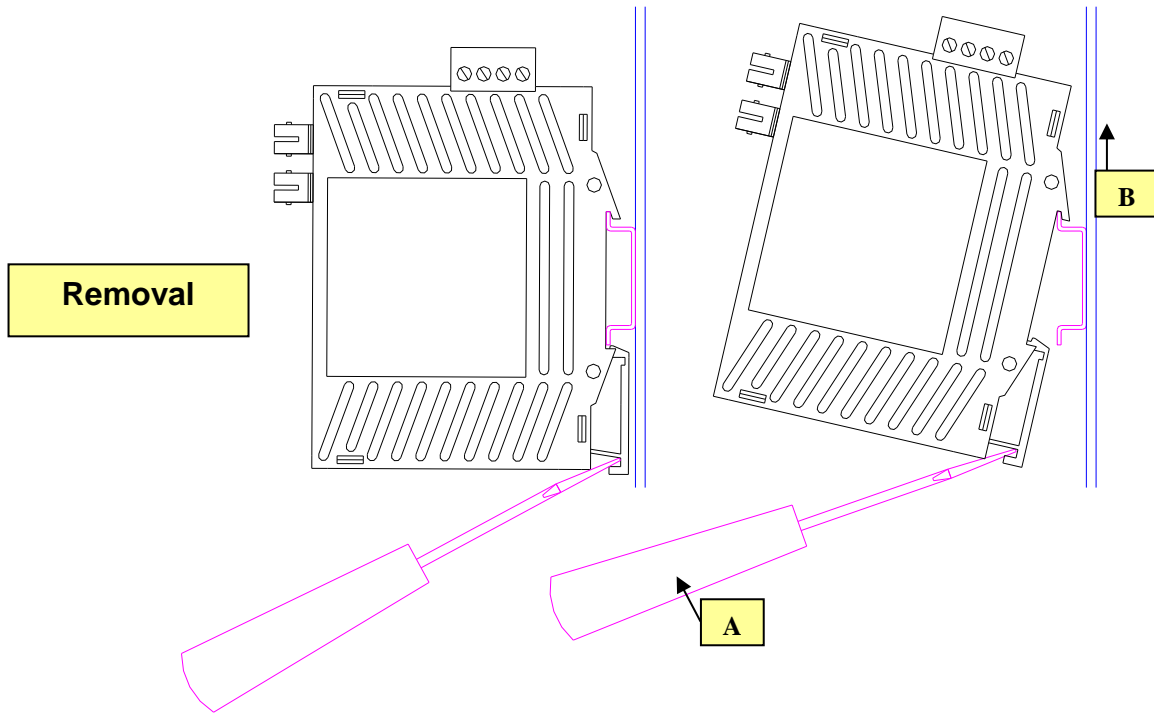

**Recommended DIN rail removal steps:**

- A. Insert screwdriver into DIN clip and pry until the bottom of the unit releases from the DIN rail.
- B. Unhook the top of the unit and remove it from the DIN rail.

**SLX-#ES models in metal case:**

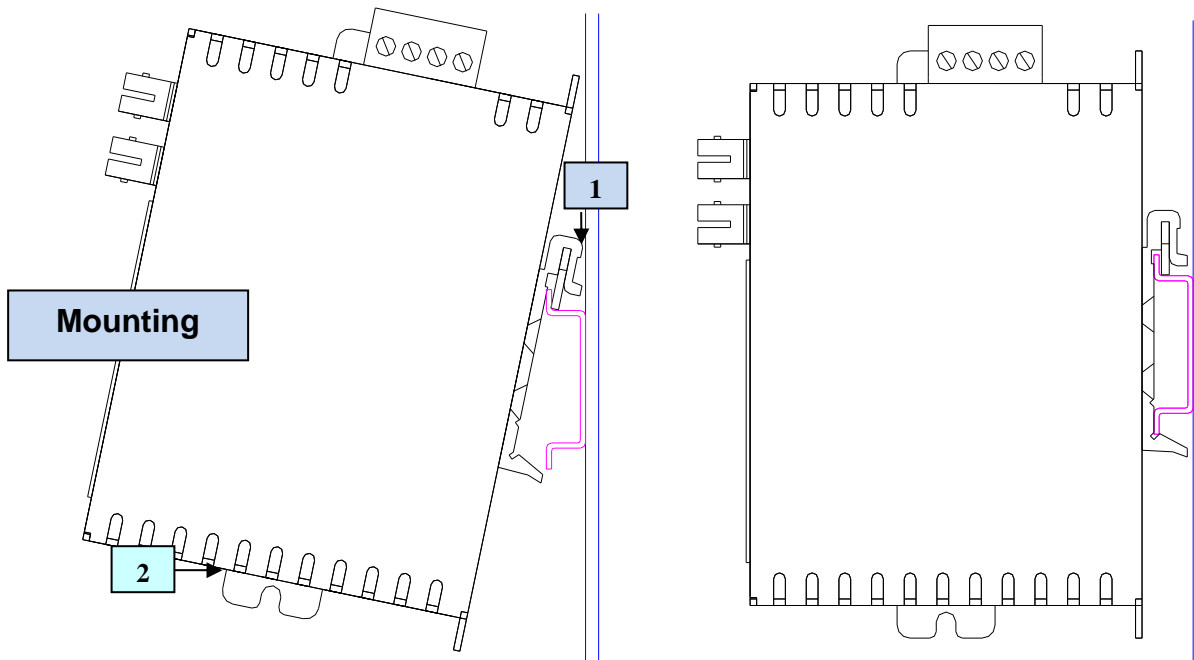

**Recommended DIN rail mounting steps:**

- 1. Hook the top back of the DIN rail clip on the unit over the DIN rail.
- 2. Push the bottom of the unit towards the DIN rail until it snaps into place.

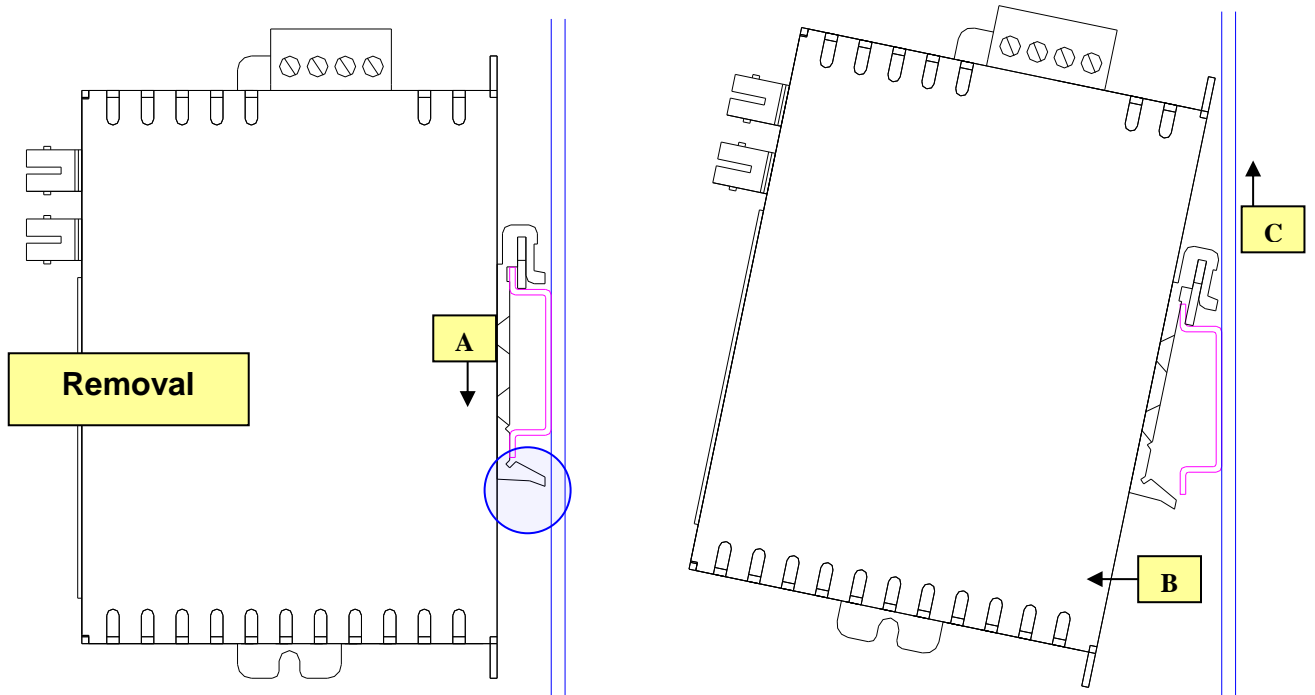

**Recommended DIN rail removal steps:**

- A. Push the whole unit down to free the bottom of the DIN rail clip. See blue circle area.
- B. Pull the bottom of the unit away from the DIN rail.
- C. Unhook the top of unit and remove it from the DIN rail.

**SLX-#MS models in metal case with plastic DIN rail clip (older models):**

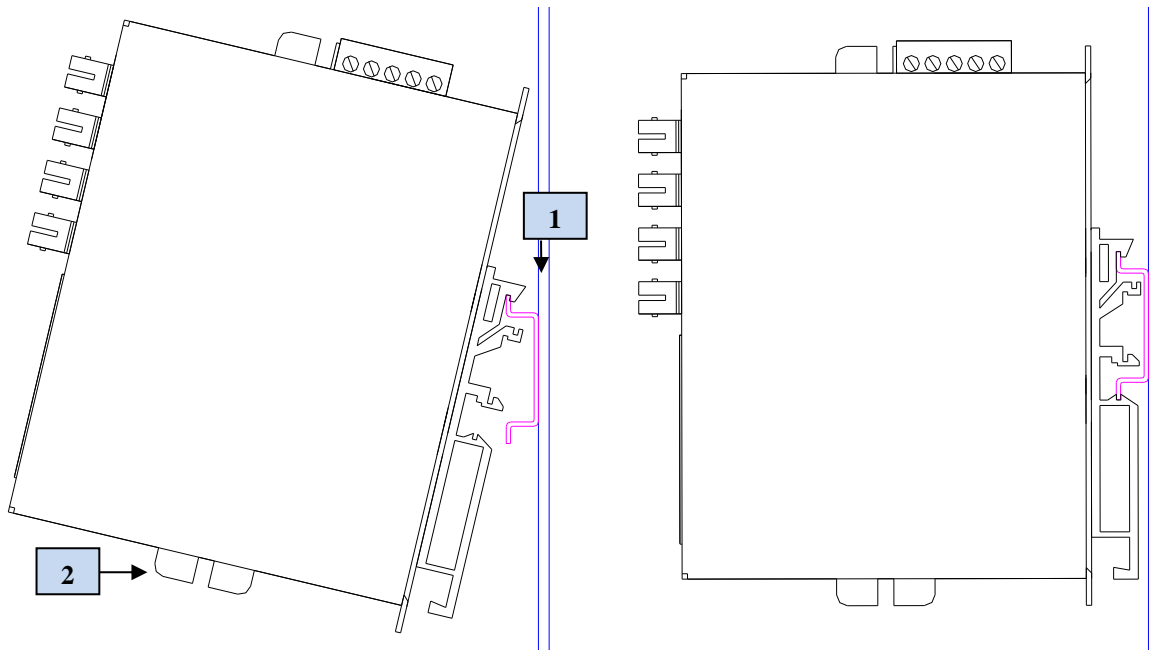

**Recommended DIN rail mounting steps:**

- 1. Hook the top back of the unit over the DIN rail.
- 2. Push the bottom of the unit towards the DIN rail until it snaps into place.

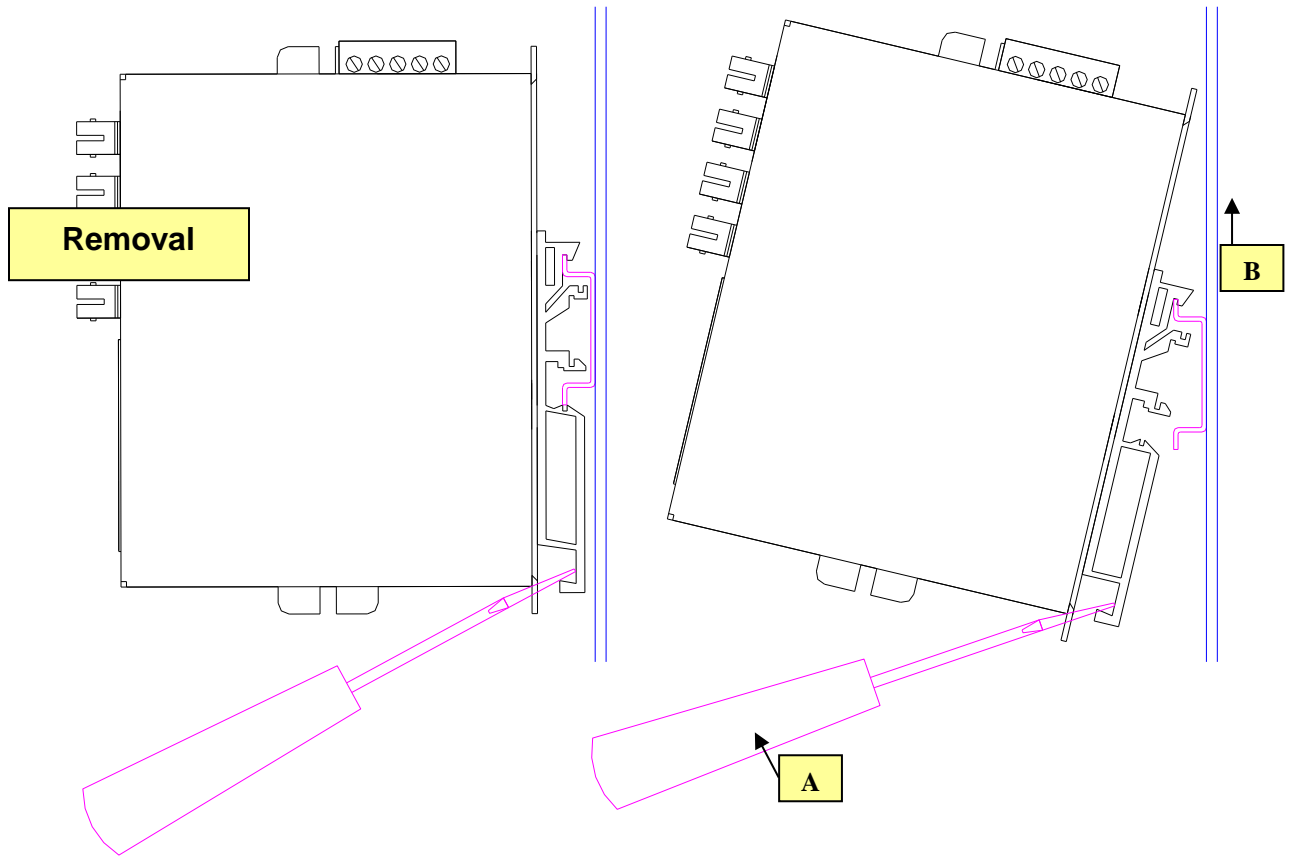

**Recommended DIN rail removal steps:**

- A. Insert screwdriver into DIN clip and pry until the bottom of the unit releases from the DIN rail.
- B. Unhook the top of the DIN clip and remove the unit from DIN rail.



**SLX-#MS and -#MG models in metal case with metal DIN rail clip:**

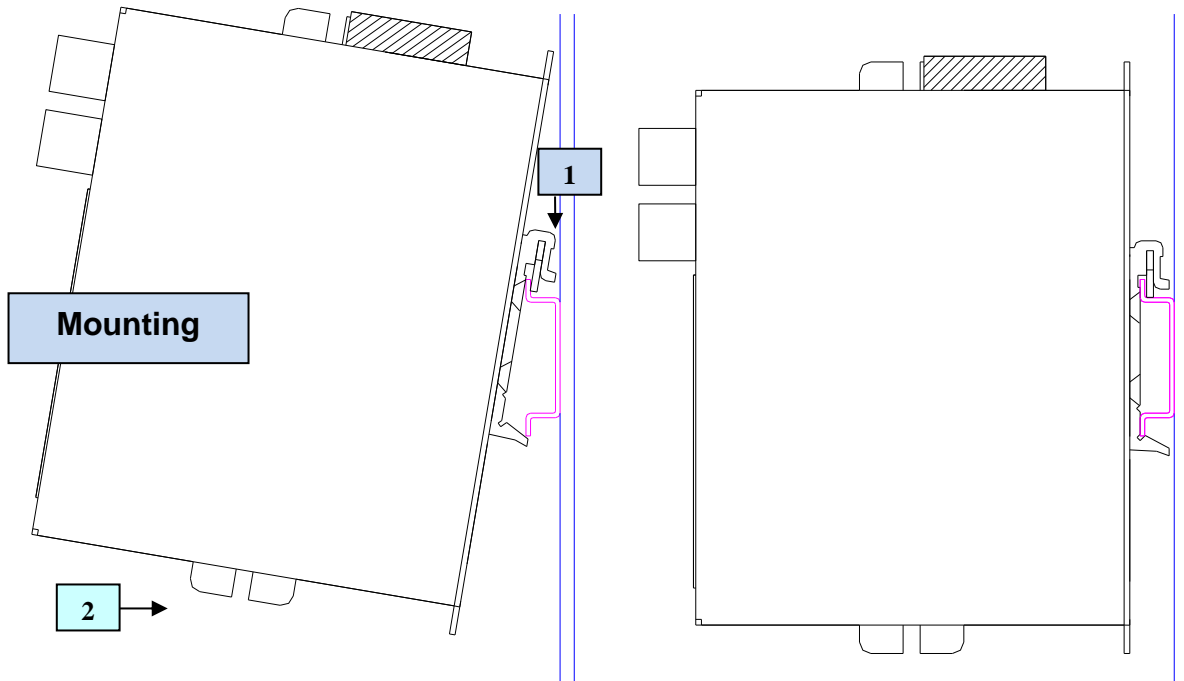

**Recommended DIN rail mounting steps:**

1. Hook the top back of the DIN rail clip on the unit over the DIN rail.
2. Push the bottom of the unit towards the DIN rail until it snaps into place.

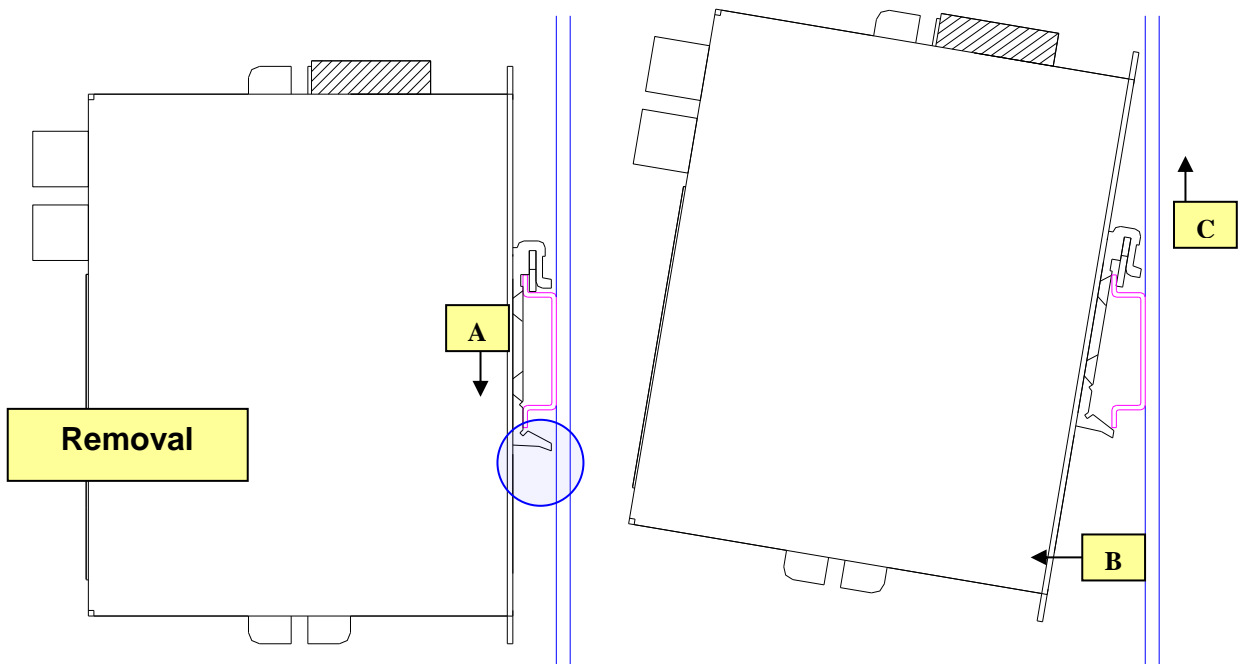

**Recommended DIN rail removal steps:**

- A. Push the whole unit down to free the bottom of the DIN rail clip. See blue circle area.
- B. Pull the bottom of the unit away from the DIN rail.
- C. Unhook the top of unit and remove it from the DIN rail.

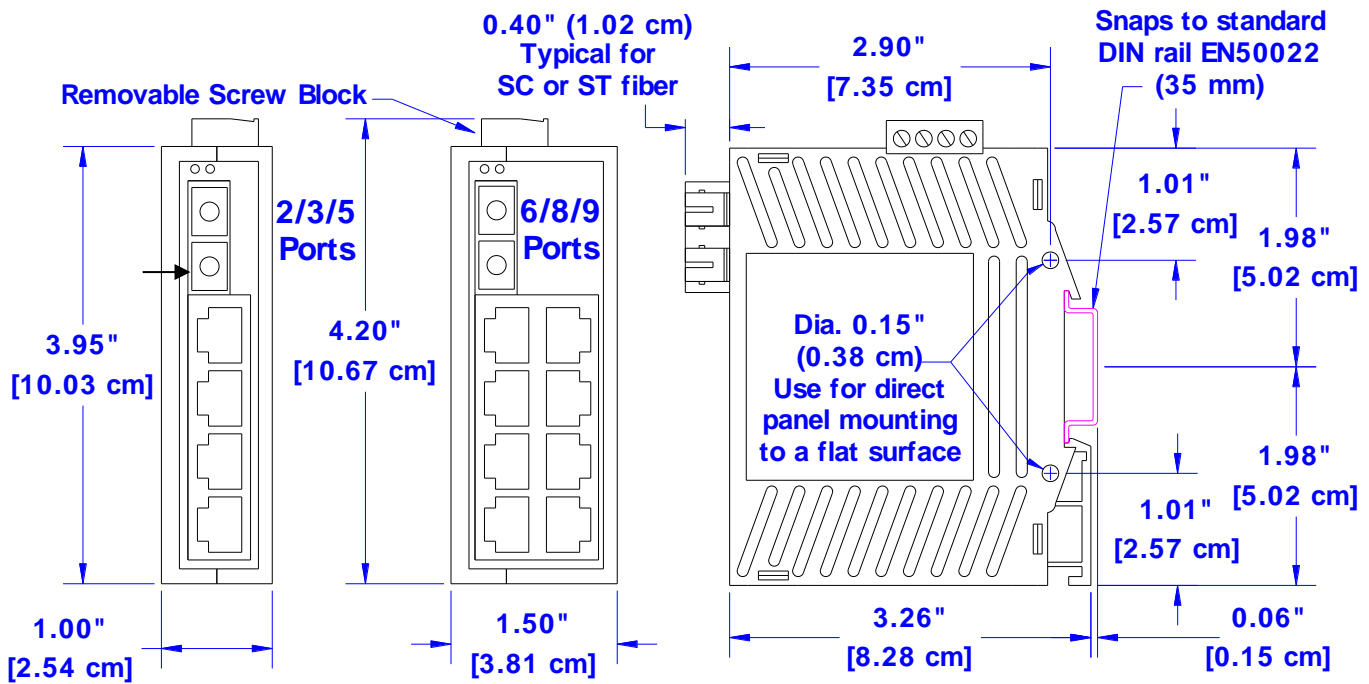

**Mechanical Dimensions for SL-2/3/5/6/8/9ES-1/2/3 in Lexan Packaging**

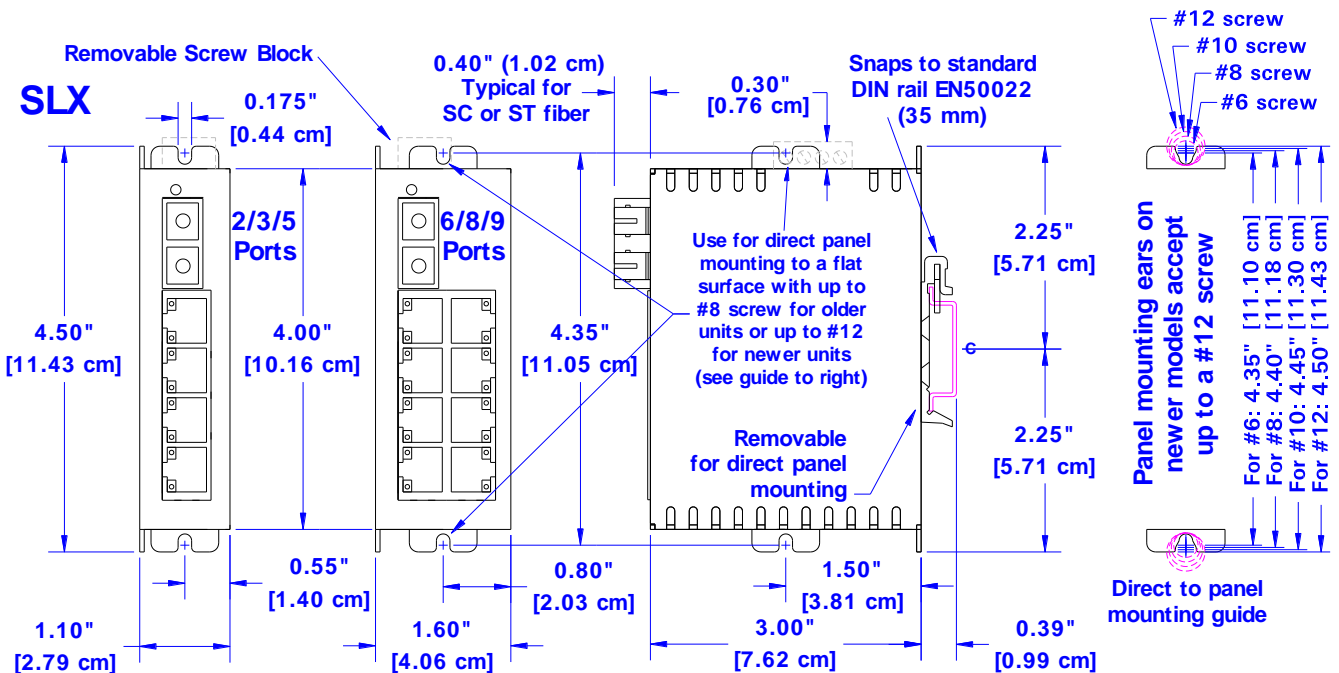

**Mechanical Dimensions for SLX-3/5/6/8/9ES-1/2/3 in Metal Packaging**

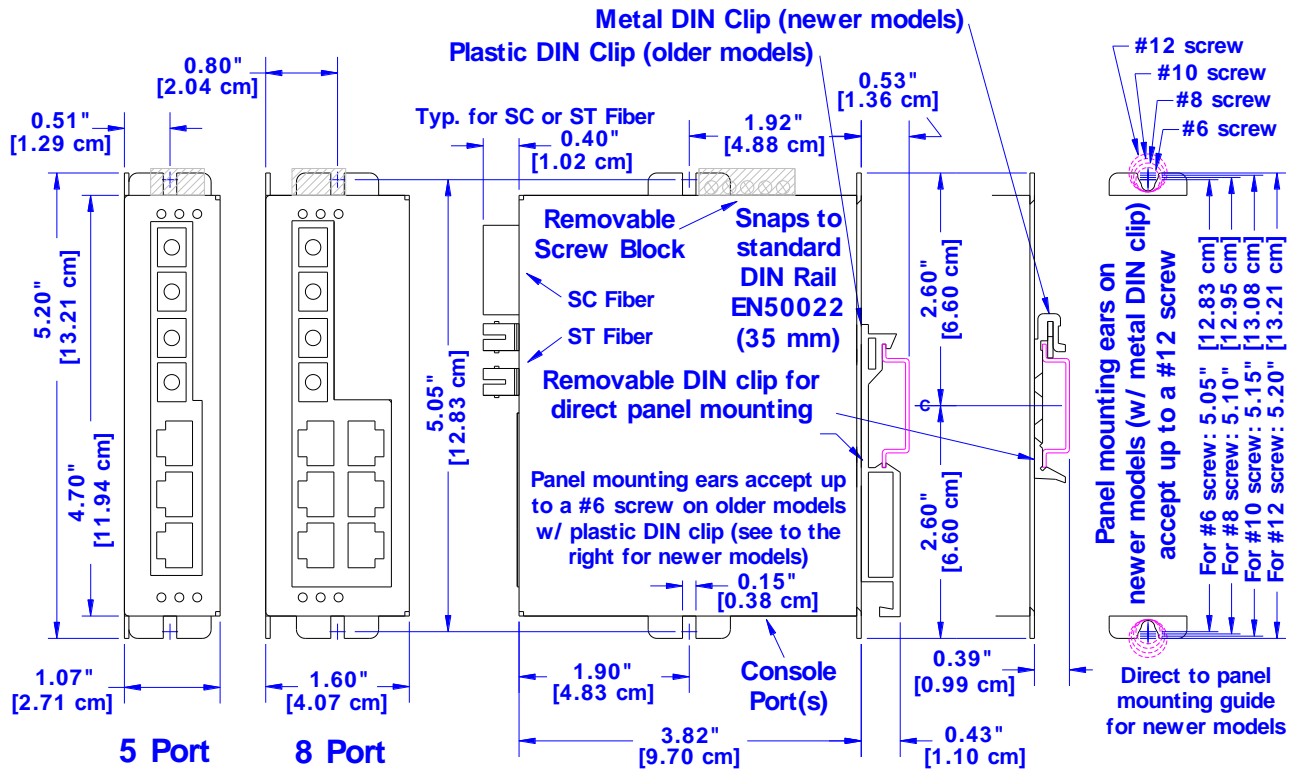

**Mechanical Dimensions for SLX-5/8MS-1/4/5 with up to 2 Fiber Ports**

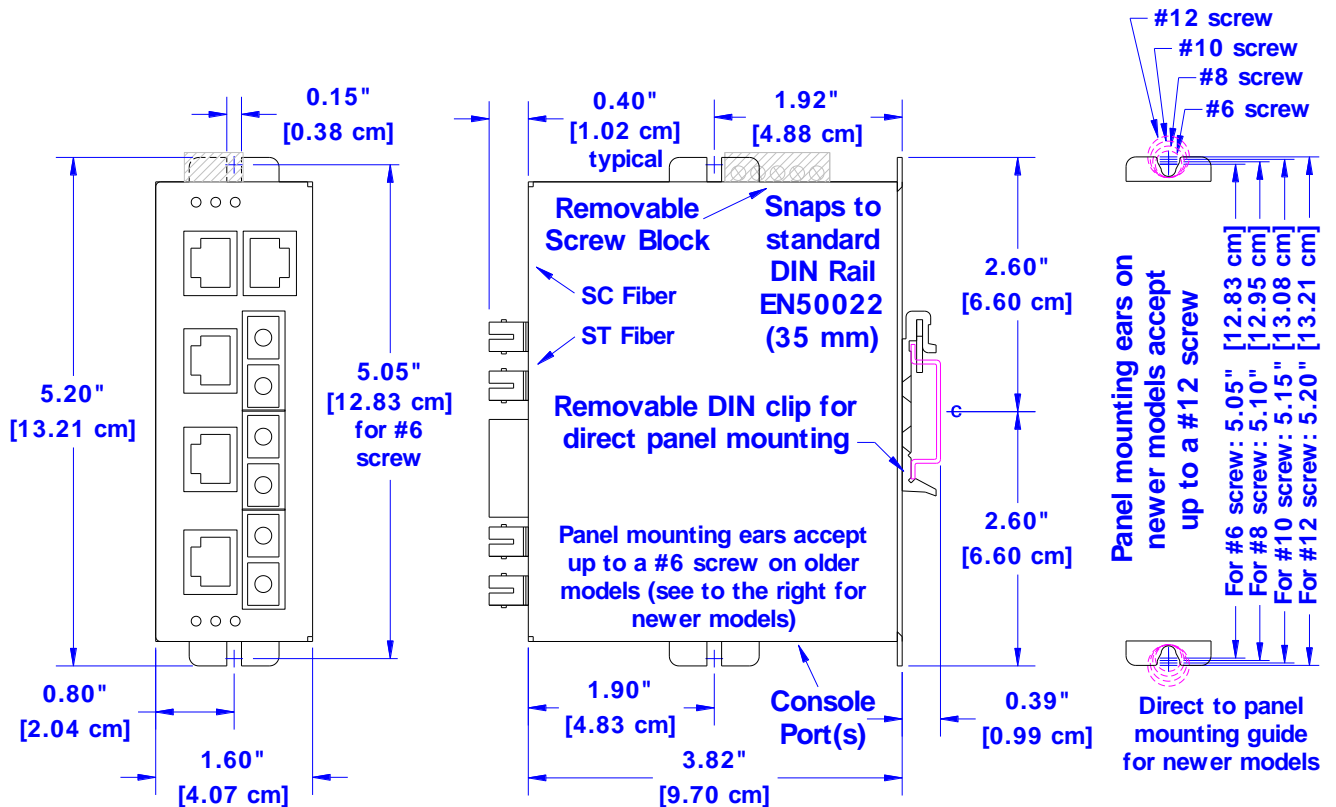

**Mechanical Dimensions for SL/SLX-8ES-6/7 with 3 Fiber Ports**

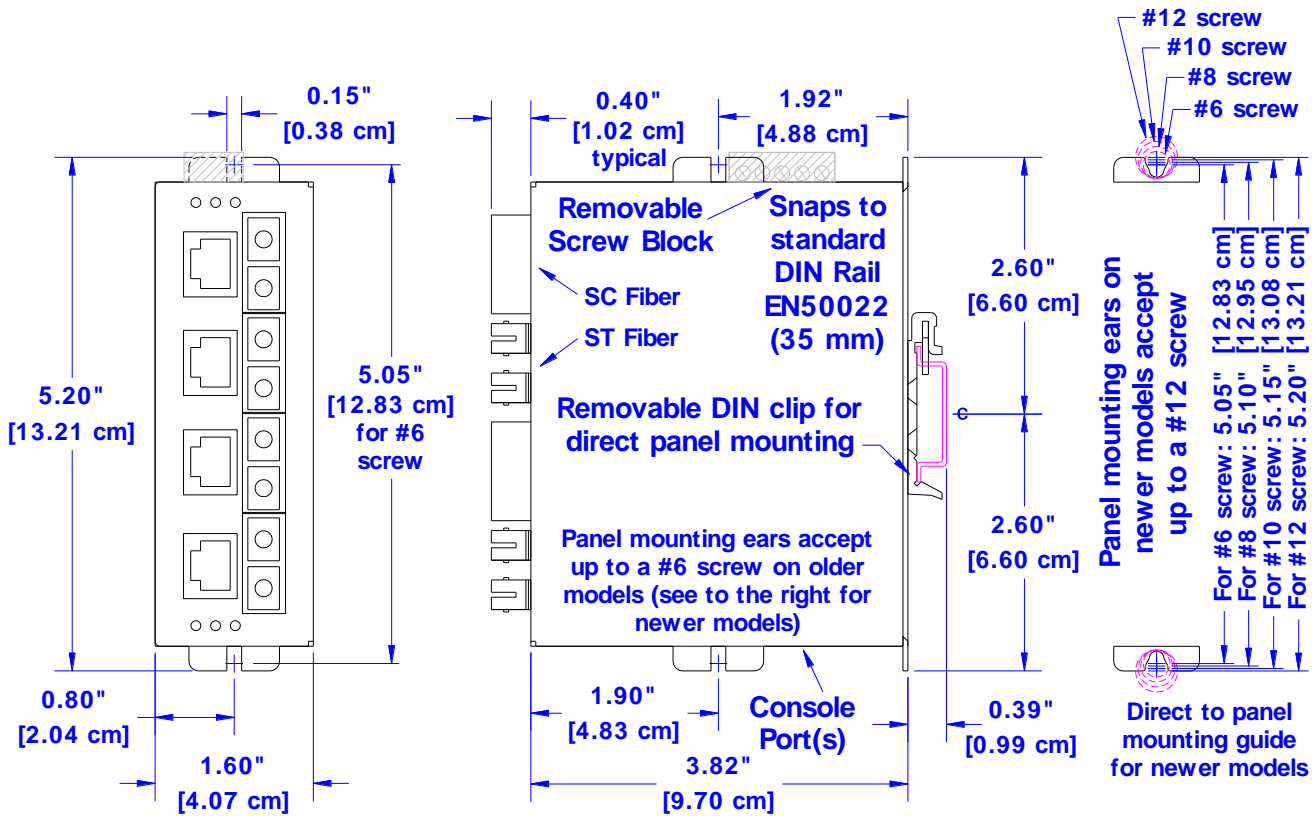

**Mechanical Dimensions for SLX-8MS-8/9 with 4 Fiber Ports**

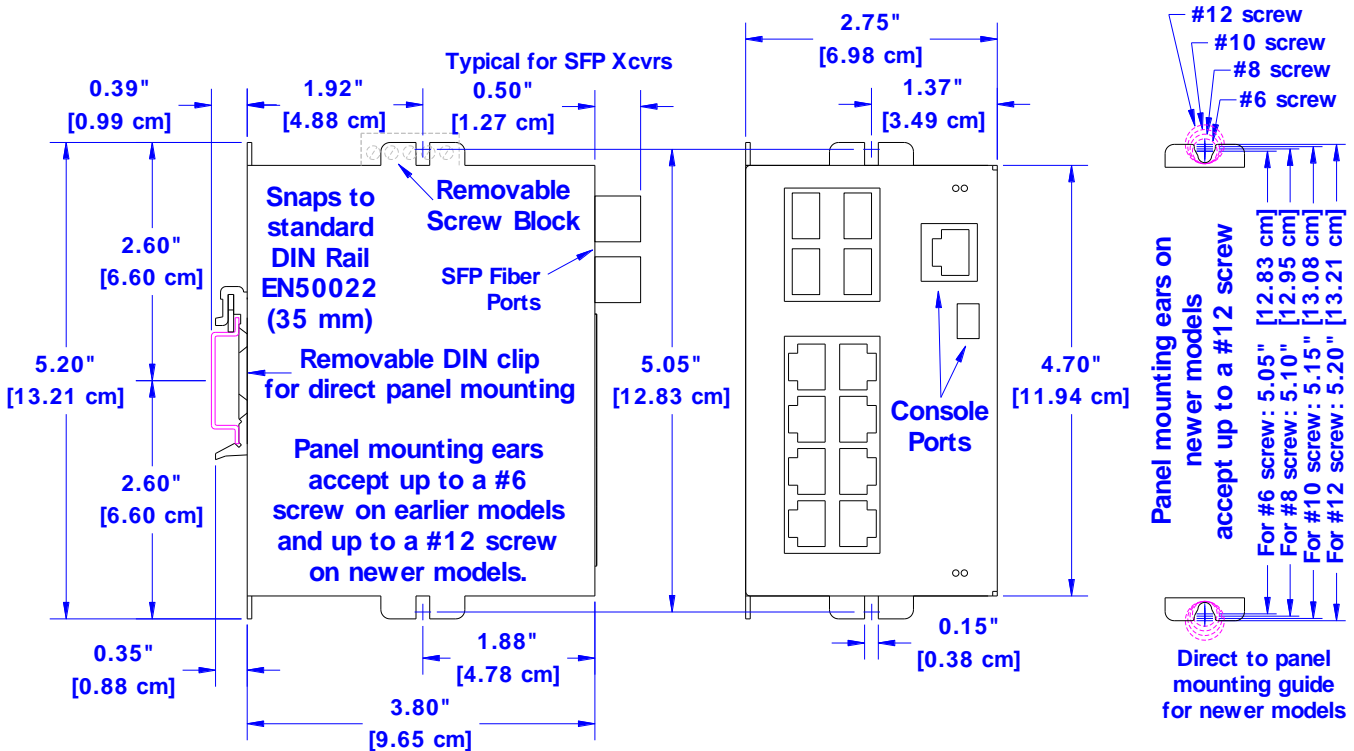

**Mechanical Dimensions for SLX-8MG with 8 Gigabit Ports**

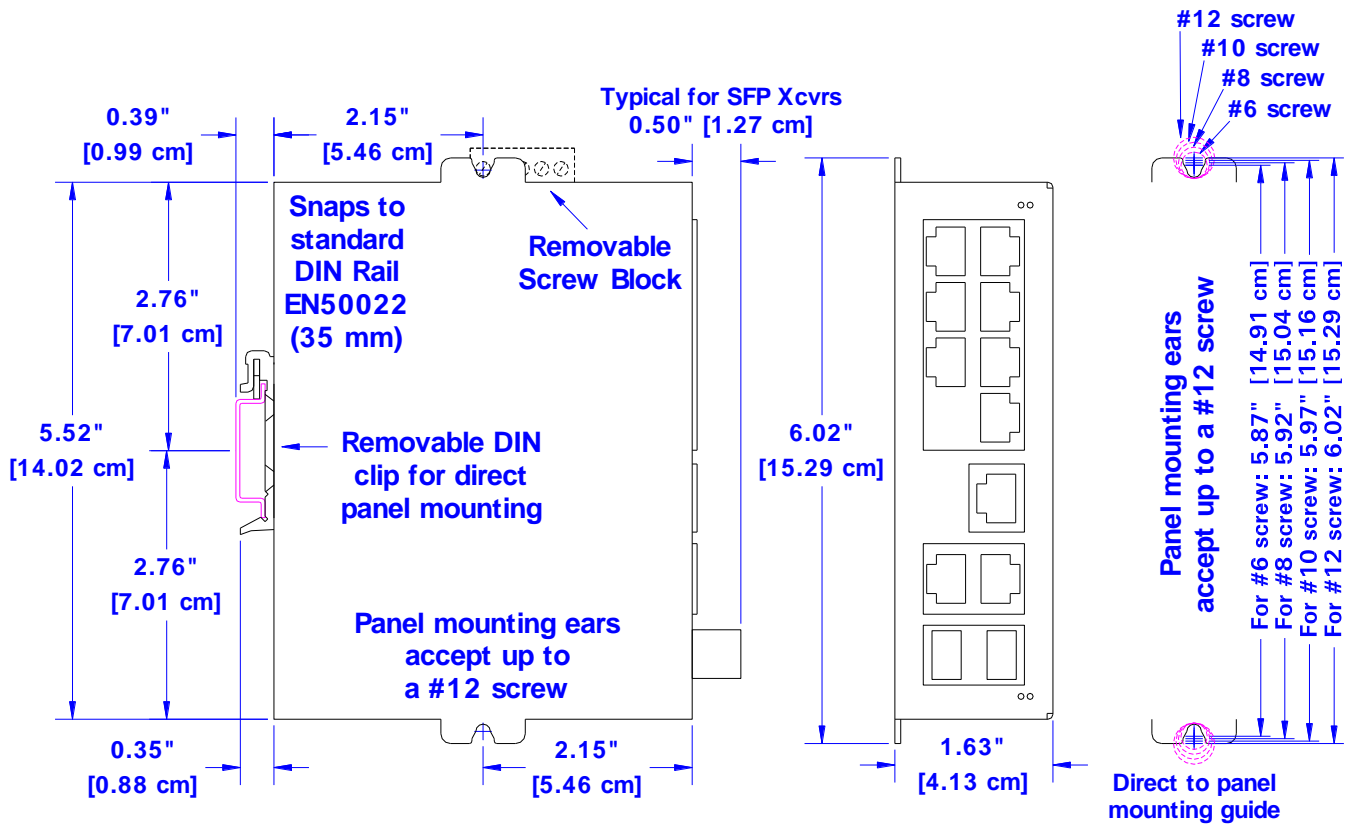

**Mechanical Dimensions for SLX-10MG-1**

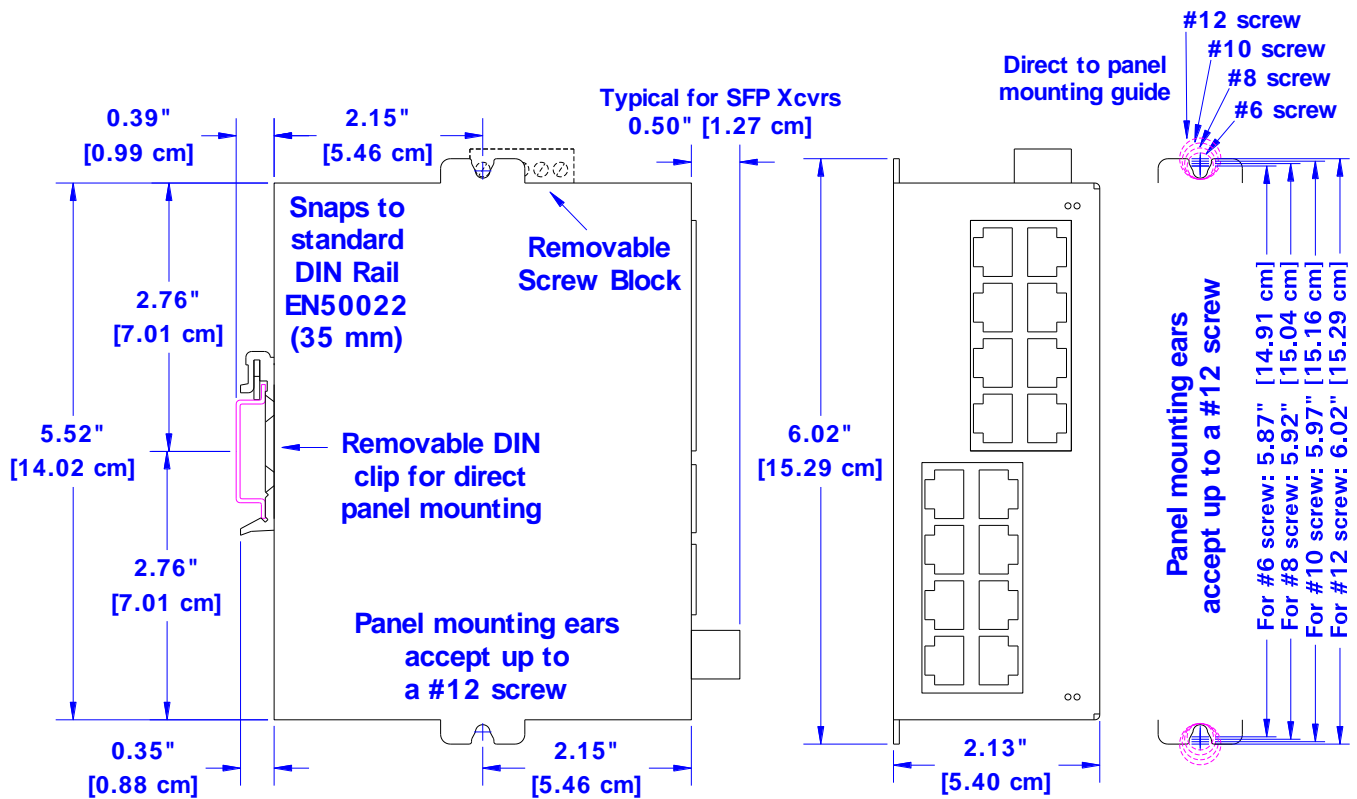

**Mechanical Dimensions for SLX-16MS-1**

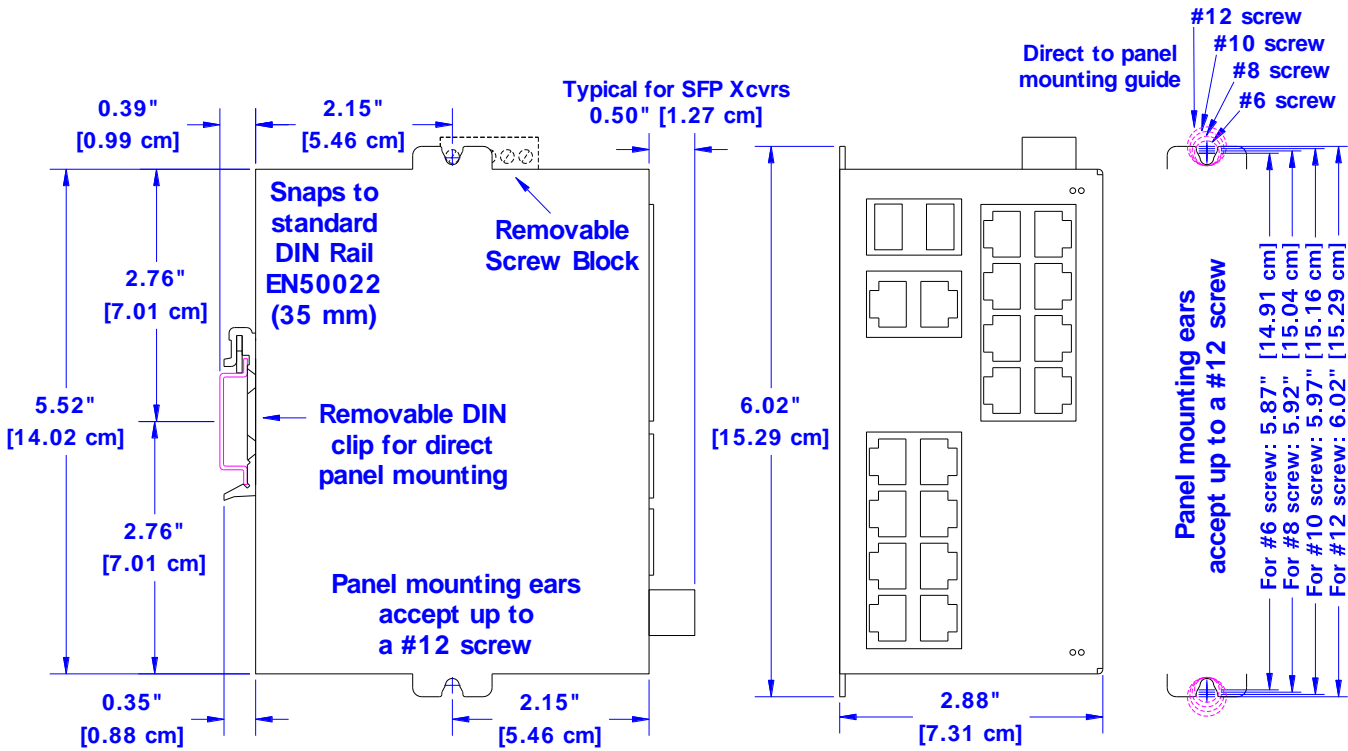

**Mechanical Dimensions for SLX-18MG-1**

# SLX-3EG-1 SFP

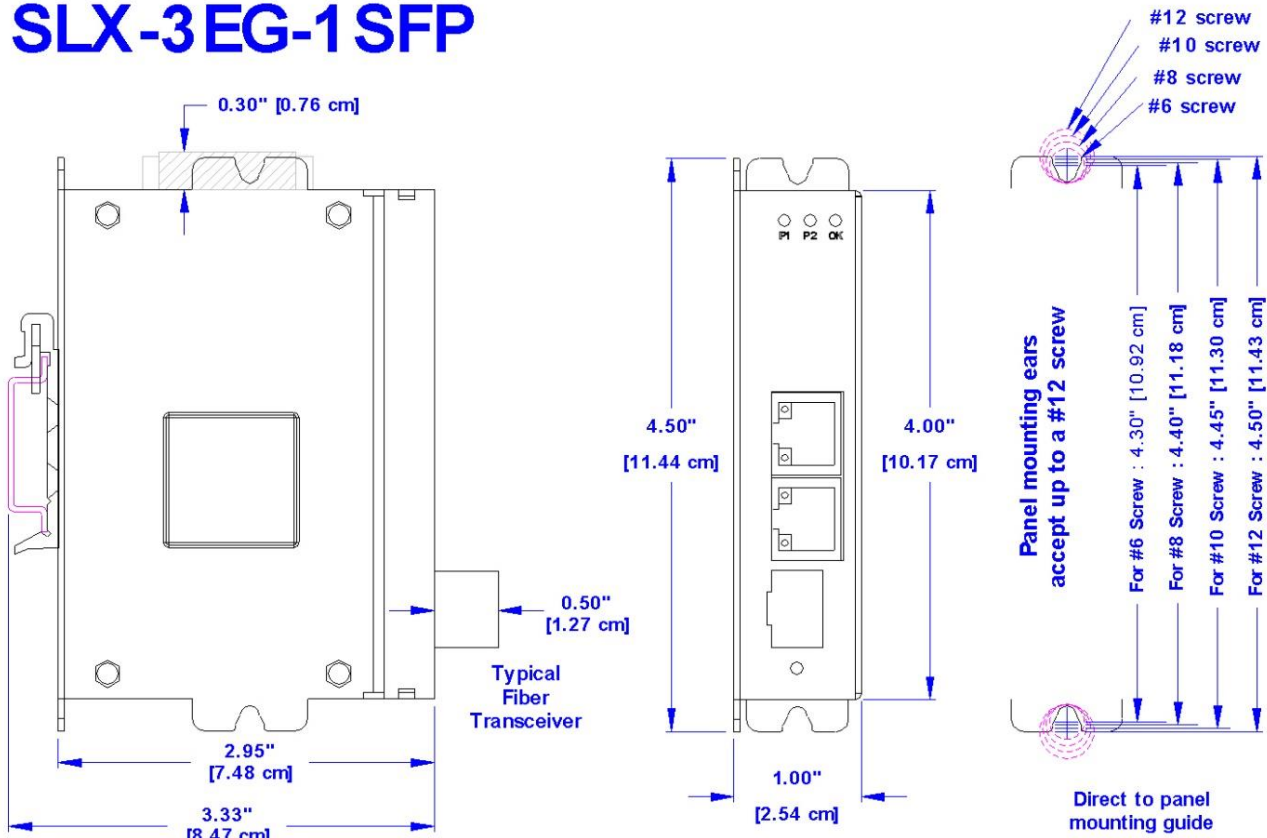

**Mechanical Dimensions for SLX-3EG-1SFP**

## SLX-5EG-2SFP

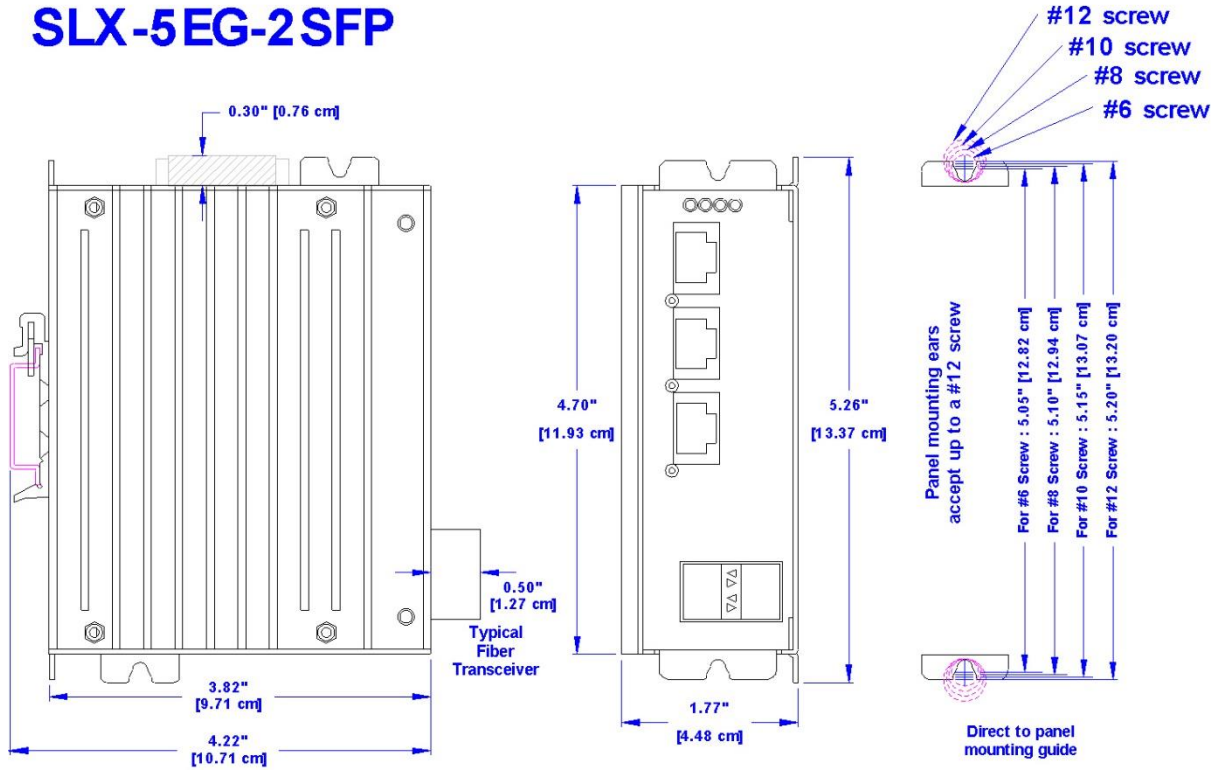

**Mechanical Dimensions for SLX-5EG-2SFP**

## SLX-5EG-1

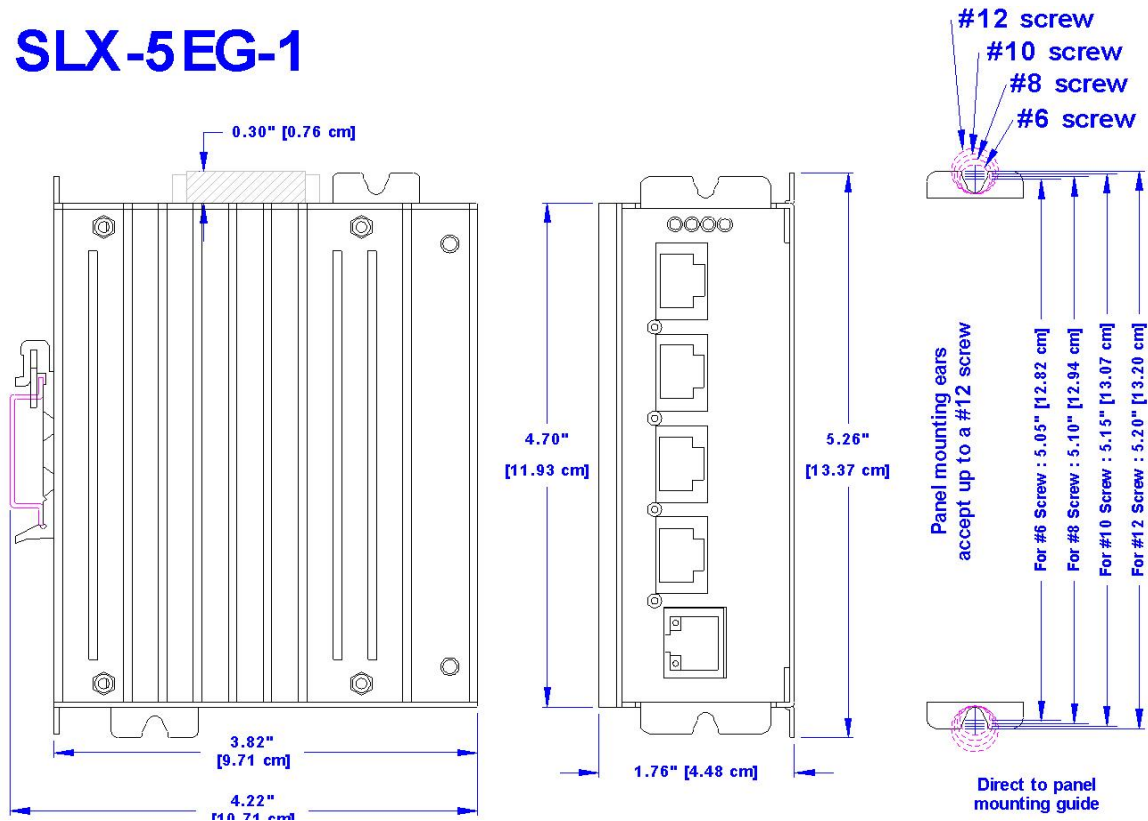

**Mechanical Dimensions for SLX-5EG-1**



The metal packaged models allow you to choose the mounting method that best fits your requirements. (Note: Not all methods are available on all models. Refer to the mechanical diagrams for details.)

**Vertical snap-on DIN rail mounting for quickest installation and optimal utilization of your rail space.**

**Vertical screw-to-panel mounting for better shock and vibration resistance.**

**Flat screw-to-panel mounting for low profile orientation in shallow boxes plus best shock and vibration resistance.**

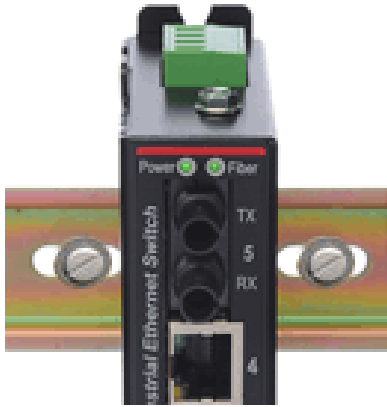

### Overview of Optional Mounting Methods

#### Important Notes about Thermal Performance:

The Slim Lines switches with metal cases use an innovative technique to remove excess heat from the product and its components. This technique effectively utilizes the heavy-gauge all-aluminum case as a large heat-sink. Therefore, you may notice the case becoming warm during operation (especially with large loads such as all ports linked and active). This is normal operation. For best performance it is recommended that a DIN rail spacer (such as an end clamp) be used between the switch and adjacent devices. This will leave an air gap for best heat dissipation off the case.

For best thermal performance when direct panel mounting to a metal surface, you may use a thermal compound or pad between the mounting face and the mounting surface. This will reduce any air gaps and optimize the transfer of heat from the case to the mounting surface.

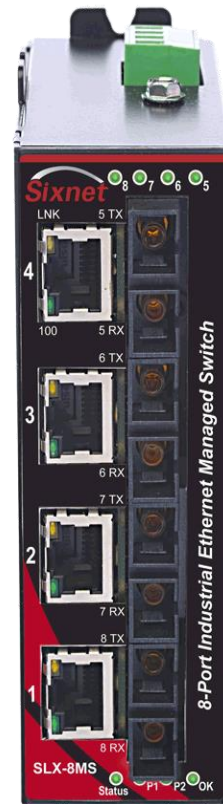



## Section 4 Power Wiring

### Overview

These industrial Ethernet switches can be powered from the same DC source that is used to power your other devices. A voltage in the range of 10 to 30 VDC needs to be applied between the P1 (plus) terminal and the Minus terminal as shown in the diagrams on the next page. The chassis screw terminal should be tied to panel or chassis ground. To reduce down time resulting from power loss, these industrial Ethernet switches can optionally be powered redundantly with a second power supply as shown in the diagrams.

The managed models also have an “OK” output that can be tied to a PLC input or other device to indicate when there is a power loss. When ON, this output will source the same voltage that is applied to the switches power terminals. See the wiring diagrams on the next page.

Models with PoE accepts power in the range of 12 to 48 VDC and can source 48 VDC power to four PoE devices. For PoE sourcing (PSE) operation, the power must be in the range of 45 to 50 VDC. Otherwise, the switch will function properly as an industrial Ethernet switch but will not source any PoE power. For PoE operation, make sure your 48 VDC supply is rated for at least 16 Watts per PoE channel being sourced, plus some overhead for the switch. It is recommended that a supply with 75 Watts or more of power be used. PoE switches support dual power inputs allowing you to connect a backup power source. The backup power should have the same voltage as the primary power.

The PoE ports when sourcing power will put out 48 VDC\* (see note below) over the signal pair of the RJ45 connection:

- V+ on RX lines 1 and 2
- V- on TX lines 3 and 6
- Lines 4, 5, 7 and 8 are unused

**\* Note:** When the supply voltage is 45 to 47 VDC then the power output for the PoE will be the same as the supply voltage. For example, if the supply voltage is 45 VDC then the PoE output will also be 45 VDC. If the supply voltage is 48 to 50 VDC then the PoE output will be regulated at 48 VDC.

### Screw Torque

When tightening the screws be careful to tighten to a max. torque of 5 in/lb (0.57 Nm).

### WIRING WARNINGS



BEFORE PERFORMING ANY WIRING TO THESE SWITCHES MAKE SURE ...

- THE AREA IS CURRENTLY NONHAZARDOUS (ESPECIALLY WHEN WORKING IN CLASS I, DIV 2 OR ZONE 2 HAZARDOUS LOCATIONS)
- TO TURN OFF THE POWER TO THE SWITCH
- TO UNPLUG THE SCREW TERMINAL BLOCK (This is especially important on the units that have a metal case as shown below. Connecting or disconnecting wires to the screw block when it is in place and the power is turned on can allow the screwdriver to short the power to the case.)



To meet the requirements for UL you must do one of the following:

1. Install a 3.33 Amp maximum fuse at the input of the switch.
- OR
2. Use a Class 2 rated power supply to power the switch.

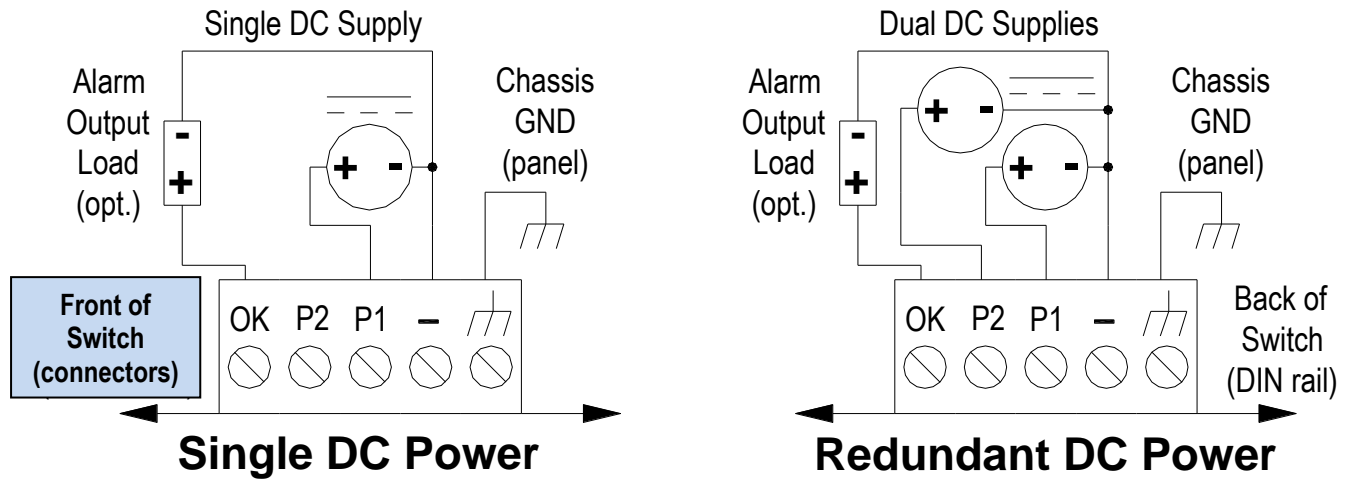

**Power & Alarm Wiring for  
SLX-5/8MS Managed Switches**

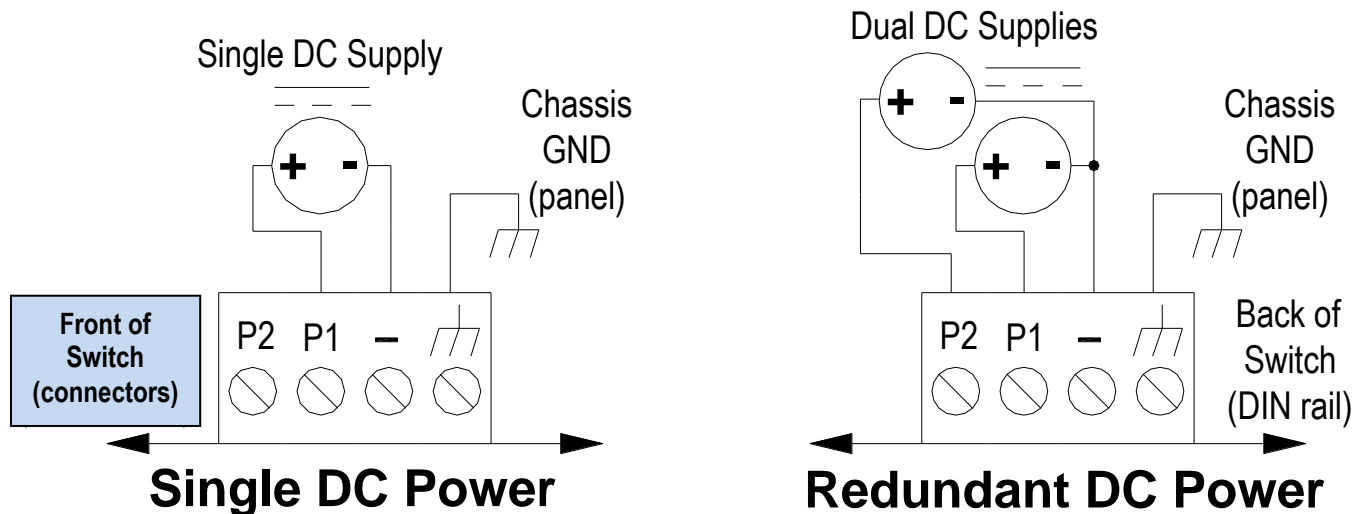

**Power Wiring for  
SL/SLX-5/8/9ES Unmanaged Switches  
and SL-2ES Media Converter**

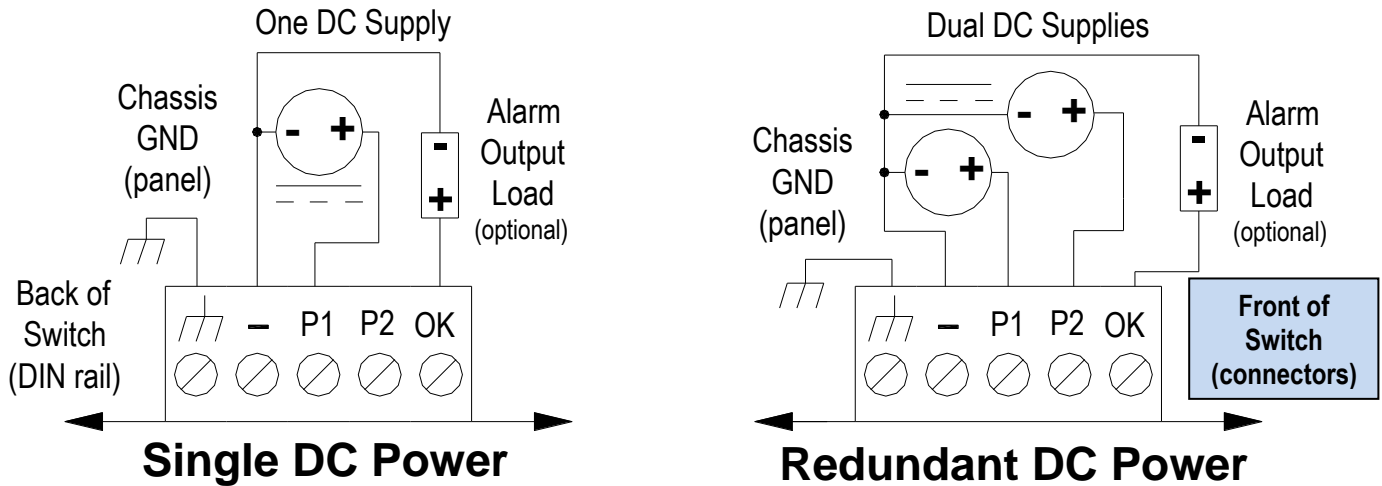

**Power & Alarm Wiring for SLX-8MG Managed Switches**

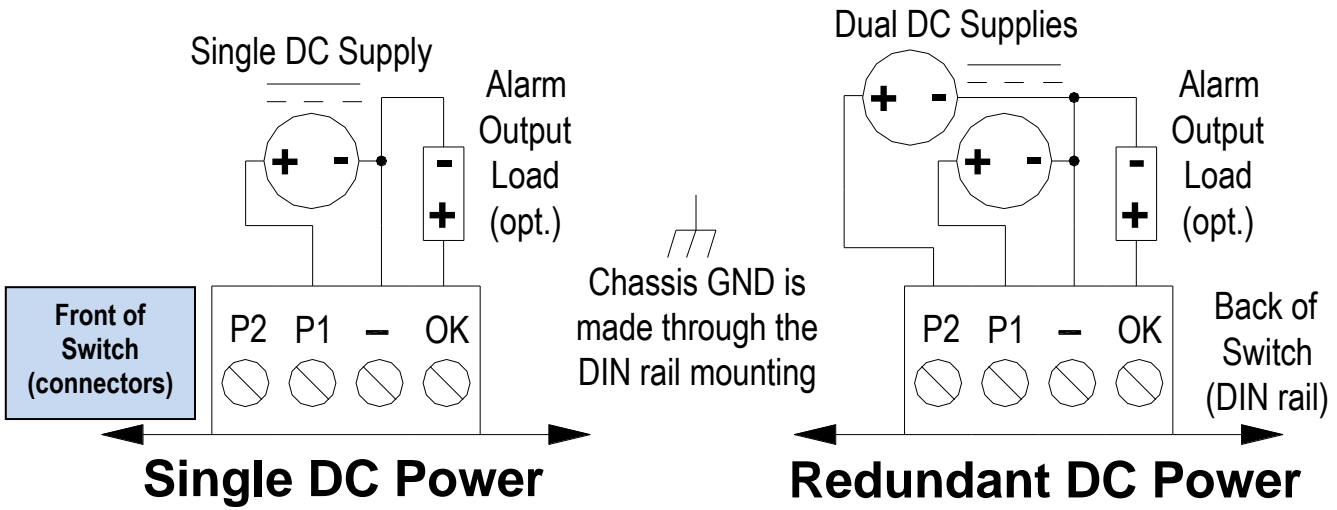

**Power and Alarm Wiring For SL/SLX-6ES Unmanaged Switches**

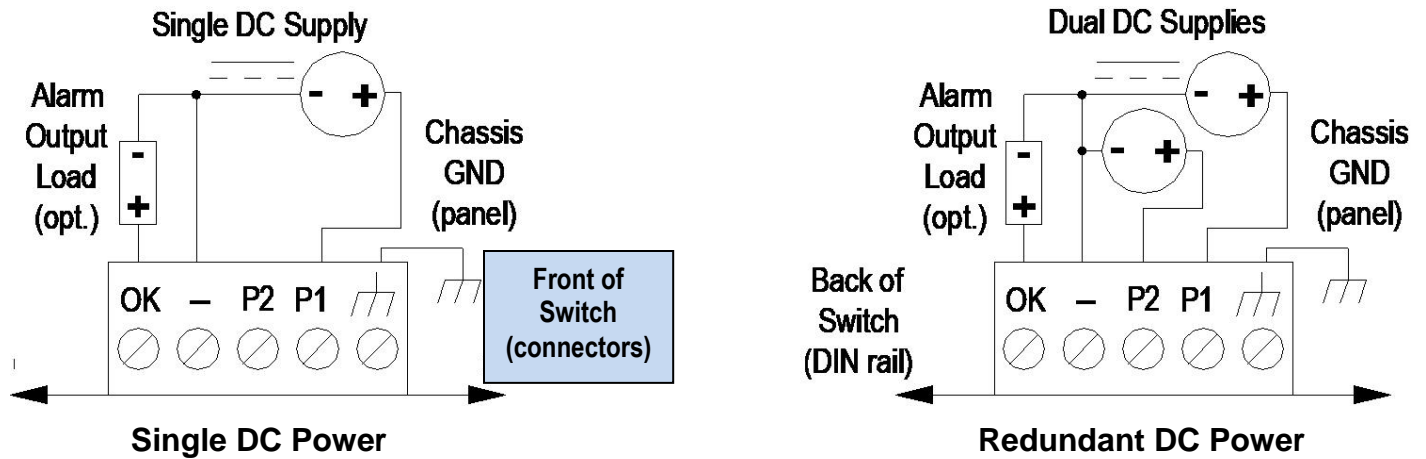

**Power and Alarm Wiring For**

**Power and Alarm Wiring for  
SLX-10/16/18-Mx Managed Switches**

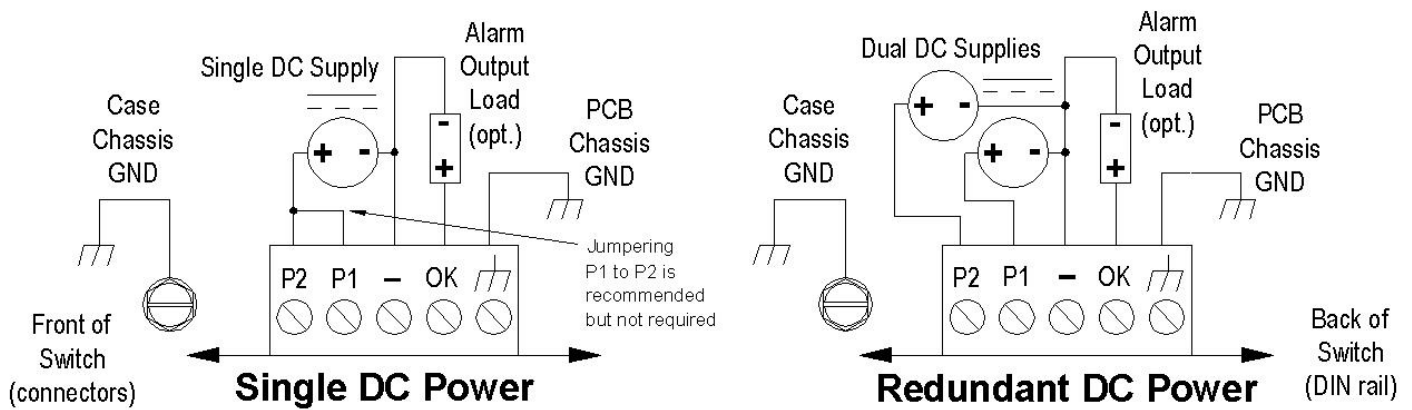

**Power and Alarm Wiring for  
SLX-3EG-1 Managed Switches**

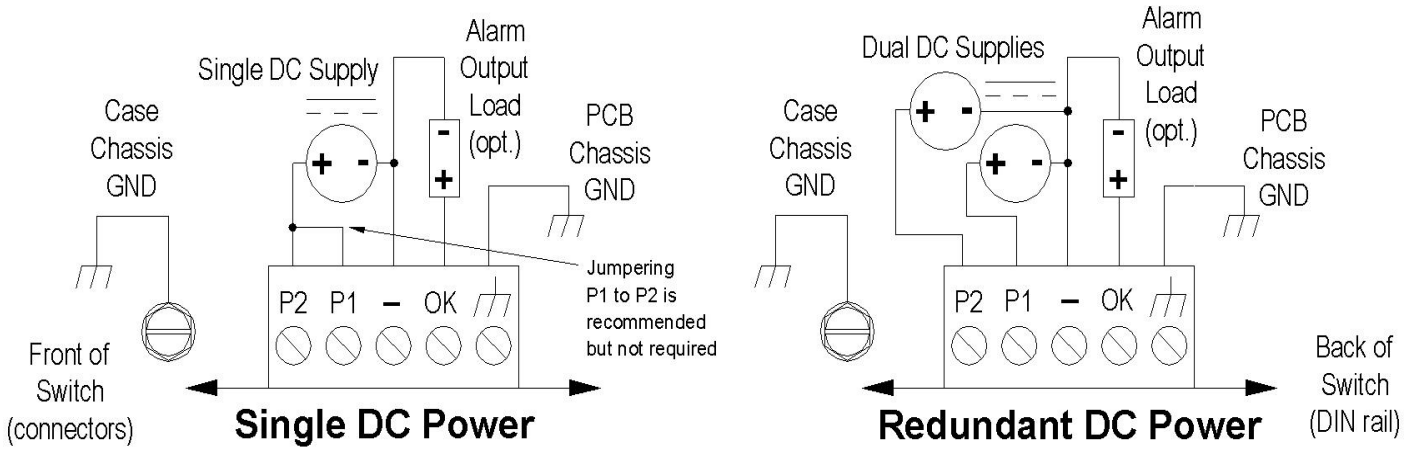

**Power and Alarm Wiring for SLX-5EG-1 Managed Switches**

## Section 5 Communication Wiring

### Overview

These industrial Ethernet switches provide connections to standard Ethernet devices such as PLCs, Ethernet I/O, industrial computers and much more. Three types of communication ports may be found on these switches: RJ45 (copper) Ethernet ports, fiber optic Ethernet ports and a serial or USB console port for management (managed models).

### RJ45 Ethernet Wiring

Use data-quality (not voice-quality) twisted pair cable rated category 5 (or better) with standard RJ45 connectors. For best performance use shielded cable. Straight through or crossover RJ45 cable can be used regardless of the device the switch is to be connected to as all the ports are capable of auto-mdi/mdix-crossover detection.

The RJ45 Ethernet port connector bodies on these products are metallic and are connected to the Chassis GND terminal. Therefore, shielded cables may be used to provide further protection. To prevent ground loops, the cable shield should be tied to the metal connector body at one end of the cable only. Electrical isolation is also provided on the Ethernet ports for increased reliability.

For Reference Only.  
Either cable wiring will work!

Straight-thru Cable Wiring	
Pin 1	Pin 1
Pin 2	Pin 2
Pin 3	Pin 3
Pin 6	Pin 6

Cross-over Cable Wiring	
Pin 1	Pin 3
Pin 2	Pin 6
Pin 3	Pin 1
Pin 6	Pin 2

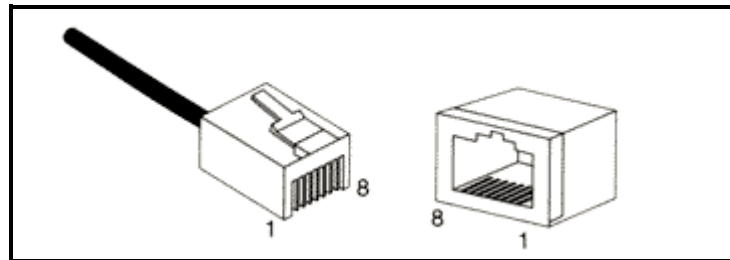

**Ethernet Plug & Connector Pin Positions**

### RJ45 Cable Distance

The maximum cable length for 10/100/1000BaseT is typically 100 meters (328 ft.).

### Ethernet Fiber Wiring Guidelines

Depending on the model these industrial Ethernet switches may have up to four fiber optic ports. All 100 Mbps fiber ports are available with dual SC or ST style connectors. They are also available with multimode, singlemode, long-haul (for connections up to 120+ km) or special-application transceivers. Refer to the technical specifications for details.

All 1000 Mbps fiber ports are provided as mini-gbic SFP (small form pluggable). These accept plug in fiber transceivers that typically have an LC style connector. They are available with multimode, singlemode, long-haul (for connections up to 80+ km) or special-application transceivers. Refer to the technical specifications for details.

For each fiber port there is a transmit (TX) and receive (RX) signal. When making your fiber optic connections, make sure that the transmit (TX) port of the switch connects to the receive (RX) port of the other device, and the receive (RX) port of the switch connects to the transmit (TX) port of the other device.

Use standard fiber optic wiring techniques (not covered by this manual) to make your connections. The corresponding ACT/LNK LED will be ON solid or flashing when you have made a proper connection.

For more fiber optic guidelines go to: [www.redlion.net](http://www.redlion.net)

See images below for typical fiber optic port placement on these switches.

Typical Fiber Ports on Unmanaged Models

Typical SC style connector on a SL-5ES-2/3SC



Typical ST style connector on a SL-5ES-2/3ST



Typical Fiber Ports on Managed Models

Typical SC style connector on a SLX-5MS-4/5SC



Typical ST style connector on a SLX-5MS-4/5ST



Typical SC style connector on a SLX-8xS-6/7/8/9SC

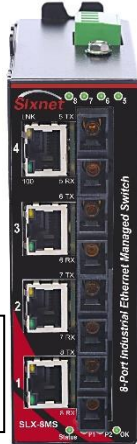

Typical Fiber Ports on an SLX-8MG

SLX-8MG with no transceivers installed



SLX-8MG with four transceivers installed





**Duplex  
Operation**

The RJ45 ports will auto-sense for Full or Half duplex operation, while the fiber ports are configured for full duplex operation. Note: Fiber devices with half duplex settings should still communicate with the switch. If otherwise then please contact Red Lion. On managed models the duplex setting is software configurable.

**Verifying  
Connectivity**

After all Ethernet and/or fiber connections are made, check the LED's corresponding to the ports that each of the devices are connected to. Ensure that for each port that is in use, the LED is on or blinking. If a port LED is off, go back and check for connectivity problems between that port and the network device connected to that particular port. In addition, the color of the LED should indicate the speed for which your device is connected at (see prior section on LEDs).

**Serial  
Console Port  
Wiring**

An optional way to configure the switch is through the RJ45 console RS232 port. Use a DB9F to RJ45F adapter along with a RJ45 male to RJ45 male straight-thru-wired patch cable to make a connection between a com port on your PC (DB9 male) and the RS232 port of the Managed Switch (RJ45 female). Contact Red Lion or your switch vendor to purchase this adapter as an accessory.

A typical DB9F to RJ45F adapter should be wired as follows:

Switch		Adapter	
RJ45F Pin #	Signal Name	Signal Name	DB9F Pin #
1	RI/DSR in	DTR out	4
2	DCD in	N/C	n/c
3	DTR out	DSR in	6
4	GND	GND	5
5	RXD in	TXD out	3
6	TXD out	RXD in	2
7	CTS in	RTS out	7
8	RTS out	CTS in	8



### USB Console Port Wiring

Newer models of these switches may also have an USB port instead of or in addition to the RS232 port. Use a standard USB cable with a mini-USB plug on one end and an A-type-USB plug on the other end. The A-type plug goes into a standard USB port on a computer. The mini-USB plug goes into the USB port on the switch.

Refer to the software user manual for how to use this USB port.



**The RS232 and/or USB ports may located on the bottom edge or front face of the switch**

## Section 6 Technical Specifications

### Technical Specs

Here are the hardware technical specifications for the industrial Ethernet switches covered by this manual. For the managed models, refer to the software user manual or datasheet for complete software specifications.

Note: These specifications are subject to change. Contact Red Lion for the latest details.

<b>General Specifications:</b>	
Ethernet switch type	Unmanaged or managed with up to 18 ports
Operating mode	Store and forward, wire-speed switching, non-blocking
Devices supported	All IEEE 802.3 compliant devices are supported
Protocols (managed models only)	SNMPv1/v2/v3, RMON, DHCP, SNTP, TFTP, STP, RSTP, QoS/CoS/ToS/DS, IGMPv1/v2, VLAN (tag and port based), HTTP, HTTPS (SSL & TSL), Telnet, SSH and more
Industrial protocols supported	Modbus/TCP, EtherNet/IP, PROFINet, Foundation Fieldbus HSE and others
Standards (depends on model)	IEEE 802.3, 802.3u, 802.3ab/z, 802.3x, 802.1D/w, 802.1p, 802.1Q and others
Management interfaces (managed models only)	Web (see online demo), text (Telnet & SSH), CLI (command line interface) and SNMP (see software manual for supported MIBs)
Open source linux (managed models only)	The Linux Advantage – Contact Red Lion for more information
MAC addresses	1024 on unmanaged (ES) models; 2048 on managed (MS)models; 8192 on Gigabit (MG) models
Memory bandwidth	3.2 Gbps on ES & MS models; 32 Gbps on MG models
Latency for 10 Mbps	16 us + frame time (typical)
Latency for 100/1000 Mbps	<5 us + frame time (typical)
Ethernet isolation	1500 VRMS 1 minute
Management serial port (managed models only)	RS232 (TXD, RXD and GND), 9600, 8, N, 1 fixed and/or mini-USB

<b>Copper RJ45 Ports: (10/100 Mbps or 10/100/1000 Mbps)</b>	
Copper ports	Shielded RJ45
Speed	10/100 Mbps or 10/100/1000 Mbps (depending on model)
Protocols supported	All standard IEEE 802.3
Auto-crossover	Yes, allows you to use straight or cross wired cables
Auto-sensing operation	Yes, Full and half duplex
Auto-negotiating	Yes, 10BaseT and 100BaseT
Auto-polarity	Yes, on the TD and RD pair
Flow control	Automatic
Ethernet isolation	1500 VRMS 1 minute
Plug and play	Yes
Cable requirements	Twisted pair (Cat. 5 or better) (shielded recommended)
Max. cable distance	100 meters
<b>PoE Models</b>	
Power input with reverse polarity protection	10-44 VDC with no PoE output 45-52 VDC for PoE output

Switch power consumption (typical all ports active at 1000 Mbps)	4.3 W (SLX-5EG-1) + PoE 6.2 W (SLX-5EG-2SFP) + PoE
PoE power consumption	Up to 15.4 W per port
RJ45 pin assignments for PoE	TX/V- (3, 6); RX/V+ (1, 2)
Power input transient protection	15,000 watts peak
Power input spike Protection	5,000 watts (10 times for 10 uS)
PoE operation	Auto power management
PoE disconnect mode	DC disconnect
PoE auto-detection	Per IEEE 802.2af
PoE protection	Over-temperature, over-current, over/under-voltage and transient

SC or ST Fiber Ports: (100BaseF multimode or singlemode)			
100BaseF ports	Up to 4		
Fiber port mode	Multimode (mm) or Singlemode (sm)		
Fiber port connector	Duplex SC or ST		
Half and full duplex	Full duplex on unmanaged models; Software configurable on managed models		
Ethernet compliance	100BaseF		
Eye safety	IEC 60825-1, Class 1; FDA 21 CFR 1040.10 and 1040.11		
<b>Fiber Mode</b>	<b>MM</b>	<b>SM</b>	<b>SM</b>
Fiber Length	2 km	30 km	60 km
TX Power Min	-23.5 dBm	-15 dBm	-5 dBm
RX Sensitivity Max	-32 dBm	-34 dBm	-35 dBm
Wavelength	1310 nm	1310 nm	1310 nm

SFP Mini-Gbic SFP (pluggable) Ports: (many types available)					
<b>Note:</b> On the Gigabit (MG) models these ports are pluggable and accept many different types of pluggable SFP (Mini-Gbic) transceiver modules for Gigabit fiber connections.					
Gigabit SFP ports	Up to 4				
Port types supported	Gigabit fiber multimode, fiber singlemode, fiber long-haul singlemode, fiber single-strand and more				
Note: 100 Mbps fiber transceiver modules are also supported on these ports.					
Fiber port connector	LC typically for fiber (depends on module)				
Half and full duplex	Software Configurable(managed models only)				
Ethernet compliance	1000BaseT and 1000BaseF (SX/LX/LH)				
Eye safety	IEC 60825-1, Class 1; FDA 21 CFR 1040.10 and 1040.11				
Fast Ethernet Transceivers					
Part Number	FMFIBER-SFP-2K	FMFIBER-SFP-4K	SMFIBER-SFP-30K	SMFIBER-SFP-60K	SMFIBER-SFP-60K
Fiber Mode	MM	MM	SM	SM	SM
Fiber Length	2 km	4 km	30 km	60 km	100 km
TX Power Min	-9 dBm	-9 dBm	-15 dBm	-5 dBm	-5 dBm
RX Sensitivity Max	-19 dBm	-30 dBm	-34 dBm	-35 dBm	-35 dBm
Wavelength	1310 nm	1310 nm	1310 nm	1310 nm	1550 nm
Laser Type	FP	FP	FP	FP	DFB

\* The nominal distance is for reference only. Use the power budget method for more accurately estimating distance.

<b>Gigabit Transceivers</b>						
Part Number	GMFIBER-SFP-500	GMFIBER-SFP-2K*	GSFIBER-SFP-10K	GSFIBER-SFP-30K	GSFIBER-SFP-50K	GSFIBER-SFP-80K
Fiber Mode	MM	MM	SM	SM	SM	SM
Fiber Length	500 m	2 km	10 km	30 km	50 km	80 km
TX Power Min	-9.5 dBm	-9 dBm	-9.5 dBm	-2 dBm	-2 dBm	0 dBm
RX Sensitivity Max	-17 dBm	-19 dBm	-20 dBm	-23 dBm	-23 dBm	-24 dBm
Wavelength	850 nm	1310 nm	1310 nm	1310 nm	1550 nm	1550 nm
Laser Type	VCSEL	FP	FP	DFB	DFB	DFB

\*Use this special singlemode transceiver with multimode fiber cable for a nominal maximum link distance of 2km. This transceiver offsets the transmitted light (so no mode conditioning patch cord is required) and is specifically for use with multimode fiber cable. It is recommended that this transceiver is used on both ends of the cable for best performance. Do not use this transceiver with singlemode fiber cable.

<b>“OK” Alarm Output (managed models only)</b>	
“OK” Output	ON if P1 and P2 have power and switch software is running
Voltage	Same as switch input voltage
Maximum current output	0.5 Amp

<b>Power Input:</b>			
Power input	Redundant Input Terminals		
Input power (typical with all ports active at 100 Mbps)	<table border="0"> <tr> <td style="vertical-align: top;">                     2.0 W (2-port converter with 1 fiber),                      3.0 W (5-port unmanaged w/ 1 fiber),                      5.0 W (6-port unmanaged w/ 2 fiber),                      4.0 W (8-port unmanaged w/ 0 fiber),                      5.0 W (9-port unmanaged w/ 1 fiber),                      8.0 W (8-port unmanaged w/ 3 fiber)                 </td> <td style="vertical-align: top;">                     3.6 W (5-port managed w/o fiber),                      5.6 W (5-port managed w/ 2 fiber),                      4.3 W (8-port managed w/ 0 fiber),                      6.3 W (8-port managed w/ 2 fiber),                      9.0 W (8-port managed w/ 4 fiber),                      12 W (8-port man. gigabit w/ 0 fiber),                      15 W (8-port man. gigabit w/ 4 fiber),                      5.0 W (10-port man. gigabit w/ 0 fiber),                      7.0 W (10-port man. gigabit w/ 2 fiber),                      7.0 W (16-port man. gigabit w/ 0 fiber),                      8.0 W (18-port man. gigabit w/ 0 fiber),                      10 W (18-port man. gigabit w/ 2 fiber)                 </td> </tr> </table>	2.0 W (2-port converter with 1 fiber), 3.0 W (5-port unmanaged w/ 1 fiber), 5.0 W (6-port unmanaged w/ 2 fiber), 4.0 W (8-port unmanaged w/ 0 fiber), 5.0 W (9-port unmanaged w/ 1 fiber), 8.0 W (8-port unmanaged w/ 3 fiber)	3.6 W (5-port managed w/o fiber), 5.6 W (5-port managed w/ 2 fiber), 4.3 W (8-port managed w/ 0 fiber), 6.3 W (8-port managed w/ 2 fiber), 9.0 W (8-port managed w/ 4 fiber), 12 W (8-port man. gigabit w/ 0 fiber), 15 W (8-port man. gigabit w/ 4 fiber), 5.0 W (10-port man. gigabit w/ 0 fiber), 7.0 W (10-port man. gigabit w/ 2 fiber), 7.0 W (16-port man. gigabit w/ 0 fiber), 8.0 W (18-port man. gigabit w/ 0 fiber), 10 W (18-port man. gigabit w/ 2 fiber)
2.0 W (2-port converter with 1 fiber), 3.0 W (5-port unmanaged w/ 1 fiber), 5.0 W (6-port unmanaged w/ 2 fiber), 4.0 W (8-port unmanaged w/ 0 fiber), 5.0 W (9-port unmanaged w/ 1 fiber), 8.0 W (8-port unmanaged w/ 3 fiber)	3.6 W (5-port managed w/o fiber), 5.6 W (5-port managed w/ 2 fiber), 4.3 W (8-port managed w/ 0 fiber), 6.3 W (8-port managed w/ 2 fiber), 9.0 W (8-port managed w/ 4 fiber), 12 W (8-port man. gigabit w/ 0 fiber), 15 W (8-port man. gigabit w/ 4 fiber), 5.0 W (10-port man. gigabit w/ 0 fiber), 7.0 W (10-port man. gigabit w/ 2 fiber), 7.0 W (16-port man. gigabit w/ 0 fiber), 8.0 W (18-port man. gigabit w/ 0 fiber), 10 W (18-port man. gigabit w/ 2 fiber)		
Input voltage (all models)	12-48 VDC @ 1.3A , Amb: T4 @ 85C		
Reverse power protection	Yes		
Transient protection	15,000 watts peak		
Spike protection	5,000 watts (10x for 10 uS)		

<b>Environmental and Compliances:</b>	
Operating temperature range	SL-2ES models: -10 to +60°C (cold startup at -10°C) SL-5/6/8/9ES model: -40 to +60°C (cold startup at -40°C) SLX-3/5EG models: -40 to +85°C (cold startup at -40°C)  SL/SLX-8MG models: -40 to +75°C (cold startup at -40°C)  SLX-5/6/8/9ES-1/2/3/4/5 models: -40 to +85°C (cold startup at -40°C) SLX-8ES-6/7 models: -40 to 75° C (cold startup at -40°C) SLX-5/8MS models: -40 to +75°C (cold startup at -40°C) SLX-10/18MG-1 models: -40 to +75°C (cold startup at -40°C) SLX-16MS-1 model: -40 to +75°C (cold startup at -40°C)  Contact Red Lion if wider ranges are needed.
Storage temperature range	-40 to +85 °C
<b>PoE Models</b>	
Power input with reverse polarity protection	10-44 VDC with no PoE output 45-52 VDC for PoE output
Switch power consumption (typical all ports active at 1000 Mbps)	4.3 W (5EG-1, all copper) typical 6.2 W (5EG-2SFP with 2 fiber) typical  66W (5EG-1) with 4 fully loaded PoE ports 53W (5EG-2SFP) with 3 fully loaded PoE ports
PoE power consumption	Up to 15.4 W per port
RJ45 pin assignments for PoE	TX/V- (3, 6); RX/V+ (1, 2)
Power input transient protection	15,000 watts peak
Power input spike Protection	5,000 watts (10 times for 10 uS)
PoE operation	Auto power management
PoE disconnect mode	DC disconnect
PoE auto-detection	Per IEEE 802.2af
PoE protection	Over-temperature, over-current, over/under-voltage and transient

<b>Mechanical:</b>	
Ingress protection	IP30 (SL models) IP40 (SLX models)
Packaging and protection	UL94V0 Lexan plastic for all plastic cased units. Aluminum w/ protective finish for all metal cased units.
Dimensions (L x W x H)	See mechanical diagrams for details
Weights (typical)	SL-2ES-2/3 and SL-5ES-1/2/3 in Lexan case – 4 oz (0.11 kg) SLX-3EG in metal case – 6 oz (0.17 kg) SLX-5ES-1/2/3 in metal case – 6 oz (0.17 kg) SLX-5EG-1/2SFP in metal case – 15.2 oz (0.43 kg) SLX-5MS-1/4/5 in metal case – 8 oz (0.23 kg) SL-6/8/9ES-1/2/3/4/5 in Lexan case – 6 oz (0.17 kg) SLX-6/8/9ES-1/2/3/4/5 in metal case – 8 oz (0.23 kg) SLX-8MS-1/4/5 in metal case – 10 oz (0.28 kg) SLX-8xS-6/7/8/9 in metal case – 11 oz (0.31 kg) SLX-8MG-1 without fiber transceivers – 16 oz (0.45 kg) SLX-8MG-1 with 4 fiber transceivers – 18 oz (0.50 kg) SLX-10MG-1 in metal case – 12 oz (0.34 kg) SLX-16MS-1 in metal case – 16 oz (0.45 kg) SLX-18MG-1 in metal case – 16 oz (0.46 kg)

## Section 7 Service Information

### Service Information

We sincerely hope that you never experience a problem with any Red Lion product. If you do need service, call Red Lion at 1-877-432-9908 for Technical Support. A trained specialist will help you to quickly determine the source of the problem. Many problems are easily resolved with a single phone call. If it is necessary to return a unit to us, an RO (Repair Order) can be obtained on the Red Lion website.

Red Lion tracks the flow of returned material with our RO system to ensure speedy service. You must include this RO number on the outside of the box so that your return can be processed immediately.

Be sure to have your original purchase order number and date purchased available.

We suggest that you give us a repair purchase order number in case the repair is not covered under our warranty. You will not be billed if the repair is covered under warranty.

Please supply us with as many details about the problem as you can. The information you supply will be written on the RO form and supplied to the repair department before your unit arrives. This helps us to provide you with the best service, in the fastest manner. Repairs are completed as soon as possible. If you need a quicker turnaround, ship the unit to us by air freight. We give priority service to equipment that arrives by overnight delivery.

We apologize for any inconvenience that the need for repair may cause you. We hope that our rapid service meets your needs. If you have any suggestions to help us improve our service, please give us a call. We appreciate your ideas and will respond to them.

#### For Your Convenience:

Please fill in the following and keep this manual with your **Red Lion** system for future reference:

P.O. #: \_\_\_\_\_ Date Purchased: \_\_\_\_\_  
Purchased From: \_\_\_\_\_  
Serial Number: \_\_\_\_\_

### Product Support

#### Technical Support:

Inside US: +1 (887) 432-9908  
Outside US: +1 (717) 767-6511  
Support: [support.redlion.net](http://support.redlion.net)  
Hours: 8:00 am to 6:00 pm EST

Red Lion Controls  
20 Willow Springs Circle  
York, PA 17406  
Website: [www.redlion.net](http://www.redlion.net)

**LIMITED WARRANTY**

(a) Red Lion Controls Inc. (the "Company") warrants that all Products shall be free from defects in material and workmanship under normal use for the period of time provided in "Statement of Warranty Periods" (available at [www.redlion.net](http://www.redlion.net)) current at the time of shipment of the Products (the "Warranty Period").

**EXCEPT FOR THE**

**ABOVE-STATED WARRANTY, COMPANY MAKES NO WARRANTY WHATSOEVER WITH RESPECT TO THE PRODUCTS, INCLUDING ANY (A) WARRANTY OF MERCHANTABILITY; (B) WARRANTY OF FITNESS FOR A PARTICULAR PURPOSE; OR (C) WARRANTY AGAINST INFRINGEMENT OF INTELLECTUAL PROPERTY RIGHTS OF A THIRD PARTY; WHETHER EXPRESS OR IMPLIED BY LAW, COURSE OF DEALING, COURSE OF PERFORMANCE, USAGE OF TRADE OR OTHERWISE.** Customer

shall be responsible for determining that a Product is suitable for Customer's use and that such use complies with any applicable local, state or federal law. (b) The Company shall not be liable for a breach of the warranty set forth in paragraph (a) if (i) the defect is a result of Customer's failure to store, install, commission or maintain the Product according to specifications; (ii) Customer alters or repairs such Product without the prior written consent of Company.

(c) Subject to paragraph (b), with respect to any such Product during the Warranty Period, Company shall, in its sole discretion, either (i) repair or replace the Product; or (ii) credit or refund the price of Product provided that, if Company so requests, Customer shall, at Company's expense, return such Product to Company.

(d) **THE REMEDIES SET FORTH IN PARAGRAPH (c) SHALL BE THE CUSTOMER'S SOLE AND EXCLUSIVE REMEDY AND COMPANY'S ENTIRE LIABILITY FOR ANY BREACH OF THE LIMITED WARRANTY SET FORTH IN PARAGRAPH (a).**

**BY INSTALLING THIS PRODUCT, YOU AGREE TO THE TERMS OF THIS WARRANTY, AS WELL AS ALL OTHER DISCLAIMERS AND WARRANTIES IN THIS DOCUMENT.**