

Data sheet

Brazed heat exchanger XB06 & Flow-compensated temperature controller IHPT (PN16)

Description

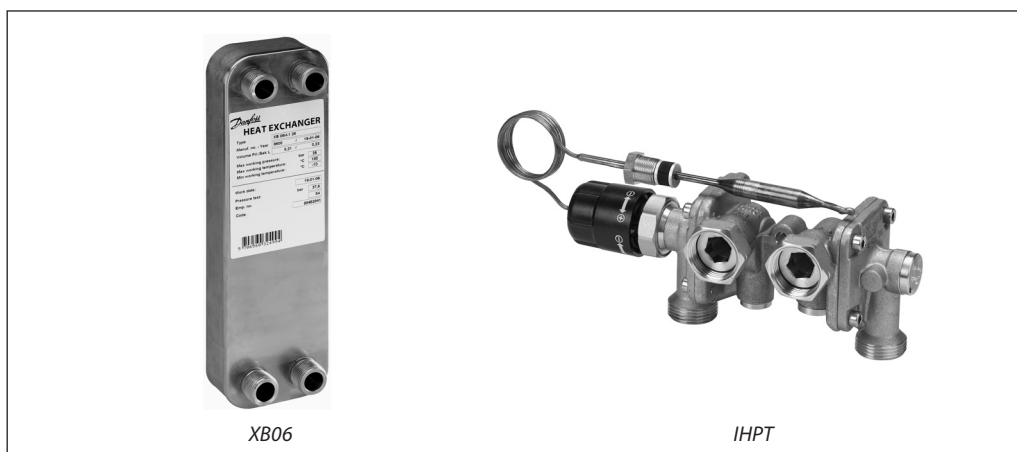

The XB is a brazed plate heat exchanger designed for use with district heating systems (i.e. air conditioning, heating, domestic hot water). XB brazed plate heat exchangers are made with several differently sized heat exchange plates.

The IHPT is flow-compensated temperature controller with Δp controller built in developed to control instantaneous heating of domestic hot water by means of heat exchanger.

Innovative design enables simple, fast and reliable connection to heat exchanger and most important production of ultra compact and user friendly stations for heating of domestic hot water service.

The capacity of controllers fully covers the needs of domestic hot water for flats, one family houses or dwellings and can be mounted to district heating network directly, to a block of heating systems or central located boiler system in a dwelling house.

The controller is connected to primary heating system as well as cold water system. To avoid risk of leaking from one media to the other the controller is equipped with double sealing. Between both sealings there is a bore to the outside of the valve. In case of leakage from one sealing the media can escape through the bore.

Typical system conditions
District heating systems with varying supply temperature plus high and varying differential pressure and where a high comfort idle temperature is requested.
Idle controller is integrated.

Controllers have:

- WRAS approval,
- ETA VA approval,
- DVGW approval.

Main data:

- DN 15
- k_{vs} 2.4, 3.0 m³/h
- PN 16
- Setting range: 45 ... 65 °C
(see Setting range section)
- Temperature:
Circulation water 2 ... 120 °C
- Connections:
- Union nut

Ordering

Example 1:
Flow-compensated temperature controller with Δp controller built in (NO), DN 15, k_{vs} 2.4, PN 16, setting range 45 ... 65 °C, union nut connection

- 1x IHPT DN 15 controller
Code No: **003L3813**

Option:
- 1x Housing of sensor stuffing box
Code No: **013U8102**

Example 2:
Flow-compensated temperature controller with Δp controller built in (NO), DN 15, k_{vs} 2.4, PN 16, setting range 45 ... 65 °C, union nut connection & brazed heat exchanger XB06 with 26 plates

- 1x Combination DN 15
Code No: **003L3900**

IHPT Controller

Picture	DN	k_{vs} (m ³ /h)	Setting range ³⁾ (°C)	Connection ¹⁾	Code No. ²⁾
	15	2.4	45 ... 65	Union nut	003L3813
		3.0			003L3815

- ¹⁾ to heat exchanger
- ²⁾ Controller is delivered with thermostatic actuator with standard sensor and M14 sensor stuffing box (housing of sensor stuffing box is not delivered, it is available as an accessory)
- ³⁾ see Setting range section

IHx Controllers, 90° version - Damped ¹⁾

Picture	Type	DN	k_{vs} (m ³ /h)	Setting range ⁴⁾ (°C)	Connection ²⁾	Code No.
	IHPT ³⁾	15	2,4	45 ... 65	Union nut	003L3875
			3,0			003L3877

- ¹⁾ For details see "Selection guideline" section
- ²⁾ to heat exchanger
- ³⁾ Controller is delivered with thermostatic actuator with standard sensor and M14 sensor stuffing box (housing of sensor stuffing box is not delivered, it is available as an accessory)
- ⁴⁾ see Setting range section

XB06 & IHPT

Picture	Type	DN	k_{vs} (m ³ /h)	Setting range ³⁾ (°C)	Heat exchanger type		
					XB 06H-1-26	XB 06H-1-30	XB 06H-1-36
Combination Code No. ²⁾							
	IHPT ¹⁾	15	2.4	45 ... 65	003L3900	003L3901	003L3902
			3.0		003L3903	003L3904	003L3905

- ¹⁾ Controller is delivered with standard sensor and R_p 1/2" sensor stuffing box incl. housing of sensor stuffing box
- ²⁾ Code number includes one IHPT and one heat exchanger
- ³⁾ see Setting range section

IHPT & XB06 (II)

Picture	Type	DN	k_{vs} (m ³ /h)	Setting range ³⁾ (°C)	Heat exchanger type	
					XB 06H-1-16	XB 06H-1-26
Combination Code No. ²⁾						
	IHPT ¹⁾	15	2.4	45 ... 65	003L3920	
			3.0		003L3921	

- ¹⁾ Controller is delivered with standard sensor and R_p 1/2" sensor stuffing box incl. housing of sensor stuffing box
- ²⁾ Code number includes one IHPT and two heat exchangers
- ³⁾ see Setting range section

Accessories

Type designations	Code No.
Housing of sensor stuffing box ¹⁾	013U8102

- ¹⁾ Code includes housing and gasket of sensor stuffing box; R 1/2 x M14 x 1 mm, rubber EPDM \varnothing 12,6 x 4 x 6 mm

Service kits

Type designations	Setting range (°C)	Code No. ¹⁾ for IHPT
Service thermostat	40 ... 60	003L3868
Thermostatic actuator with standard sensor	45 ... 65	003L3833

- ¹⁾ For details see "Installation positions" section; sensor is delivered with M14 sensor stuffing box

Technical data *

* Data for XB06 see relevant Data sheet

Nominal diameter	DN	15		
k_{VS} value of thermostatic controller ($k_{VS,TC}$)	m ³ /h	2.4	3.0	
k_{VS} value of built in Δp controller ($k_{VS,DP}$)		5.0		
Controlled Δp on thermostatic controller (Δp_{TC})	bar	0.16		
Min. flow rate on primary side ($Q_{1,min}$)	l/h	70	100	
Max. flow rate on primary side ($Q_{1,max}$)		1000	1200	
Min. flow rate on secondary side ($Q_{2,min}$)		120		
Max. rec. flow rate on secondary side ($Q_{2,max}$)		1400 ⁴⁾		
Nominal pressure	PN	16 ³⁾		
Max. differential pressure on primary side	bar	6.0		
Max. rec. differential pressure on secondary side		1.0		
Medium	Circulation water / glycolic water up to 30% ¹⁾ Domestic hot water (chlorine (cl) content max. 200 ppm) ²⁾			
Medium pH	Min. 7, max. 10 ³⁾			
Medium temperature	°C	2 ... 120		
Setting range		45 ... 65		
Idle temperature		$T_{set} - 8\text{ }^{\circ}\text{C}$		
Max. adm. temperature at sensor		120		
Capillary tube length		m	0.6	
Materials				
Housings	CuZn36Pb2As (CW 602N)			
Cone and diaphragm support	MPPE (Noryl)			
Main spindle	Stainless steel, mat. No. 1.4404			
Diaphragm, O-rings	EPDM			
Temperature sensor	Copper, mat. No. 2.0090			

- ¹⁾ Valid for primary side
²⁾ Valid for secondary side
³⁾ On primary and secondary side
⁴⁾ at diff. pressure on secondary side (Δp_2) 1 bar

Classification according to VDI 6003

Type	Wash basin ¹⁾	Showers ²⁾
IHPT	III	III

- ¹⁾ Tapping rate changing in steps of 6-12-6 l/min.
²⁾ Tapping rate changing in steps of 9-12-9 l/min.

The min. required differential pressure across primary side of the controller is calculated from the formula:

$$\Delta p_{PRIM,min} = \left(\frac{Q_{PRIM,max}}{k_{VS,DP}} \right)^2 + \Delta p_{TC}$$

In graph pressure drop on secondary side in relation to the secondary flow can be seen.

* TC - thermostatic controller

Quick suggestion:

If the max. flow rate on primary side is below 1 m³/h (1000 l/h) always choose $k_{VS} = 2.4$ m³/h and if it is higher then choose $k_{VS} = 3.0$ m³/h.

Measured for constant supply temperature of 75 °C and system differential pressure of 0.5 bar.

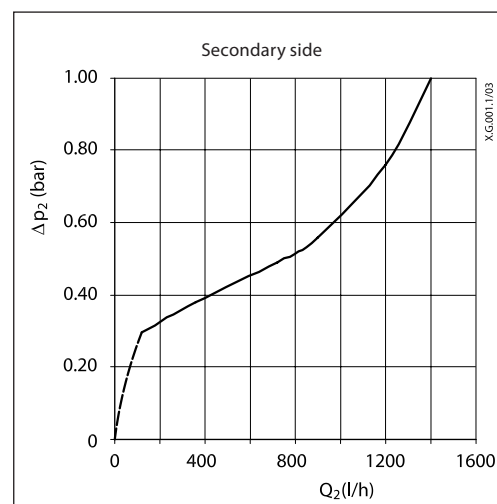

Setting range

Temperature setting depends on application parameters. Values given are approximate.

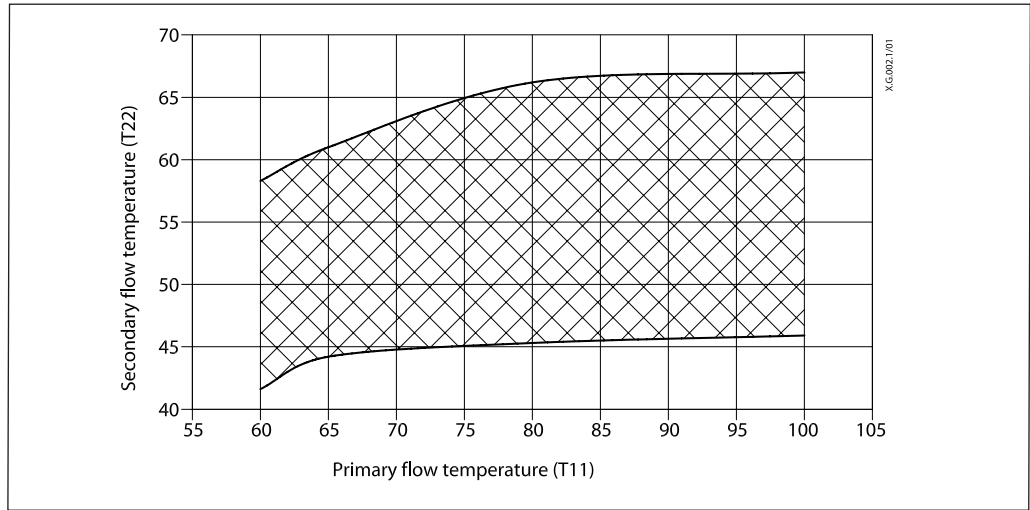

Application scheme

Functions

Flow-compensated temperature controller with differential pressure controller built in (NO)

Typical system conditions

District heating systems with varying supply temperature plus high and varying differential pressure and where a high comfort idle temperature is requested.

Idle control alternatives

Idle controller is built in.

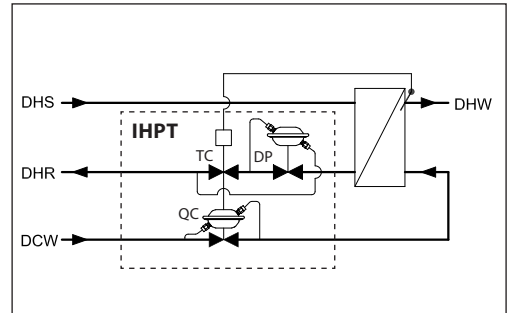

Application principle

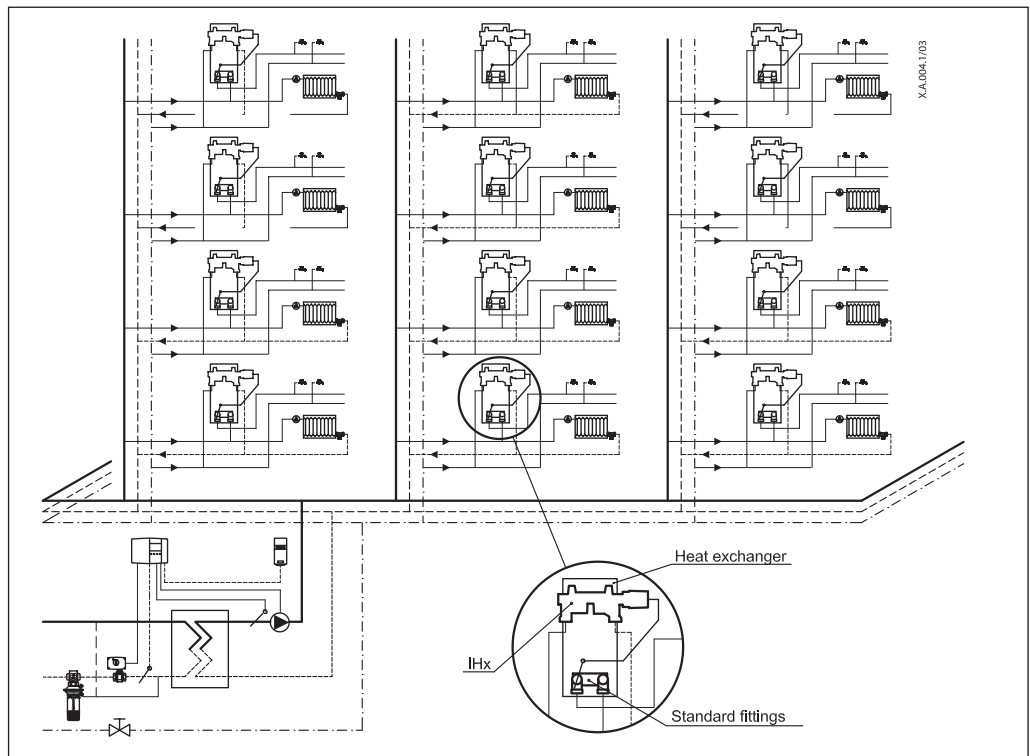

Sensor installation

Temperature controller

Controller must be mounted on cold side of heat exchanger (district heating outlet and domestic cold water inlet side).

IHPT, Termix TPV controllers are delivered with standard sensor.

Standard sensor

The sensor must always be placed warmer than the controller.

Temperature sensor

Can be mounted on any direction. For best performance it is recommended to install the sensor facing up.

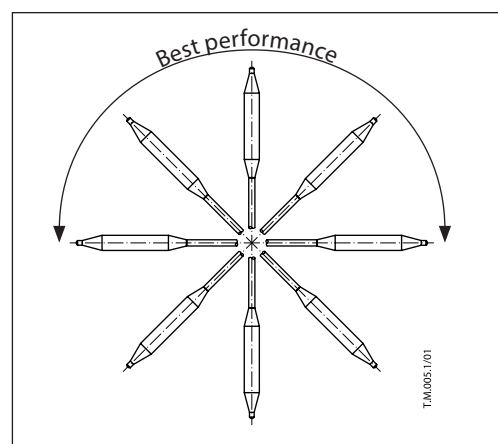

Strainers installation

It is strongly recommended to install strainers on both the cold water pipeline and the district heating supply line.

Sizing

Example

Instantaneous domestic hot water production requires primary flow of 800 l/h. Minimum system differential pressure is 0.8 bar.

Given data:

- $Q_{PRIM,max} = 0.8 \text{ m}^3/\text{h} \text{ (800 l/h)}$
- $\Delta p_{syst,min} = 0.8 \text{ bar (80 kPa)}$
- $\Delta p_{exchanger} = 0.1 \text{ bar (10 kPa)}$

The total (available) pressure loss across the primary side of the controller is:

$$\Delta p_{PRIM,A} = \Delta p_{syst,min} - \Delta p_{exchanger} = 0.8 - 0.1$$

$$\Delta p_{PRIM,A} = 0.7 \text{ bar (70 kPa)}$$

Possible pipe pressure losses in tubes, shut-off fittings, heatmeters, etc. are not included.

Select controller acc. to technical data, page 3, with the smallest possible k_{vs} value considering available flow ranges:

$$k_{vs,TC} = 2.4 \text{ m}^3/\text{h}$$

The other relevant data for this controller are:

- $k_{vs,DP} = 5.0 \text{ m}^3/\text{h}$
- $\Delta p_{TC} = 0.16 \text{ bar (16 kPa)}$

The min. required differential pressure across primary side of the selected controller is calculated from the formula:

$$\Delta p_{PRIM,min} = \left(\frac{Q_{PRIM,max}}{k_{vs,DP}} \right)^2 + \Delta p_{TC} = \left(\frac{0.8}{5} \right)^2 + 0.16$$

$$\Delta p_{PRIM,min} = 0.19 \text{ bar (19 kPa)}$$

$$\Delta p_{PRIM,A} > \Delta p_{PRIM,min}$$

$$0.7 \text{ bar} > 0.19 \text{ bar}$$

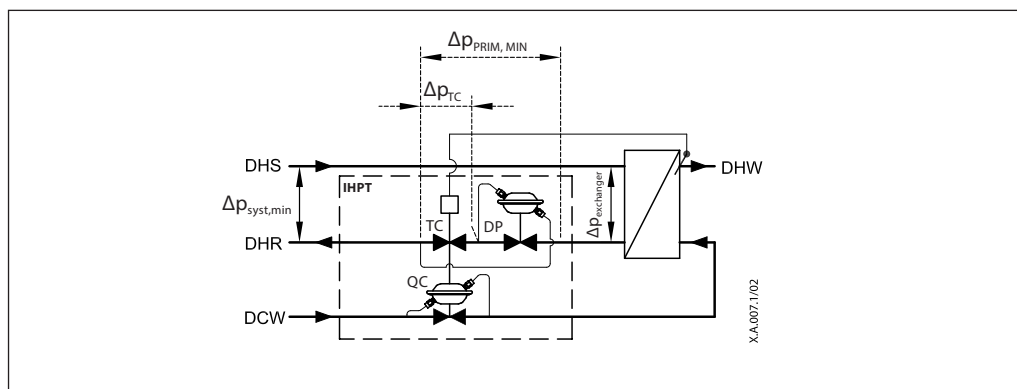

Design

1. Secondary side cone (QC)
2. Moving seat
3. Main body
4. O-ring
5. Differential pressure cone (DP)
6. Main spindle
7. Primary side cone (TC)
8. Stuffing box
9. Thermostat
10. Handle for temperature setting
11. Secondary side body
12. Circulation connection plug (3/8")
13. Temperature sensor
14. Differential pressure moving seat
15. Washer of sensor stuffing box
16. Gasket of sensor stuffing box
17. Sealing bolt of sensor stuffing box
18. Primary side body
19. Housing of sensor stuffing box

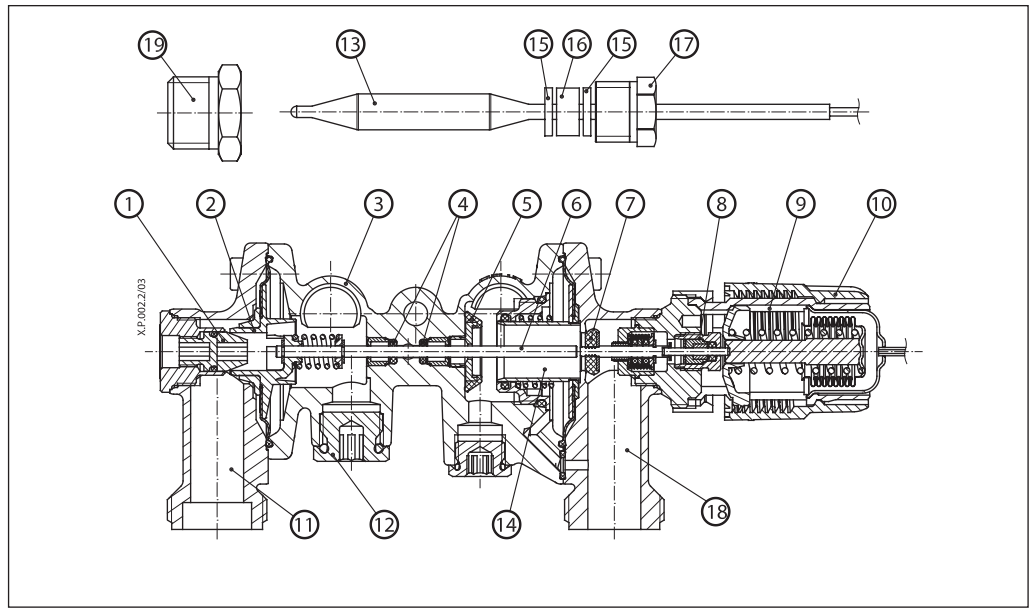

Function

The controller has three main functions that can be mounted in the controller based on application demands:

- QC** Proportional flow controller
- TC** Thermostatic controller
- DP** Differential pressure controller

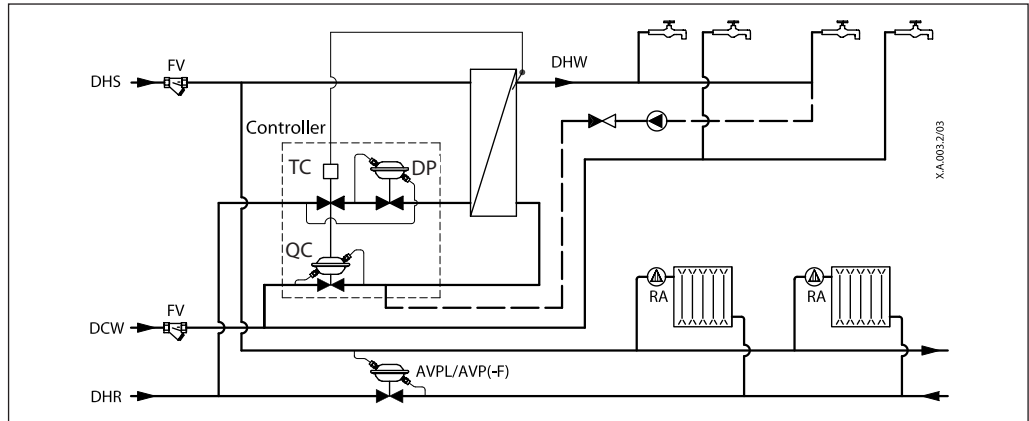

To minimise the risk of calcium deposits on cold water side and sensitivity to high temperatures the controller is mounted on cold side of heat exchanger (district heating outlet and domestic cold water inlet side). In standard applications at standard conditions with Danfoss heat exchanger XB 06 primary return temperature is below 30 °C.

Function (continuous)

Flow-compensated temperature controller IHPT with integrated differential pressure controller

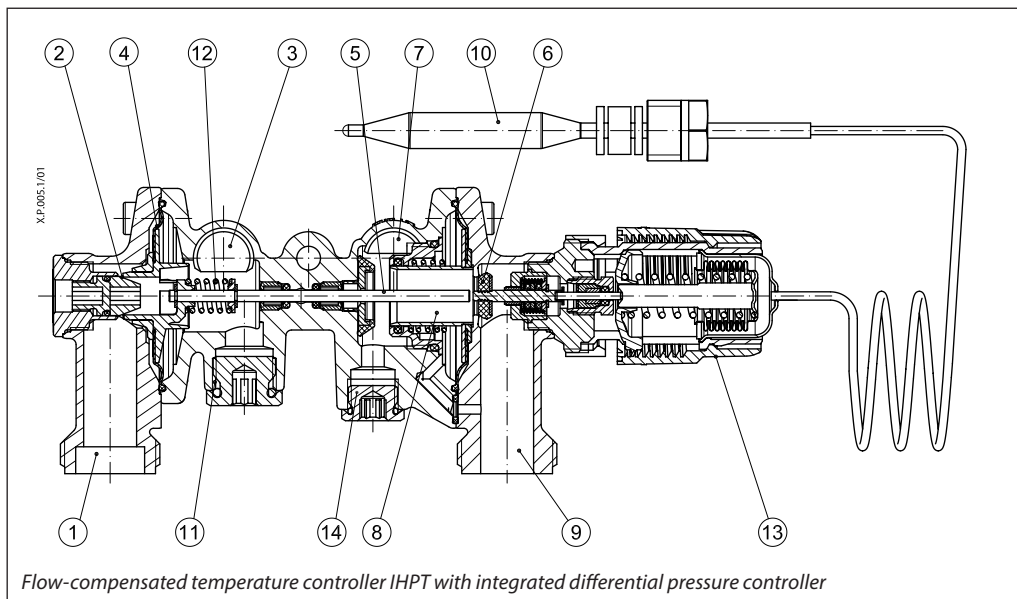

When tapping starts, cold water flows into secondary side of controller (1) passes the secondary side cone (QC) (2), leaves the controller (3) and enters the heat exchanger. The pressure drop generated on the orifice is transferred to the diaphragm (4) which transfers the force to the spring (12). This results in moving of the main spindle (5) to the right which opens the primary side cone (6).

The opening results in primary flow entering into controller (7), passing integrated differential pressure controller (DP) (8), primary side cone (TC) (6) and leaving controller (9).

The temperature sensor (10), mounted to the secondary hot water side is sensing the temperature. If the temperature is deviating from setting temperature the thermostatic element (13) will move (open/close) primary side cone (6) until desired temperature is reached. Not to influence on tapping flow from thermostatic adjustments the spring (12) is mounted between main spindle (5) and diaphragm which can be compressed when needed.

When no load (no flow on secondary side) the controller maintains constant temperature in the heat exchanger few degrees below adjusted temperature (idle temperature).

The differential pressure controller (8) controls the pressure over control valve and therefore enables 100 % authority of the controller in all conditions.

By rotating the handle for temperature setting (13) the temperature of tapping flow can be adjusted.

Domestic hot water circulation (11) connections are placed directly on the controller and therefore minimize the costs for mounting and optimize space for the piping.

Settings

Temperature setting

Temperature setting is adjusted with handle for temperature setting.

By turning it in (+) direction the setting is increased, by turning it in (-) direction the setting is decreased.

Mounting specifics

Connections to heat exchanger

Union nut connection

Second option is with union nuts to standard threaded heat exchanger connections (fig.1) which have distance between them 45 mm. In order to cover the tolerances of heat exchanger production special union nuts were developed which can tolerate dimensions of $45 \pm 1,5$ mm (C) (Factory assembled). In this case standard fittings (D) should be used on hot side of heat exchanger.

Connections to pipes (E)

For connecting controller to station $\frac{3}{4}$ " connections are used.

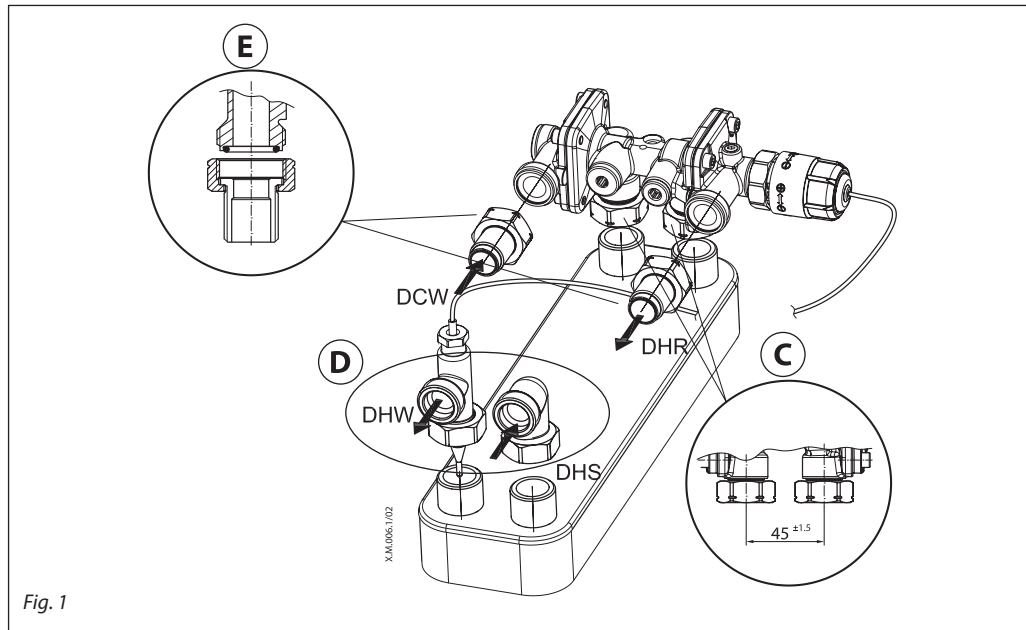

Dimensions

