

Type 8025 - 8035 - SE35 BATCH

Batch controller
Dosiergerät
Contrôleur de dosage



Operating Instructions

Bedienungsanleitung
Manuel d'utilisation

We reserve the right to make technical changes without notice.
Technische Änderungen vorbehalten.
Sous réserve de modifications techniques.

© Bürkert SAS, 2013 - 2016

Operating Instructions 1608/3_EU-ML 00564510 / Original FR

1	ABOUT THESE OPERATING INSTRUCTIONS	9
1.1	Symbols used	9
1.2	Definition of the word "device"	10
1.3	Validity of these Operating Instructions	10
2	INTENDED USE	10
3	BASIC SAFETY INFORMATION	11
4	GENERAL INFORMATION	12
4.1	Manufacturer's address and international contacts	12
4.2	Warranty conditions	12
4.3	Information on the Internet	12
5	DESCRIPTION	13
5.1	Area of application	13
5.2	Construction of the device	13
5.2.1	Construction of the 8025 Batch in compact version	13
5.2.2	Construction of the 8025 Batch in panel version	14
5.2.3	Construction of the 8025 Batch in wall-mounted version	14
5.2.4	Construction of the SE35 Batch	14
5.2.5	Construction of the 8035 Batch	14
5.2.6	Construction of the SE35 Batch with sensor-fitting S070 or S077	15
5.3	Description of the name plate	15
6	TECHNICAL DATA	16
6.1	Technical data of the dosing controller 8025 Batch in compact version	16
6.1.1	Conditions of use of a 8025 Batch in compact version	16
6.1.2	Conformity to standards and directives of a 8025 Batch in compact version	16
6.1.3	Fluid data of a 8025 Batch in compact version	17
6.1.4	Material data of a 8025 Batch in compact version	18
6.1.5	Dimensions of a 8025 Batch in compact version	18
6.1.6	Electrical data of a 8025 Batch in compact version	18
6.2	Technical data of the dosing controller 8025 Batch in panel version	19
6.2.1	Conditions of use of a 8025 Batch in panel version	19
6.2.2	Conformity to standards and directives of a 8025 Batch in panel version	19

6.2.3	Material data of a 8025 Batch in panel version	20
6.2.4	Dimensions of a 8025 Batch in panel version	20
6.2.5	Electrical data of a 8025 Batch in panel version	20
6.2.6	Specifications of a remote flow sensor connected to a 8025 Batch in panel version	21
6.3	Technical data of the dosing controller 8025 Batch in wall-mounted version	22
6.3.1	Conditions of use of a 8025 Batch in wall-mounted version	22
6.3.2	Conformity to standards and directives of a 8025 Batch in wall-mounted version	22
6.3.3	Material data of a 8025 Batch in wall-mounted version	22
6.3.4	Dimensions of a 8025 Batch in wall-mounted version	23
6.3.5	Electrical data of a 8025 Batch in wall-mounted version	23
6.3.6	Specifications of a remote flow sensor connected to a 8025 Batch in wall-mounted version	24
6.4	Technical data of the dosing controller SE35 Batch	25
6.4.1	Conditions of use of a SE35 Batch	25
6.4.2	Conformity to standards and directives of a SE35 Batch	25
6.4.3	Material data of a SE35 Batch	25
6.4.4	Dimensions of a SE35 Batch	26
6.4.5	Electrical data of a SE35 Batch	26
6.5	Technical data of the dosing controller 8035 Batch	27
6.5.1	Conditions of use of a 8035 Batch	27
6.5.2	Conformity to standards and directives of a 8035 Batch	27
6.5.3	Fluid data of a 8035 Batch	28
6.5.4	Material data of a 8035 Batch	29
6.5.5	Dimensions of a 8035 Batch	29
6.5.6	Electrical data of a 8035 Batch	29
6.6	Technical data of the dosing controller SE35 Batch associated with a sensor-fitting S070 or S077	30
6.6.1	Conditions of use of a SE35 Batch with a S070 or a S077	30
6.6.2	Conformity to standards and directives of a SE35 Batch with a S070 or a S077	30
6.6.3	Fluid data of a SE35 Batch with a S070 or a S077	31
6.6.4	Material data of a SE35 Batch with a S070 or a S077	32
6.6.5	Dimensions of a SE35 Batch with a S070 or a S077	32
6.6.6	Electrical data of a SE35 Batch with a S070 or a S077	32
7	FLUID INSTALLATION	33
7.1	Safety instructions	33

7.2	Installation of the dosing controller type 8025 Batch in compact version	34
7.2.1	Install the S020 fitting on the pipes	34
7.2.2	Install the 8025 Batch in compact version into the S020 fitting	35
7.2.3	Finalise the installation of the 8025 Batch in compact version.	35
7.3	Installation of the dosing controller 8035 Batch	36
7.3.1	Install the S030 sensor-fitting on the pipes	36
7.3.2	Install the dosing controller SE35 Batch on the sensor-fitting S030	36
7.3.3	Finalise the installation of the 8035 Batch	37
7.4	Installation of the dosing controller SE35 Batch on the sensor-fitting S070 or S077	37
7.4.1	Install the sensor-fitting S070 or S077 on the pipes	37
7.4.2	Install the dosing controller SE35 Batch on the sensor-fitting S070 or S077	38
7.4.3	Finalise the installation	38
7.5	Installation of the dosing controller 8025 Batch in panel version	38
7.6	Installation of the dosing controller 8025 Batch in wall-mounted version.....	40
8	ELECTRICAL INSTALLATION AND WIRING	41
8.1	Safety instructions	41
8.2	Specifications of the connection cables	42
8.2.1	Dosing controller 8025 Batch in compact version, 8035 Batch and SE35 Batch	42
8.2.2	Dosing controller 8025 Batch in panel version	43
8.2.3	Dosing controller 8025 Batch in wall-mounting version	43
8.3	Equipotentiality of the installation	43
8.4	Default position of the selectors.....	45
8.5	Terminal assignment and use of the selectors	45
8.6	Wiring the 8025 Batch in compact version, the 8035 Batch or the SE35 Batch	49
8.7	Wiring the 8025 Batch in panel version	51
8.8	Wiring the 8025 Batch in wall-mounted version	51
8.9	Connecting the remote flow sensor to a 8025 Batch in panel-mounted or in wall-mounted version	53
8.10	Wiring the digital inputs DI1 to DI4 and the transistor output DO4	55
8.11	Wiring the DO1 transistor output of device, fed with 12...36 V DC	56
8.12	Wiring the DO1 transistor output of a version fed with 115/230 V AC for the 8025 Batch in compact version, for the 8035 Batch or for the SE35 Batch	56
8.13	Wiring the DO1 transistor output of the 8025 Batch in wall-mounted version, fed with 115/230 V AC	57

8.14	Wiring the relay outputs DO2 and DO3 of a device	59
9	COMMISSIONING	60
9.1	Safety instructions	60
9.2	Commissioning procedure	60
10	OPERATING AND FUNCTIONS	61
10.1	Safety instructions	61
10.2	Operating levels of the device.....	61
10.3	Description of the navigation keys and the state LEDs.....	63
10.4	Using the navigation keys.....	64
10.5	Principle of a dosing and PLC scenarios	65
10.6	Details of the Process level	68
10.6.1	Doing a dosing in dosing mode "LOC. MANU." or "MEM.+MANU."	69
10.6.2	Doing a dosing in dosing mode "LOC. MEM." or "MEM.+MANU."	71
10.6.3	Doing a dosing in dosing mode "EXT. MEM."	73
10.6.4	Doing a dosing in dosing mode "EXT.+LOC."	77
10.6.5	Doing a dosing in dosing mode "EXT. [T]"	81
10.6.6	Doing a dosing in dosing mode "EXT. REP."	84
10.6.7	Doing a dosing in dosing mode "LOC. REP."	87
10.7	Details of the Parameters menu.....	89
10.7.1	Choosing the display language.....	90
10.7.2	Choosing the dosing units, the flow rate units, the units and number of decimals of the volume or mass totalizers.....	90
10.7.3	Entering the K-factor of the fitting used	92
10.7.4	Determining the fitting K-factor using a Teach-In procedure	92
10.7.5	Configuring the dosing mode (general diagram).....	95
10.7.6	Configuring the dosing mode "LOC. MANU."	96
10.7.7	Configuring the dosing mode "LOC. MEM."	96
10.7.8	Configuring the dosing mode "MEM+MANU"	96
10.7.9	Configuring the dosing mode "EXT. MEM."	97
10.7.10	Configuring the dosing mode "EXT. +LOC"	97
10.7.11	Configuring the dosing mode "EXT. [T]"	97
10.7.12	Configuring the dosing mode "EXT. REP"	99
10.7.13	Configuring the dosing mode "LOC. REP.".....	101
10.7.14	Entering the dosing quantities in the device memory	103

10.7.15	Configuring the overflow correction or deactivating it	103
10.7.16	Activating / deactivating the generation of alarms for problems occurring during a dosing	105
10.7.17	Activating / deactivating the generation of alarms for problems occurring at the end of a dosing	106
10.7.18	Configuring the outputs (general diagram)	107
10.7.19	Configuring the transistor output DO1 or DO4 or the relay output DO3 to switch when an alarm is generated during or at the end of a dosing	108
10.7.20	Configuring the transistor output DO1 or DO4 or the relay output DO3 to switch when a warning message is emitted by the device	109
10.7.21	Configuring the transistor output DO1 or DO4 or the relay output DO3 to signal the end of the dosing	109
10.7.22	Configuring the transistor output DO1 or DO4 as a pulse output proportional to a volume or a mass	110
10.7.23	Configuring the transistor output DO1 or DO4 to transmit the rotational frequency of the paddle wheel	111
10.7.24	Configuring the relay output DO2	112
10.7.25	Configuring the relay output DO3 to control an auxiliary valve	113
10.7.26	Configuring the transistor output DO4 to transmit the device state and activating / deactivating the generation of a 10 Hz frequency when an error message is generated by the device	113
10.7.27	General diagram of the "RESET" sub-menu	114
10.7.28	Resetting the two volume or mass totalizers	115
10.7.29	Resetting the two totalizers of the done dosings	115
10.7.30	Clearing the history table of the done dosings	116
10.7.31	Setting the brightness of the display and how long it stays ON, or deactivating the backlight	116
10.8	Details of the Test menu	117
10.8.1	Checking the inputs functions	118
10.8.2	Checking the outputs functions	118
10.8.3	Checking the paddle-wheel operation	119
10.8.4	Monitoring the flow rate in the pipe	120
10.8.5	Monitoring the value of the daily volume or mass totalizer	121
10.8.6	Monitoring the number of done dosings	121
10.8.7	Saving the user set configuration	122
10.8.8	Restoring the saved configuration	122
10.8.9	Restoring the default configuration	122
10.9	Details of the History menu	124
10.10	Details of the Information menu	124
10.11	Remote consultation and confirmation of the warning messages	125

11	MAINTENANCE AND TROUBLESHOOTING.....	128
11.1	Safety instructions	128
11.2	Cleaning the device	128
11.3	If you encounter problems	128
11.3.1	Resolution of problems when the device state LED is OFF.....	128
11.3.2	Resolution of problems related to an error message and the device state LED is red .	129
11.3.3	Resolution of problems related to a warning message and the device state LED is orange	130
11.3.4	Resolution of a problem occurring during a dosing	131
11.3.5	Resolution of problems without message generation and the device status LED is green	133
11.3.6	Resolution of problems linked to warning messages not registered in the Information menu	133
12	SPARE PARTS AND ACCESSORIES.....	135
13	PACKAGING, TRANSPORT.....	138
14	STORAGE	138
15	DISPOSAL OF THE DEVICE	138

1 ABOUT THESE OPERATING INSTRUCTIONS

These Operating Instructions describes the entire life cycle of the device. Please keep these Operating Instructions in a safe place, accessible to all users and any new owners.

These Operating Instructions contains important safety information.

Failure to comply with these instructions can lead to hazardous situations. Pay attention in particular to the chapters [3 Basic safety information](#) and [2 Intended use](#).

- ▶ Whatever the version of the device, these Operating Instructions must be read and understood.
- ▶ When the symbol  is marked inside or outside the device, carefully read the Operating Instructions.

1.1 Symbols used



DANGER

Warns against an imminent danger.

- ▶ Failure to observe this warning can result in death or in serious injury.



WARNING

Warns against a potentially dangerous situation.

- ▶ Failure to observe this warning can result in serious injury or even death.



ATTENTION

Warns against a possible risk.

- ▶ Failure to observe this warning can result in substantial or minor injuries.

NOTE

Warns against material damage.



Indicates additional information, advice or important recommendations.



Refers to information contained in these Operating Instructions or in other documents.

- ▶ Indicates an instruction to be carried out to avoid a danger, a warning or a possible risk.

→ Indicates a procedure to be carried out.

- ☑ Indicates the result of a specific instruction.

1.2 Definition of the word "device"

The word "device" used within these Operating Instructions always refers to:

- the dosing controller type 8025 Batch in compact version,
- the dosing controller type 8025 Batch in panel version,
- the dosing controller type 8025 Batch in wall-mounted version,
- the dosing controller type 8035 Batch or
- the dosing controller type SE35 Batch.

1.3 Validity of these Operating Instructions

The Operating Instructions are valid for the following devices:

- serial numbers higher or equal to 20 000.

2 INTENDED USE

Use of the device that does not comply with the instructions could present risks to people, nearby installations and the environment.

The device installed in series with one or two valves, has been designed to do the dosing of one or several quantities (volumes or masses) of a liquid.

- ▶ Protect this device against electromagnetic interference, ultraviolet rays and, when installed outdoors, the effects of climatic conditions.
- ▶ Use this device in compliance with the characteristics and commissioning and use conditions specified in the contractual documents and in the operating instructions.
- ▶ Never use this device for security applications.
- ▶ Requirements for the safe and proper operation of the device are proper transport, storage and installation, as well as careful operation and maintenance.
- ▶ Only operate a device in perfect working order.

3 BASIC SAFETY INFORMATION

This safety information does not take into account:

- any contingencies or occurrences that may arise during installation, use and maintenance of the devices.
- the local safety regulations for which the operating company is responsible including the staff in charge of installation and maintenance.



Danger due to electrical voltage.

- ▶ If a 12...36 V DC powered version is installed either in a wet environment or outdoors, all the electrical voltages must be of max. 35 V DC.
- ▶ Disconnect the electrical power for all the conductors and isolate it before carrying out work on the system.
- ▶ All equipment connected to the wall-mounted or panel version of the flow transmitter 8025 must be double insulated in relation to the mains in accordance with IEC standard 61010-1:2010.
- ▶ Observe all applicable accident protection and safety regulations for electrical equipment.

Risk of injury due to high pressure in the installation.

- ▶ Stop the circulation of fluid, cut off the pressure and drain the pipe before loosening the process connections.
- ▶ Observe the fluid temperature/pressure dependency depending on the fitting used.

Risk of injury due to high fluid temperatures.

- ▶ Use safety gloves to handle the device.
- ▶ Stop the circulation of fluid and drain the pipe before loosening the process connections.

Risk of injury due to the nature of the fluid.

- ▶ Respect the prevailing regulations on accident prevention and safety relating to the use of aggressive fluids.



Various dangerous situations

To avoid injury take care:

- ▶ not to use the device in explosive atmospheres.
- ▶ not to use the device in an environment incompatible with the materials it is made of.
- ▶ not to use fluid that is incompatible with the materials the device is made of.
- ▶ not to subject the device to mechanical loads.
- ▶ not to make any modifications to the device.
- ▶ to prevent any unintentional power supply switch-on.
- ▶ to carry out the installation and maintenance work by qualified and skilled staff with the appropriate tools.
- ▶ to guarantee a defined or controlled restarting of the process, after a power supply interruption.
- ▶ to observe the general technical rules when installing and using the device.

NOTE

The device may be damaged by the fluid in contact with.

- ▶ Systematically check the chemical compatibility of the component materials of the device and the fluids likely to come into contact with it (for example: alcohols, strong or concentrated acids, aldehydes, alkaline compounds, esters, aliphatic compounds, ketones, halogenated aromatics or hydrocarbons, oxidants and chlorinated agents).

NOTE

Elements / Components sensitive to electrostatic discharges

This device contains electronic components sensitive to electrostatic discharges. They may be damaged if they are touched by an electrostatically charged person or object. In the worst case scenario, these components are instantly destroyed or go out of order as soon as they are activated.

- ▶ To minimise or even avoid all damage due to an electrostatic discharge, take all the precautions described in standard EN 61340-5-1.
- ▶ Also ensure that you do not touch any of the live electrical components.

4 GENERAL INFORMATION

4.1 Manufacturer's address and international contacts

To contact the manufacturer of the device, use following address:

Bürkert SAS

Rue du Giessen

BP 21

F-67220 TRIEMBACH-AU-VAL

You may also contact your local Bürkert sales office.

The addresses of our international sales offices are available on the internet at: www.burkert.com

4.2 Warranty conditions

The condition governing the legal warranty is the conforming use of the device in observance of the operating conditions specified in these operating instructions.

4.3 Information on the Internet

You can find the Operating Instructions and technical data sheets regarding the type 8025 Batch, 8035 Batch and SE35 Batch at: www.burkert.com

5 DESCRIPTION

5.1 Area of application

When mounted in series with one or two valves the device enables the dosing of one or several quantities of a liquid.

It controls the opening or closing of the valves via the relay outputs and counts the quantity of flown liquid.

The dosing is done either locally by pressing the navigation keys under the display or remotely by a PLC via one up to four digital inputs.

The dosing principle is described in chap. [10.5](#).

The eight available dosing modes are described in chap. [10.6](#).

5.2 Construction of the device

The device has:

- four digital inputs (called DI1 to DI4),
- two transistor outputs (called DO1 and DO4, which can be parametered),
- two relay outputs (called DO2 and DO3, which can be parametered) and
- four totalizers (two volume or mass totalizers and two totalizers of the done dosings).

Depending on the version the device is energized by a 12...36 V DC or a 115/230 V AC power supply.

Electrical connection is made on the terminal blocks of the electronic board, either directly or via 2 or 5 cable glands.

5.2.1 Construction of the 8025 Batch in compact version

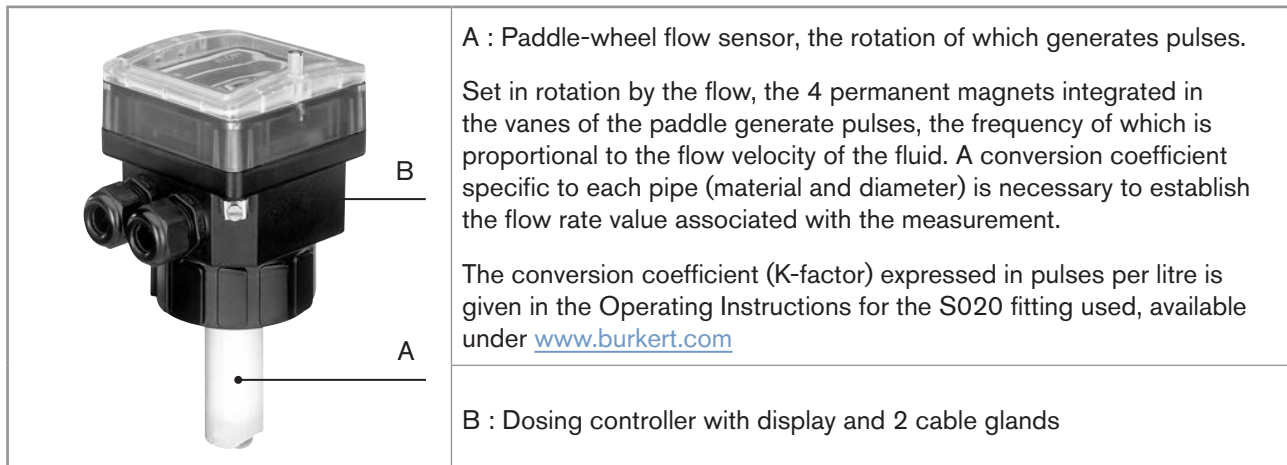

Fig. 1 : Construction of the 8025 Batch in compact version

5.2.2 Construction of the 8025 Batch in panel version

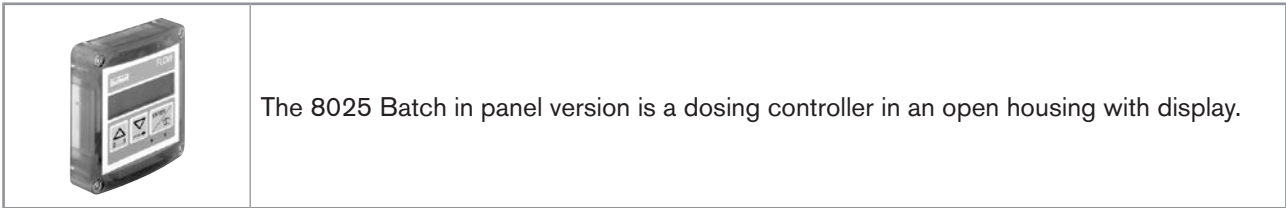

Fig. 2 : Construction of the 8025 Batch in panel version

5.2.3 Construction of the 8025 Batch in wall-mounted version

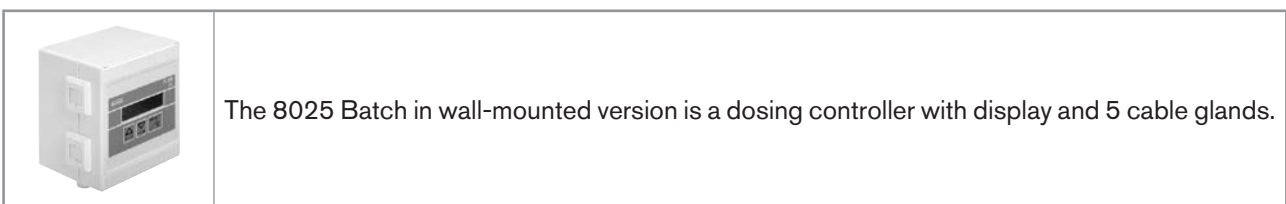

Fig. 3 : Construction of the 8025 Batch in wall-mounted version

5.2.4 Construction of the SE35 Batch

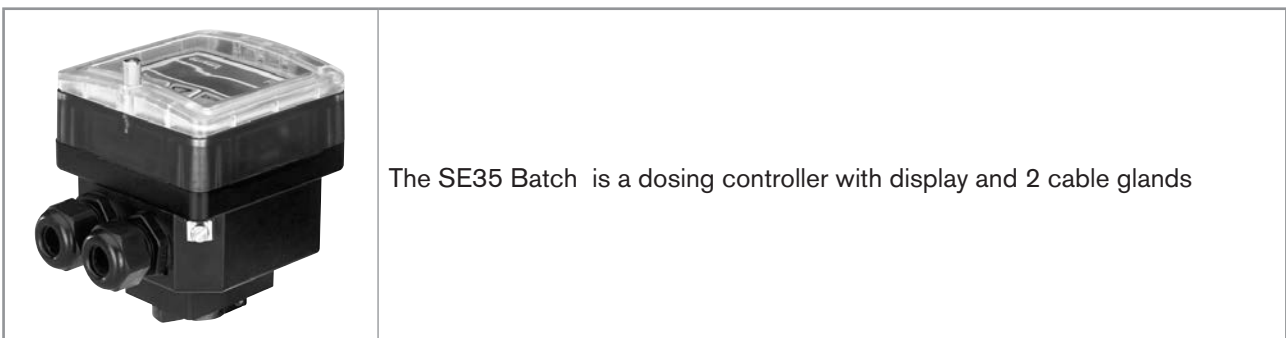

Fig. 4 : Construction of the SE35 Batch

5.2.5 Construction of the 8035 Batch

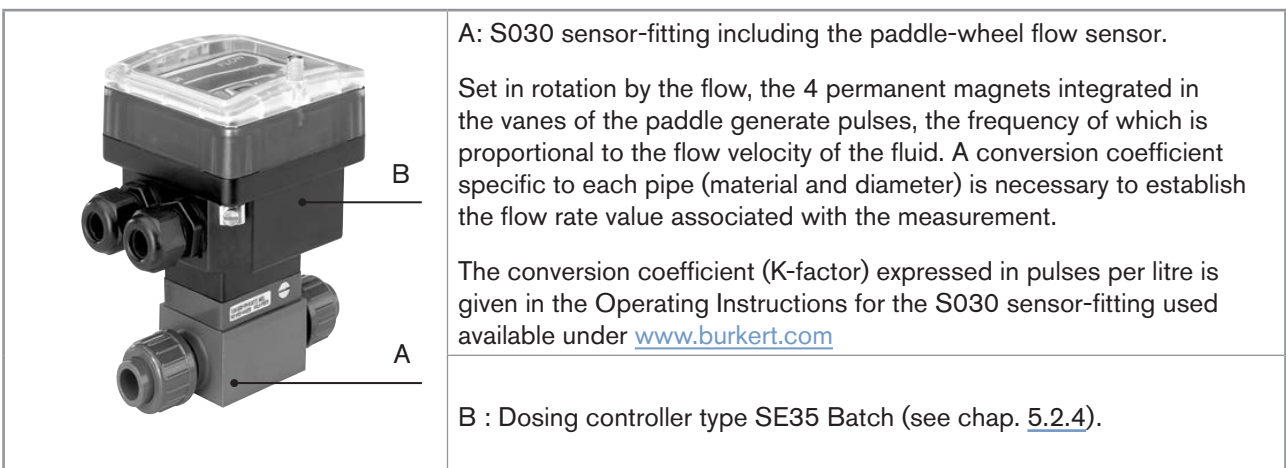

Fig. 5 : Construction of the 8035 Batch

5.2.6 Construction of the SE35 Batch with sensor-fitting S070 or S077

A: S070 or S077 sensor-fitting including the flow sensor with oval gears.

Set in rotation by the flow, the magnets integrated in the oval gears generate pulses, the frequency of which is proportional to the volume of fluid. A conversion coefficient specific to each pipe (material and diameter) is necessary to establish the flow rate value associated with the measurement.

The conversion coefficient (K-factor) expressed in pulses per litre is given in the Operating Instructions for the S070 or S077 sensor-fitting used, available under: www.burkert.com

B : Dosing controller type SE35 Batch (see chap. 5.2.4).

Fig. 6 : Construction of the SE35 Batch with sensor-fitting S070 or S077

5.3 Description of the name plate

	<ol style="list-style-type: none"> 1. Type of the device 2. Sensor specifications 3. Specifications of the transistor outputs DO1 and DO4 4. Power supply and max. current consumption 5. Protection class of the device 6. Manufacturing code
<ol style="list-style-type: none"> 7. Conformity marking 8. Certification 9. Warning: Before using the device, take into account the technical specifications described in these operating instructions 10. Specifications of the relay outputs DO2 and DO3 11. Serial number 12. Order code 	

Fig. 7 : Name plate of the device (example)

MAN 1000199281 EN Version: C Status: RL (released | freigegeben) printed: 22.09.2017

6 TECHNICAL DATA

6.1 Technical data of the dosing controller 8025 Batch in compact version

6.1.1 Conditions of use of a 8025 Batch in compact version

Ambient temperature	
▪ 12...36 V DC version	▪ -10...+60°C
▪ 115/230 V AC version	▪ -10...+50°C
▪ UL and CSA version	▪ 0...+40°C
Air humidity	< 80%, non condensated
Protection rating according to EN 60529	IP65, device wired, cover lid screwed tight and cable glands tightened
Degree of pollution (UL and CSA recognized version)	Degree 2 according to EN 61010 -1
Installation category (UL and CSA recognized version)	Category I according to UL61010-1 - Indoor use
Max. height above sea level	2000 m

6.1.2 Conformity to standards and directives of a 8025 Batch in compact version

The applied standards, which verify conformity with the EU Directives, can be found on the EU Type Examination Certificate and/or the EU Declaration of Conformity (if applicable).

- Pressure: according to article 4§1 of the Pressure Equipment Directive 2014/68/EU, the device can only be used in the following cases (depending on the max. pressure, the DN of the pipe and the fluid):

Type of fluid	Conditions
Fluid group 1, art. 4 §1.c.i	DN ≤ 25
Fluid group 2, art. 4 §1.c.i	DN ≤ 32 or PNxDN ≤ 1000
Fluid group 1, art. 4 §1.c.ii	DN ≤ 25 or PNxDN ≤ 2000
Fluid group 2, art. 4 §1.c.ii	DN ≤ 200 or PN ≤ 10 or PNxDN ≤ 5000

UL-Certification

Finished products with variable key PU01 or PU02 are UL-certified products and comply also with the following standards:

- UL 61010-1
- CAN/CSA-C22.2 n°61010-1

Identification on the device	Certification	Variable key
	UL-recognized	PU01
Measuring Equipment EXXXXXX	UL-listed	PU02

6.1.3 Fluid data of a 8025 Batch in compact version

Type of fluid	neutral or slightly aggressive liquids
Fluid viscosity	max. 300 cSt
Rate of solid particles	max. 1%
Fluid temperature	The fluid temperature may be restricted by the fluid pressure and the material the S020 fitting used is made of (see Fig. 8)
▪ with S020 fitting in PVC	▪ 0...+50°C
▪ with S020 fitting in PP	▪ 0...+80°C
▪ with S020 fitting in PVDF, stainless steel or brass	▪ -15...+80°C
Fluid pressure	PN10 max The fluid pressure may be restricted by the fluid temperature and the material the S020 fitting used is made (see Fig. 8)
Flow rate measurement	
▪ Measurement range	▪ 0,3...10 m/s
▪ Measurement deviation	
- with standard K-factor of the S020 fitting	- ±2.5% of the measured value ¹⁾
- with K-factor determined with a Teach-In procedure	- ±1% of the measured value ¹⁾ (at the value of the Teach-In flow rate)
▪ Linearity	▪ ±0,5% of the full scale (10 m/s)
▪ Repeatability	▪ ±0,4% of the measured value ¹⁾

¹⁾ Determined in the following reference conditions: medium = water, water and ambient temperatures 20 °C, min. upstream and downstream distances respected, appropriate pipe dimensions

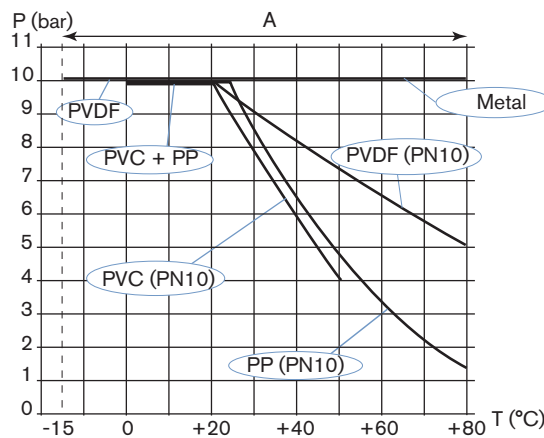

A: Operating range

Fig. 8 : Fluid temperature/pressure dependency curves for the 8025 Batch in compact version, depending on the material the S020 fitting is made of

6.1.4 Material data of a 8025 Batch in compact version

Part	Material
Housing /cover, lid, nut	PC
Frontfoil / Screws	Polyester / Stainless steel
Cable glands	PA
Identification label	Polyester
Wetted parts	
▪ Sensor holder / Paddle-wheel	▪ PVDF
▪ Axis and bearings of the paddle-wheel	▪ Ceramics
▪ Seal	▪ FKM (optional EPDM)
▪ Fitting S020	▪ Refer to the Operating Instructions of the fitting

6.1.5 Dimensions of a 8025 Batch in compact version

→ Please refer to the technical data sheets regarding the dosing controller type 8025 Batch in compact version, available at: www.burkert.com

6.1.6 Electrical data of a 8025 Batch in compact version

12...36 V DC power supply	<ul style="list-style-type: none"> ▪ filtered and regulated ▪ SELV circuit (safety extra low voltage), with a safe energy level ▪ oscillation rate: $\pm 10\%$
Power source (not supplied) for versions supplied with 12..36 V DC	<ul style="list-style-type: none"> ▪ limited power source according to §9.4 of EN 61010-1 standard ▪ or class 2 source according to UL 1310/1585 and EN 60950-1 standards
115/230 V AC power supply	
▪ frequency	▪ 50/60 Hz
▪ supplied voltage	▪ 27 V DC, regulated
▪ Maximum current	▪ 125 mA
▪ integrated protection	▪ 125 mA time-delay fuse
▪ power	▪ 3 VA
Maximum current consumption version 12...36 V DC	100 mA
Maximum current consumption version 115/230 V AC	55 mA
Pulse output (transistor) DO1 and DO4	polarized, potential-free
▪ type	▪ NPN/PNP (wiring dependant)
▪ DO1 function	▪ pulse output (can be configured and parametered)
▪ DO4 function	▪ dosing state (can be configured and parametered)
▪ frequency (f)	▪ 0,6...300 Hz
▪ electrical data	▪ 5...36 V DC, 100 mA max., voltage drop 2,7 V DC at 100 mA
▪ duty cycle	▪ >0,45

▪ protection	▪ galvanically insulated, and protected against over-voltages, polarity reversals and short-circuits
Relay output DO2 and DO3	
▪ operating	▪ hysteresis, adjustable thresholds, normally open
▪ DO2 function	▪ valve 100%, cannot be modified
▪ DO3 function	▪ alarm (can be configured and parametered)
▪ electrical data of the load (non UL recognized devices)	▪ 230 V AC / 3 A or 40 V DC / 3 A (resistive load)
▪ electrical data of the load (UL recognized devices)	▪ max. 30 V AC and 42 V peak / 3 A or max. 60 V DC / 1 A
Digital inputs DI1 to DI4	
▪ commutation threshold V_{on}	▪ 5...36 V DC
▪ commutation threshold V_{off} max.	▪ 2 V DC
▪ min. pulse duration	▪ 100 ms
▪ input impedance	▪ 9,4 k Ω
▪ protection	▪ galvanically isolated, and protected against polarity reversals and voltage spikes

6.2 Technical data of the dosing controller 8025 Batch in panel version

6.2.1 Conditions of use of a 8025 Batch in panel version

Ambient temperature	
▪ non-UL version	▪ -10...+60°C
▪ UL and CSA version	▪ 0...+40°C
Air humidity	< 80%, non condensated
Protection rating according to EN 60529	
▪ front side	▪ IP65, installation completed and closed cabinet
▪ non-front side	▪ IP20 in the closed cabinet
Degree of pollution (UL and CSA recognized version)	Degree 2 according to EN 61010 -1
Installation category (UL and CSA recognized version)	Category I according to UL61010-1 - Indoor use
Max. height above sea level	2000 m



6.2.2 Conformity to standards and directives of a 8025 Batch in panel version

The applied standards, which verify conformity with the EU Directives, can be found on the EU Type Examination Certificate and/or the EU Declaration of Conformity (if applicable).

UL-Certification

Finished products with variable key PU01 or PU02 are UL-certified products and comply also with the following standards:

- UL 61010-1
- CAN/CSA-C22.2 n°61010-1

Identification on the device	Certification	Variable key
	UL-recognized	PU01
 Measuring Equipment EXXXXXX	UL-listed	PU02

6.2.3 Material data of a 8025 Batch in panel version

Part	Material
Housing /cover	PC
Frontfoil / Screws	Polyester / Stainless steel
Cable glands	PA
Identification label	Polyester

6.2.4 Dimensions of a 8025 Batch in panel version

→ Please refer to the technical data sheets regarding the dosing controller type 8025 Batch in panel version, available at: www.burkert.com

6.2.5 Electrical data of a 8025 Batch in panel version

12...36 V DC power supply	<ul style="list-style-type: none"> ▪ filtered and regulated ▪ SELV circuit (safety extra low voltage), with a safe energy level ▪ oscillation rate: $\pm 10\%$
Power source (not supplied) for versions supplied with 12...36 V DC	<ul style="list-style-type: none"> ▪ limited power source according to §9.4 of EN 61010-1 standard ▪ or class 2 source according to UL 1310/1585 and EN 60950-1 standards
Maximum current consumption version 12...36 V DC	70 mA
Pulse output (transistor) DO1 and DO4	polarized, potential-free
<ul style="list-style-type: none"> ▪ type ▪ DO1 function ▪ DO4 function ▪ frequency (f) ▪ electrical data 	<ul style="list-style-type: none"> ▪ NPN/PNP (wiring dependant) ▪ pulse output (can be configured and parametered) ▪ dosing state (can be configured and parametered) ▪ 0,6...2200 Hz ▪ 5...36 V DC, 100 mA max., voltage drop 2,7 V DC at 100 mA
<ul style="list-style-type: none"> ▪ duty cycle - if $0,6 < f < 300$ Hz - if $300 < f < 1500$ Hz - if $1500 < f < 2200$ Hz 	<ul style="list-style-type: none"> - > 0,45 - > 0,4 - < 0,4
<ul style="list-style-type: none"> ▪ protection 	<ul style="list-style-type: none"> ▪ galvanically insulated, and protected against over-voltages, polarity reversals and short-circuits

Relay output DO2 and DO3	
▪ operating	▪ hysteresis, adjustable thresholds, normally open
▪ DO2 function	▪ valve 100%, cannot be modified
▪ DO3 function	▪ alarm (can be configured and parametered)
▪ electrical data of the load (non UL recognized devices)	▪ 230 V AC / 3 A or 40 V DC / 3 A (resistive load)
▪ electrical data of the load (UL recognized devices)	▪ max. 30 V AC and 42 V peak / 3 A or max. 60 V DC / 1 A
Digital inputs DI1 to DI4	
▪ commutation threshold V_{on}	▪ 5...36 V DC
▪ commutation threshold V_{off} max.	▪ 2 V DC
▪ min. pulse duration	▪ 100 ms
▪ input impedance	▪ 9,4 k Ω
▪ protection	▪ galvanically isolated, and protected against polarity reversals and voltage spikes

6.2.6 Specifications of a remote flow sensor connected to a 8025 Batch in panel version

Signal from the remote sensor	
▪ type	▪ pulse, sine-wave (typical sensitivity 50 mV peak-to-peak at 250 Hz), "on/off", or standard voltage 0...5 V DC
▪ frequency	▪ 0,6...2200 Hz, can be parametered
▪ max. voltage	▪ 36 V DC
Input impedance	depends on the position of selector "LOAD" on the electronic board of the 8025 Batch in panel version. See chap. 8.7 and 8.9.
Power supply	
▪ dosing controller supplied with a 12...36 V DC voltage	supplied by the dosing controller depending on the position of selector "SENSOR SUPPLY" of the 8025 Batch in panel version, either: <ul style="list-style-type: none"> ▪ 5 V DC, 30 mA max. ▪ (L+) – 12V: supply voltage (L+) of the dosing controller minus 12 V DC (minus 12,5 V DC max.), 80 mA max. ▪ L+: supply voltage (L+) of the dosing controller (minus 1,5 V DC max.), 140 mA max.

MAN 1000199281 EN Version: C Status: RL (released | freigegeben) printed: 22.09.2017

6.3 Technical data of the dosing controller 8025 Batch in wall-mounted version

6.3.1 Conditions of use of a 8025 Batch in wall-mounted version

Ambient temperature	-10...+60°C
Air humidity	< 80%, non condensated
Protection rating according to EN 60529	IP65, device wired, cable glands tightened, cover lid screwed tight and entry item nuts of the cable glands tightened at a screwing torque of 1.5 Nm.
Degree of pollution (UL and CSA recognized version)	Degree 2 according to EN 61010 -1
Installation category (UL and CSA recognized version)	Category I according to UL61010-1 - Indoor use
Max. height above sea level	2000 m



6.3.2 Conformity to standards and directives of a 8025 Batch in wall-mounted version

The applied standards, which verify conformity with the EU Directives, can be found on the EU Type Examination Certificate and/or the EU Declaration of Conformity (if applicable).

UL-Certification

Finished products with variable key PU01 or PU02 are UL-certified products and comply also with the following standards:

- UL 61010-1
- CAN/CSA-C22.2 n°61010-1

Identification on the device	Certification	Variable key
	UL-recognized	PU01
 Measuring Equipment EXXXXXX	UL-listed	PU02

6.3.3 Material data of a 8025 Batch in wall-mounted version

Part	Material
Housing / Cover	ABS
Frontfoil / Screws	Polyester / Stainless steel
Cable glands	PA
Identification label	Polyester

6.3.4 Dimensions of a 8025 Batch in wall-mounted version

→ Please refer to the technical data sheets regarding the dosing controller type 8025 Batch in wall-mounted version, available at: www.burkert.com

6.3.5 Electrical data of a 8025 Batch in wall-mounted version

12...36 V DC power supply	<ul style="list-style-type: none"> ▪ filtered and regulated ▪ SELV circuit (safety extra low voltage), with a safe energy level ▪ oscillation rate: $\pm 10\%$
Power source (not supplied) for versions supplied with 12...36 V DC	<ul style="list-style-type: none"> ▪ limited power source according to §9.4 of EN 61010-1 standard ▪ or class 2 source according to UL 1310/1585 and EN 60950-1 standards
115/230 V AC power supply	
▪ frequency	▪ 50/60 Hz
▪ supplied voltage	▪ 27 V DC, regulated
▪ Maximum current	▪ 250 mA
▪ integrated protection	▪ 250 mA time-delay fuse
▪ power	▪ 6 VA
Maximum current consumption version 12...36 V DC	70 mA
Maximum current consumption version 115/230 V AC	55 mA
Pulse output (transistor) DO1 and DO4	polarized, potential-free
▪ type	▪ NPN/PNP (wiring dependant)
▪ DO1 function	▪ pulse output (can be configured and parametered)
▪ DO4 function	▪ dosing state (can be configured and parametered)
▪ frequency (f)	▪ 0,6...2200 Hz
▪ electrical data	▪ 5...36 V DC, 100 mA max., voltage drop 2,7 V DC at 100 mA
▪ duty cycle	
- if $0,6 < f < 300$ Hz	- $> 0,45$
- if $300 < f < 1500$ Hz	- $> 0,4$
- if $1500 < f < 2200$ Hz	- $< 0,4$
▪ protection	▪ galvanically insulated, and protected against over-voltages, polarity reversals and short-circuits
Relay output DO2 and DO3	
▪ operating	▪ hysteresis, adjustable thresholds, normally open
▪ DO2 function	▪ valve 100%, cannot be modified
▪ DO3 function	▪ alarm (can be configured and parametered)
▪ electrical data of the load (non UL recognized devices)	▪ 230 V AC / 3 A or 40 V DC / 3 A (resistive load)
▪ electrical data of the load (UL recognized devices)	▪ max. 30 V AC and 42 V peak / 3 A or max. 60 V DC / 1 A

Digital inputs DI1 to DI4	
▪ commutation threshold V_{on}	▪ 5...36 V DC
▪ commutation threshold V_{off} max.	▪ 2 V DC
▪ min. pulse duration	▪ 100 ms
▪ input impedance	▪ 9,4 k Ω
▪ protection	▪ galvanically isolated, and protected against polarity reversals and voltage spikes

6.3.6 Specifications of a remote flow sensor connected to a 8025 Batch in wall-mounted version

Signal from the remote sensor	
▪ type	▪ pulse, sine-wave (typical sensitivity 50 mV peak-to-peak at 250 Hz), "on/off", or standard voltage 0...5 V DC
▪ frequency	▪ 0,6...2200 Hz, can be parametered
▪ max. voltage	▪ 36 V DC
Input impedance	depends on the position of selector "LOAD" on the electronic board of the 8025 Batch in wall-mounted version. See chap. 8.8 and 8.9 .
Power supply	
▪ dosing controller supplied with a 12...36 V DC voltage	supplied by the dosing controller depending on the position of selector "SENSOR SUPPLY" of the 8025 Batch in wall-mounted version, either: <ul style="list-style-type: none"> ▪ 5 V DC, 30 mA max. ▪ (L+) – 12V: supply voltage (L+) of the dosing controller minus 12 V DC (minus 12,5 V DC max.), 80 mA max. ▪ L+: supply voltage (L+) of the dosing controller (minus 1,5 V DC max.), 140 mA max.
dosing controller supplied with a 115/230 V AC voltage	supplied by the dosing controller depending on the position of selector "SENSOR SUPPLY" of the 8025 in wall-mounted version, either: <ul style="list-style-type: none"> ▪ 5 V DC, 30 mA max. ▪ (L+) – 12V: 27 V DC minus 12 V DC (minus 12,5 V DC max.), 80 mA max. ▪ L+: 27 V DC, 80 mA max.

6.4 Technical data of the dosing controller SE35 Batch



The technical data of the flow transmitted dosing controller SE35 Batch can be restricted by the sensor-fitting used.

► Please refer to the Operating Instructions of the concerned sensor-fitting.

6.4.1 Conditions of use of a SE35 Batch

Ambient temperature	
▪ 12...36 V DC version	▪ -10...+60°C
▪ 115/230 V AC version	▪ -10...+50°C
▪ UL and CSA version	▪ 0...+40°C
Air humidity	< 80%, non condensated
Protection rating according to EN 60529	IP65, device wired, cover lid screwed tight and cable glands tightened
Degree of pollution (UL and CSA recognized version)	Degree 2 according to EN 61010 -1
Installation category (UL and CSA recognized version)	Category I according to UL61010-1 - Indoor use
Max. height above sea level	2000 m



6.4.2 Conformity to standards and directives of a SE35 Batch

The applied standards, which verify conformity with the EU Directives, can be found on the EU Type Examination Certificate and/or the EU Declaration of Conformity (if applicable).

UL-Certification

Finished products with variable key PU01 or PU02 are UL-certified products and comply also with the following standards:

- UL 61010-1
- CAN/CSA-C22.2 n°61010-1

Identification on the device	Certification	Variable key
	UL-recognized	PU01
 Measuring Equipment EXXXXXX	UL-listed	PU02

6.4.3 Material data of a SE35 Batch

Part	Material
Housing, cover, lid, nut	PC
Frontfoil / Screws	Polyester / Stainless steel
Cable glands	PA
Identification label	Polyester

6.4.4 Dimensions of a SE35 Batch

→ Please refer to the technical data sheet regarding the dosing controller type SE35 Batch, available at: www.burkert.com

6.4.5 Electrical data of a SE35 Batch

12...36 V DC power supply	<ul style="list-style-type: none"> ▪ filtered and regulated ▪ SELV circuit (safety extra low voltage), with a safe energy level ▪ oscillation rate: $\pm 10\%$
Power source (not supplied) for versions supplied with 12...36 V DC	<ul style="list-style-type: none"> ▪ limited power source according to §9.4 of EN 61010-1 standard ▪ or class 2 source according to UL 1310/1585 and EN 60950-1 standards
115/230 V AC power supply	
▪ frequency	▪ 50/60 Hz
▪ supplied voltage	▪ 27 V DC, regulated
▪ Maximum current	▪ 125 mA
▪ integrated protection	▪ 125 mA time-delay fuse
▪ power	▪ 3 VA
Maximum current consumption version 12...36 V DC	100 mA
Maximum current consumption version 115/230 V AC	55 mA
Pulse output (transistor) DO1 and DO4	polarized, potential-free
▪ type	▪ NPN/PNP (wiring dependant)
▪ DO1 function	▪ pulse output (can be configured and parametered)
▪ DO4 function	▪ dosing state (can be configured and parametered)
▪ frequency (f)	▪ 0,6...300 Hz
▪ electrical data	▪ 5...36 V DC, 100 mA max., voltage drop 2,7 V DC at 100 mA
▪ duty cycle	▪ >0,45
▪ protection	▪ galvanically insulated, and protected against over-voltages, polarity reversals and short-circuits
Relay output DO2 and DO3	
▪ operating	▪ hysteresis, adjustable thresholds, normally open
▪ DO2 function	▪ valve 100%, cannot be modified
▪ DO3 function	▪ alarm (can be configured and parametered)
▪ electrical data of the load (non UL recognized devices)	▪ 230 V AC / 3 A or 40 V DC / 3 A (resistive load)
▪ electrical data of the load (UL recognized devices)	▪ max. 30 V AC and 42 V peak / 3 A or max. 60 V DC / 1 A

Digital inputs DI1 to DI4	
▪ commutation threshold V_{on}	▪ 5...36 V DC
▪ commutation threshold V_{off} max.	▪ 2 V DC
▪ min. pulse duration	▪ 100 ms
▪ input impedance	▪ 9,4 k Ω
▪ protection	▪ galvanically isolated, and protected against polarity reversals and voltage spikes

6.5 Technical data of the dosing controller 8035 Batch

The dosing controller 8035 Batch comprises an S030 sensor-fitting including the paddle-wheel flow sensor and a dosing controller type SE35 Batch (see chap. 5.2.5).



The technical data of the dosing controller 8035 Batch may be restricted by the S030 sensor-fitting used.

► Please refer to the Operating Instructions of the concerned sensor-fitting S030.

6.5.1 Conditions of use of a 8035 Batch

Ambient temperature	
▪ 12...36 V DC version	▪ -10...+60°C
▪ 115/230 V AC version	▪ -10...+50°C
▪ UL and CSA version	▪ 0...+40°C
Air humidity	< 80%, non condensated
Protection rating according to EN 60529	IP65, device wired, cover lid screwed tight and cable glands tightened
Degree of pollution (UL and CSA recognized version)	Degree 2 according to EN 61010 -1
Installation category (UL and CSA recognized version)	Category I according to UL61010-1 - Indoor use
Max. height above sea level	2000 m

6.5.2 Conformity to standards and directives of a 8035 Batch

The applied standards, which verify conformity with the EU Directives, can be found on the EU Type Examination Certificate and/or the EU Declaration of Conformity (if applicable).



- Pressure: according to article 4§1 of the Pressure Equipment Directive 2014/68/EU, the device can only be used in the following cases (depending on the max. pressure, the DN of the pipe and the fluid):

Type of fluid	Conditions
Fluid group 1, art. 4 §1.c.i	DN ≤ 25
Fluid group 2, art. 4 §1.c.i	DN ≤ 32 or PNxDN ≤ 1000
Fluid group 1, art. 4 §1.c.ii	DN ≤ 25 or PNxDN ≤ 2000
Fluid group 2, art. 4 §1.c.ii	DN ≤ 200 or PN ≤ 10 or PNxDN ≤ 5000

UL-Certification

Finished products with variable key PU01 or PU02 are UL-certified products and comply also with the following standards:

- UL 61010-1
- CAN/CSA-C22.2 n°61010-1

Identification on the device	Certification	Variable key
	UL-recognized	PU01
 Measuring Equipment EXXXXXX	UL-listed	PU02

6.5.3 Fluid data of a 8035 Batch

Type of fluid	neutral or slightly aggressive liquids
Fluid viscosity	max. 300 cSt
Rate of solid particles	max. 1%
Fluid temperature	The fluid temperature may be restricted by the fluid pressure and the material the S030 sensor-fitting used is made of (see Fig. 9)
▪ with S030 sensor-fitting in PVC	▪ 0...+50°C
▪ with S030 sensor-fitting in PP	▪ 0...+80°C
▪ with S030 sensor-fitting in PVDF, stainless steel or brass	▪ -15...+100°C
Fluid pressure	The fluid pressure may be restricted by the fluid temperature and the material the S030 sensor-fitting used is made (see Fig. 9)
▪ with sensor-fitting S030 in plastic	PN10
▪ with sensor-fitting S030 in metal	PN16 (PN40 on request)
Flow rate measurement	
▪ Measurement range	▪ 0,3...10 m/s
▪ Measurement deviation	
- with standard K-factor of the S020 fitting	- ±2.5% of the measured value ¹⁾
- with K-factor determined with a Teach-In procedure	- ±1% of the measured value ¹⁾ (at the value of the Teach-In flow rate)
▪ Linearity	▪ ±0,5% of the full scale (10 m/s)
▪ Repeatability	▪ ±0,4% of the measured value ¹⁾

¹⁾ Determined in the following reference conditions: medium = water, water and ambient temperatures 20 °C, min. upstream and downstream distances respected, appropriate pipe dimensions

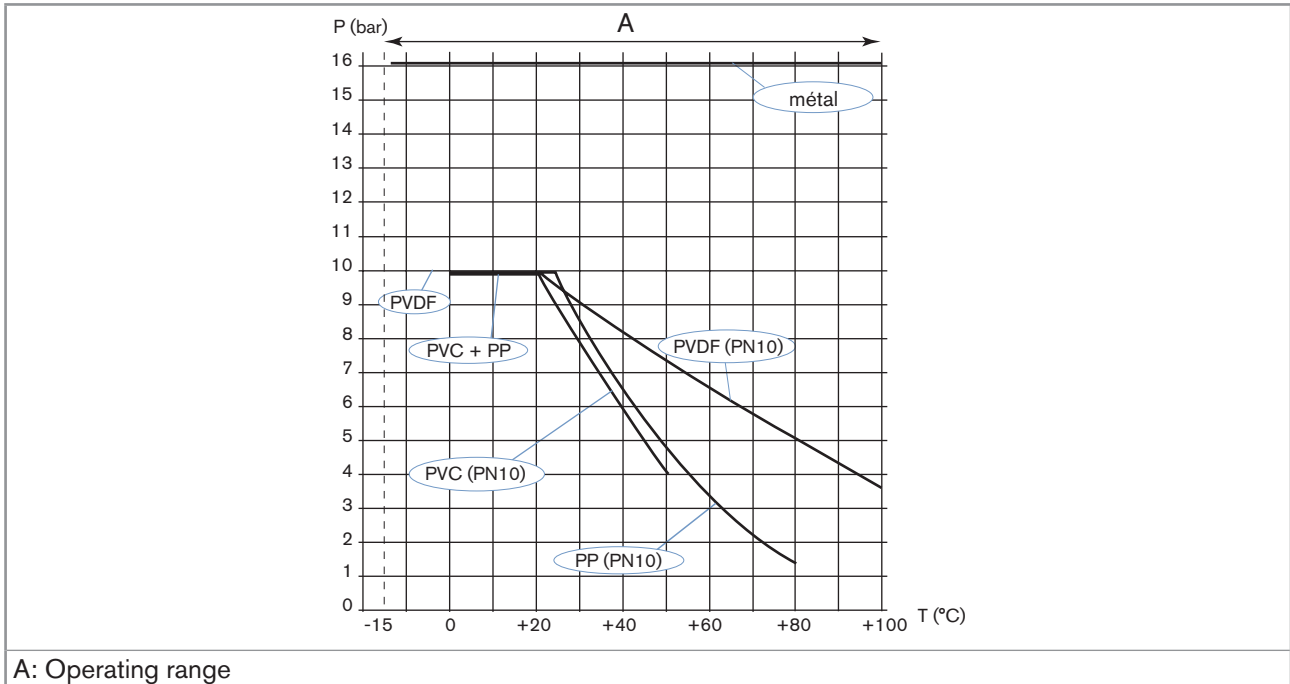

Fig. 9 : Fluid temperature/pressure dependency curves for a dosing controller type 8035 Batch, depending on the material the S030 sensor-fitting is made of

6.5.4 Material data of a 8035 Batch

Part	Material
Housing, cover, lid, nut	PC
Frontfoil / Screws	Polyester / Stainless steel
Cable glands	PA
Identification label	Polyester
Wetted parts	
▪ Sensor holder / Paddle-wheel	▪ PVDF
▪ Axis and bearings of the paddle-wheel	▪ Ceramics
▪ Seal	▪ FKM (optional EPDM)
▪ Sensor-fitting S030	▪ Refer to the Operating Instructions of the sensor-fitting

6.5.5 Dimensions of a 8035 Batch

→ Please refer to the technical data sheets regarding the dosing controller type 8035 Batch, available at: www.burkert.com

6.5.6 Electrical data of a 8035 Batch

→ Please refer to the electrical data of the dosing controller type SE35 Batch, chap. [6.4.5, page 26](#).

6.6 Technical data of the dosing controller SE35 Batch associated with a sensor-fitting S070 or S077



The technical data of the dosing controller SE35 Batch may be restricted by the S070 or S077 sensor-fitting used.

- ▶ Please refer to the Operating Instructions of the concerned sensor-fitting S070 or S077.

6.6.1 Conditions of use of a SE35 Batch with a S070 or a S077

Ambient temperature	
▪ 12...36 V DC version	▪ -10...+60°C
▪ 115/230 V AC version	▪ -10...+50°C
▪ UL and CSA version	▪ 0...+40°C
Air humidity	< 80%, non condensated
Protection rating according to EN 60529	IP65, device wired, cover lid screwed tight and cable glands tightened
Degree of pollution (UL and CSA recognized version)	Degree 2 according to EN 61010 -1
Installation category (UL and CSA recognized version)	Category I according to UL61010-1 - Indoor use
Max. height above sea level	2000 m

6.6.2 Conformity to standards and directives of a SE35 Batch with a S070 or a S077

The applied standards, which verify conformity with the EU Directives, can be found on the EU Type Examination Certificate and/or the EU Declaration of Conformity (if applicable).

- Pressure: according to article 4§1 of the Pressure Equipment Directive 2014/68/EU, the device can only be used in the following cases (depending on the max. pressure, the DN of the pipe and the fluid):

Type of fluid	Conditions
Fluid group 1, art. 4 §1.c.i	Forbidden
Fluid group 2, art. 4 §1.c.i	DN ≤ 32 or PNxDN ≤ 1000
Fluid group 1, art. 4 §1.c.ii	DN ≤ 25 or PNxDN ≤ 2000
Fluid group 2, art. 4 §1.c.ii	DN ≤ 200 or PN ≤ 10 or PNxDN ≤ 5000

UL-Certification

Finished products with variable key PU01 or PU02 are UL-certified products and comply also with the following standards:

- UL 61010-1
- CAN/CSA-C22.2 n°61010-1

Identification on the device	Certification	Variable key
	UL-recognized	PU01
Measuring Equipment EXXXXXX	UL-listed	PU02

6.6.3 Fluid data of a SE35 Batch with a S070 or a S077

Type of fluid	Please refer to the Operating Instructions of the concerned sensor-fitting S070 or S077																
Fluid temperature	The fluid temperature may be restricted by the fluid pressure and the material the S070 or S077 sensor-fitting used is made of <ul style="list-style-type: none"> ▪ Please refer to the Operating Instructions delivered with the sensor-fitting S070 or S077 or to the concerned technical datasheets 																
Fluid pressure	The fluid pressure may be restricted by the fluid temperature and the material the S070 or S077 sensor-fitting used is made of <ul style="list-style-type: none"> ▪ Please refer to the Operating Instructions delivered with the sensor-fitting S070 or S077 or to the concerned technical datasheets 																
Flow rate measurement																	
<ul style="list-style-type: none"> ▪ Measurement range <table border="0" style="width: 100%;"> <tbody> <tr> <td style="width: 50%;">- viscosity > 5 mPa.s</td> <td>- S070 : 2...1200 l/min</td> </tr> <tr> <td></td> <td>- S077 : 2...1200 l/min</td> </tr> <tr> <td>- viscosity < 5 mPa.s</td> <td>- S070 : 3...616 l/min</td> </tr> <tr> <td></td> <td>- S077 : 3...616 l/min</td> </tr> </tbody> </table> ▪ Measurement deviation <table border="0" style="width: 100%;"> <tbody> <tr> <td style="width: 50%;">- with standard K-factor of the sensor-fitting</td> <td>- S070 : ±0,5% of the measured value ¹⁾</td> </tr> <tr> <td></td> <td>- S077 : ±1% of the measured value ¹⁾</td> </tr> <tr> <td>- with K-factor determined with a teach-in procedure</td> <td>- S070 : ±0,5% of the measured value ¹⁾ (at the value of the teach-in flow rate)</td> </tr> <tr> <td></td> <td>- S077 : ±0,5% of the measured value ¹⁾ (at the value of the teach-in flow rate)</td> </tr> </tbody> </table> ▪ Repeatability <ul style="list-style-type: none"> ▪ ±0,03% of the measured value ¹⁾ 		- viscosity > 5 mPa.s	- S070 : 2...1200 l/min		- S077 : 2...1200 l/min	- viscosity < 5 mPa.s	- S070 : 3...616 l/min		- S077 : 3...616 l/min	- with standard K-factor of the sensor-fitting	- S070 : ±0,5% of the measured value ¹⁾		- S077 : ±1% of the measured value ¹⁾	- with K-factor determined with a teach-in procedure	- S070 : ±0,5% of the measured value ¹⁾ (at the value of the teach-in flow rate)		- S077 : ±0,5% of the measured value ¹⁾ (at the value of the teach-in flow rate)
- viscosity > 5 mPa.s	- S070 : 2...1200 l/min																
	- S077 : 2...1200 l/min																
- viscosity < 5 mPa.s	- S070 : 3...616 l/min																
	- S077 : 3...616 l/min																
- with standard K-factor of the sensor-fitting	- S070 : ±0,5% of the measured value ¹⁾																
	- S077 : ±1% of the measured value ¹⁾																
- with K-factor determined with a teach-in procedure	- S070 : ±0,5% of the measured value ¹⁾ (at the value of the teach-in flow rate)																
	- S077 : ±0,5% of the measured value ¹⁾ (at the value of the teach-in flow rate)																

¹⁾ Determined in the following reference conditions: medium = water, water and ambient temperatures 20 °C, min. upstream and downstream distances respected, appropriate pipe dimensions

6.6.4 Material data of a SE35 Batch with a S070 or a S077

Part	Material
Housing, cover, lid, nut	PC
Frontfoil / Screws	Polyester / Stainless steel
Cable glands	PA
Identification label	Polyester
Wetted parts	
<ul style="list-style-type: none"> ▪ Sensor-fitting S070 	<ul style="list-style-type: none"> ▪ Refer to the Operating Instructions of the concerned sensor-fitting

6.6.5 Dimensions of a SE35 Batch with a S070 or a S077

→ Please refer to the technical data sheets regarding the dosing controller type SE35 Batch and the sensor-fittings type S070 and S077 , available at: www.burkert.com

6.6.6 Electrical data of a SE35 Batch with a S070 or a S077

→ Please refer to the electrical data of the dosing controller type SE35 Batch, chap. [6.4.5](#), page 26.

7 FLUID INSTALLATION

7.1 Safety instructions



DANGER

Danger due to electrical voltage.

- ▶ If a 12...36 V DC powered version is installed either in a wet environment or outdoors, all the electrical voltages must be of max. 35 V DC.
- ▶ Disconnect the electrical power for all the conductors and isolate it before carrying out work on the system.
- ▶ All equipment connected to the wall-mounted or panel version of the flow transmitter 8025 must be double insulated in relation to the mains in accordance with IEC standard 61010-1:2010.
- ▶ Observe all applicable accident protection and safety regulations for electrical equipment.

Risk of injury due to high pressure in the installation.

- ▶ Stop the circulation of fluid, cut off the pressure and drain the pipe before loosening the process connections.
- ▶ Observe the fluid temperature/pressure dependency depending on the fitting used.

Risk of injury due to high fluid temperatures.

- ▶ Use safety gloves to handle the device.
- ▶ Stop the circulation of fluid and drain the pipe before loosening the process connections.

Risk of injury due to the nature of the fluid.

- ▶ Respect the prevailing regulations on accident prevention and safety relating to the use of aggressive fluids.



WARNING

Risk of injury due to non-conforming installation.

- ▶ The fluid and electrical installation can only be carried out by qualified and skilled staff with the appropriate tools.
- ▶ Observe mounting instructions of the fitting or sensor-fitting.
- ▶ Take appropriate measures to avoid unintentional activation of the installation.

Risk of injury if the fluid pressure/temperature dependency is not respected.

- ▶ Take account of fluid temperature-pressure dependency according to the nature of the materials the fitting is made of (see the technical data and the operating instructions of the fitting used).
- ▶ Comply with the Pressure Equipment Directive 2014/68/EU.



Protect this device against electromagnetic interference, ultraviolet rays and, when installed outdoors, the effects of the climatic conditions.

7.2 Installation of the dosing controller type 8025 Batch in compact version

The dosing controller 8025 Batch is inserted into an S020 fitting mounted on the pipes:

1. Install the S020 fitting on the pipes,
2. Install the 8025 Batch in compact version into the S020 fitting,
3. Finalise the installation of the 8025 Batch in compact version.

7.2.1 Install the S020 fitting on the pipes

→ Select an S020 fitting suitable for the speed of the fluid in the pipes



To select a fitting, refer to the calculation tables on the technical data sheet for the relevant fitting.

→ Choose a position for the fitting according to the design of the pipes, in such a way that:

- the upstream and downstream distances are respected according to the design of the pipes, see [Fig. 10](#) and norm EN ISO 5167-1,
- the pipes are always filled to the level of the sensor (see [Fig. 11](#)),
- when mounted vertically, the flow direction of the fluid is upwards (see [Fig. 11](#)),
- air bubbles do not form around the sensor (see [Fig. 11](#)).

→ If necessary, use a flow conditioner to improve measurement precision,

→ Install the fitting on the pipes according to the instructions in the relevant Operating Instructions.

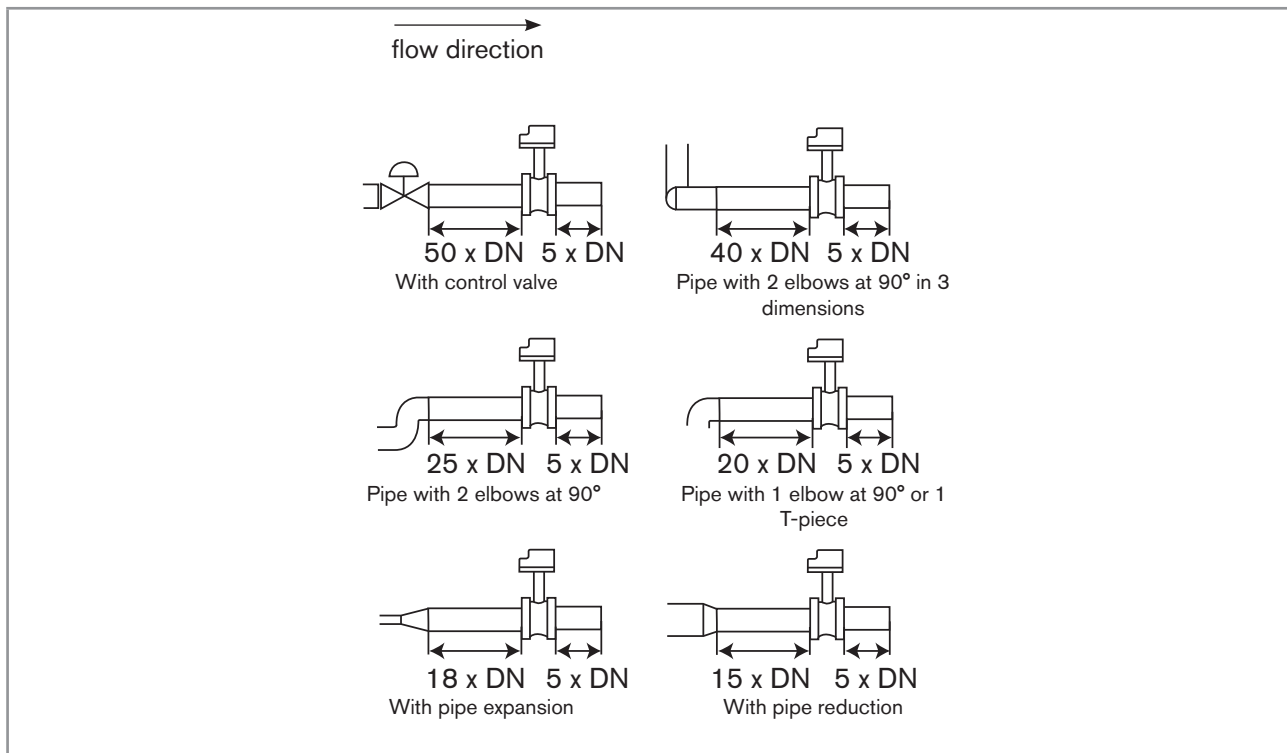

Fig. 10 : Upstream and downstream distances depending on the design of the pipes.

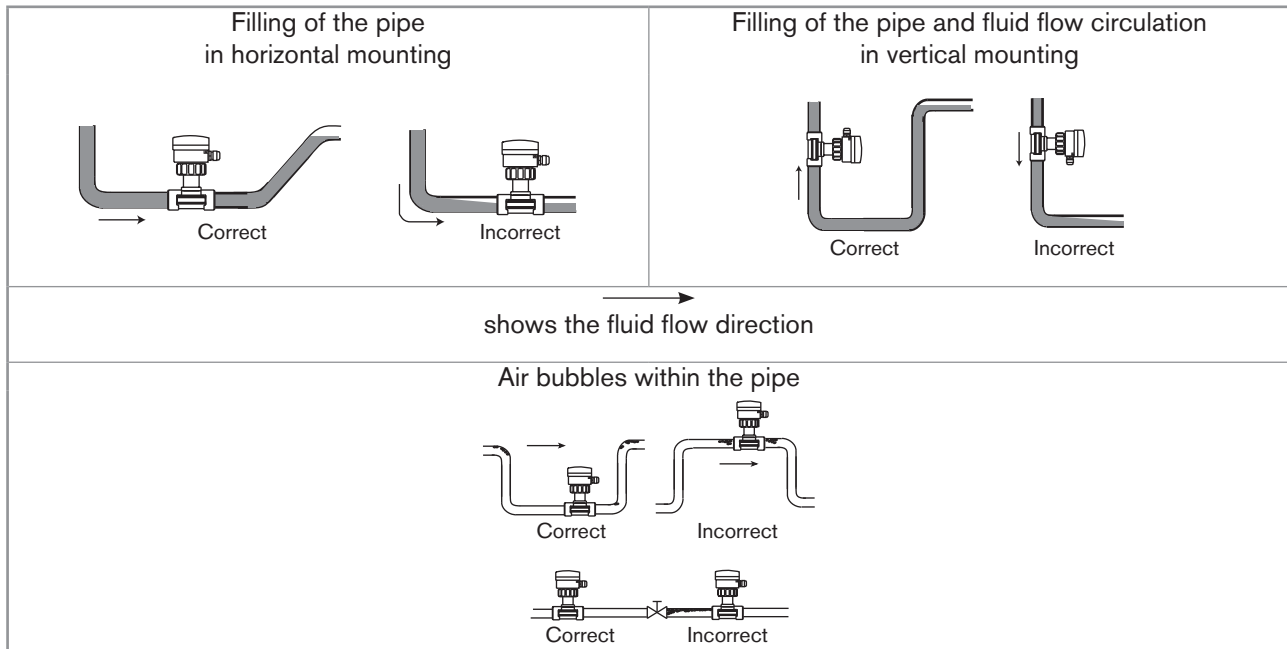

Fig. 11 : Filling of the pipe, flow direction of the fluid, Vertical mounting Air bubbles within the pipe

7.2.2 Install the 8025 Batch in compact version into the S020 fitting

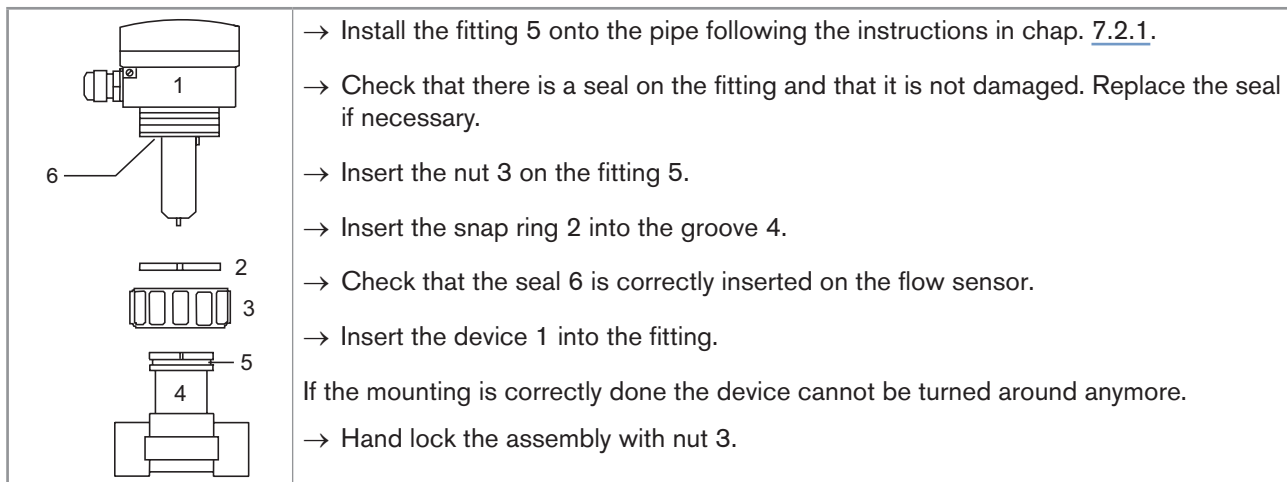

Fig. 12 : Installation of a 8025 Batch in compact version into an S020 fitting

7.2.3 Finalise the installation of the 8025 Batch in compact version.

- Wire the device and switch it on (see chap. 8).
- Set the K-factor or determine it with Teach-In (see chap. 10.7.3 or 10.7.4).

7.3 Installation of the dosing controller 8035 Batch

The dosing controller type 8035 Batch comprises a dosing controller type SE35 Batch and a sensor-fitting type S030. The dosing controller SE35 Batch is assembled on the sensor-fitting S030 by a quarter-turn rotation system:

1. Install the S030 sensor-fitting on the pipes,
2. Install the dosing controller SE35 Batch on the sensor-fitting S030,
3. Finalise the installation of the 8035 Batch.

7.3.1 Install the S030 sensor-fitting on the pipes

→ Select a sensor-fitting S020 suitable for the speed of the fluid in the pipes



To select a sensor-fitting, refer to the calculation tables on the technical data sheet for the relevant sensor-fitting.

→ Choose a position for the sensor-fitting according to the design of the pipes, in such a way that:

- the upstream and downstream distances are respected according to the design of the pipes, see [Fig. 10](#), chap. [7.2.1](#) and norm EN ISO 5167-1,
- the pipes are always filled to the level of the sensor (see [Fig. 11](#), chap. [7.2.1](#)),
- when mounted vertically, the flow direction of the fluid is upwards (see [Fig. 11](#), chap. [7.2.1](#)),
- air bubbles do not form around the sensor-fitting (see [Fig. 11](#), chap. [7.2.1](#)).

→ If necessary, use a flow conditioner to improve measurement precision,

→ Install the sensor-fitting on the pipes according to the instructions in the relevant Operating Instructions.

7.3.2 Install the dosing controller SE35 Batch on the sensor-fitting S030

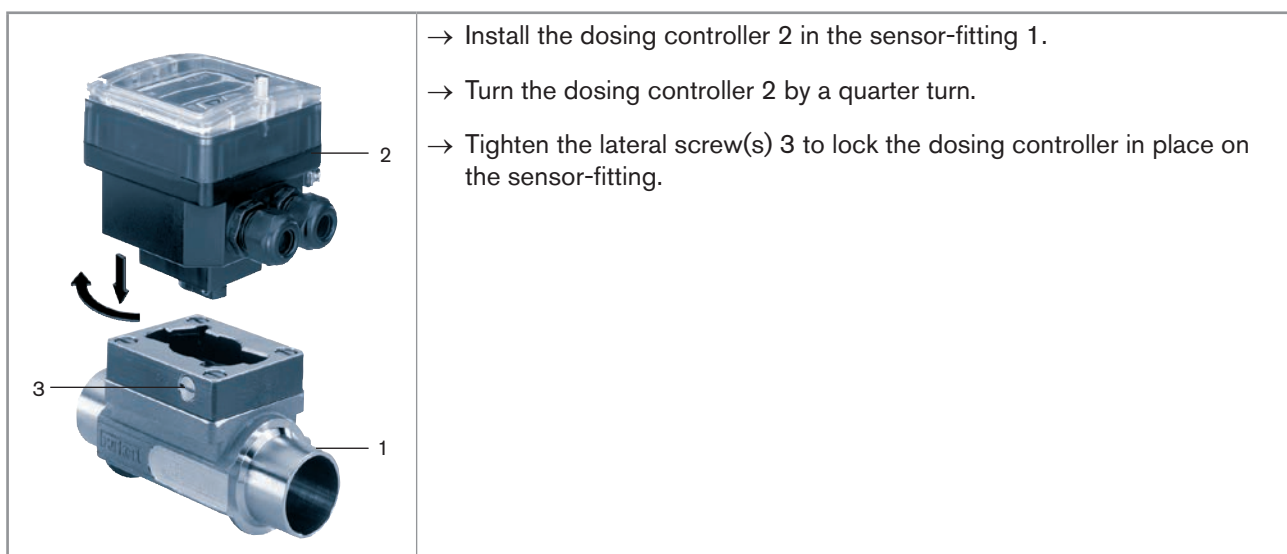

Fig. 13 : Installation of the dosing controller SE35 Batch on the sensor-fitting S030

7.3.3 Finalise the installation of the 8035 Batch

- Wire the device and switch it on (see chap. 8).
- Set the K-factor or determine it with Teach-In (see chap. [10.7.3](#) or [10.7.4](#)).

7.4 Installation of the dosing controller SE35 Batch on the sensor-fitting S070 or S077

The dosing controller SE35 Batch is installed on the pipes using the sensor-fitting S070 or S077. The dosing controller SE35 Batch is assembled on the sensor-fitting S070 or S077 by a quarter-turn system:

1. Install the sensor-fitting S070 or S077 on the pipes,
2. Install the dosing controller SE35 Batch on the sensor-fitting S070 or S077,
3. Finalise the installation.

7.4.1 Install the sensor-fitting S070 or S077 on the pipes

- Select a sensor-fitting S070 or S077 suitable for the viscosity of the fluid.



To select a sensor-fitting, refer to the technical data sheet for the relevant sensor-fitting.



ATTENTION

Risk of damage when installing the sensor-fitting.

- ▶ Follow the installation instructions given in the Operating Instructions for the sensor-fitting.

- Install the sensor-fitting S070 or S077 on the pipes in such a way that:

- the axles of the oval gears are set horizontally, as shown in [Fig. 14](#),
- the installation instructions given in the Operating Instructions for the relevant sensor-fitting are respected.

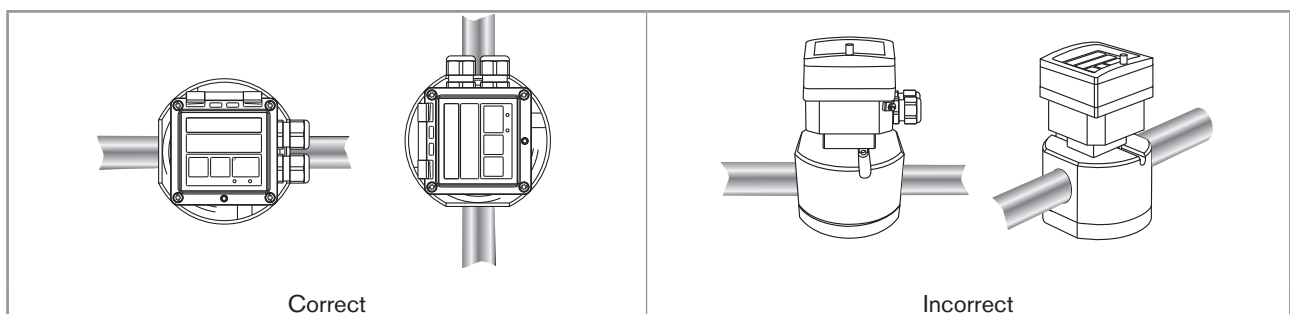

Fig. 14 : The axle of the oval gears must be horizontal

7.4.2 Install the dosing controller SE35 Batch on the sensor-fitting S070 or S077

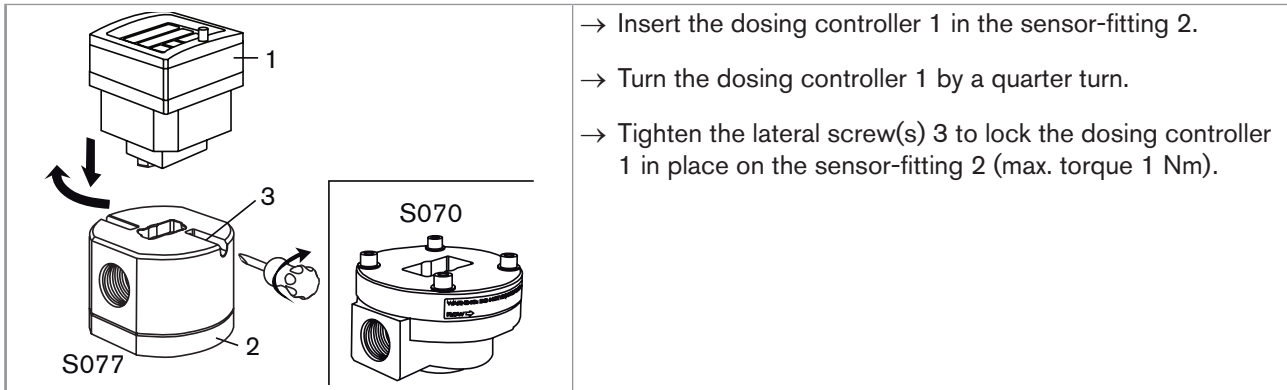

Fig. 15 : Installation of the dosing controller SE35 Batch on the sensor-fitting S070 or S077

7.4.3 Finalise the installation

- Wire the device and switch it on (see chap. 8).
- Set the K-factor or determine it with Teach-In (see chap. 10.7.3 or 10.7.4).

7.5 Installation of the dosing controller 8025 Batch in panel version



Install the 8025 Batch in panel version in a cabinet with a protection class at least IP54 to ensure a degree of pollution 2 inside the cabinet.

- Respect the dimensions indicated in Fig. 16 to cut the opening in the cabinet door.

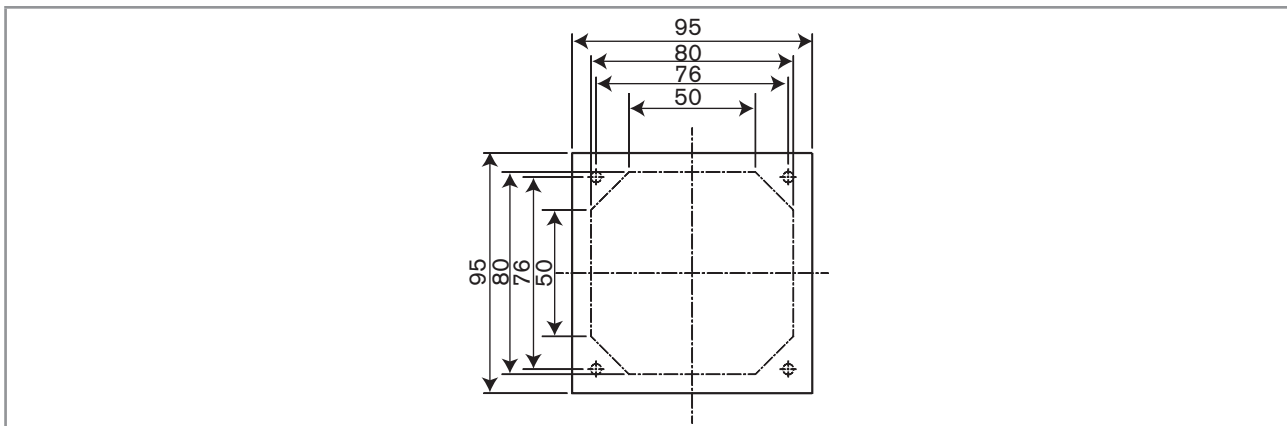

Fig. 16 : Dimensions [mm] of the electrical cabinet frontage cutting plan

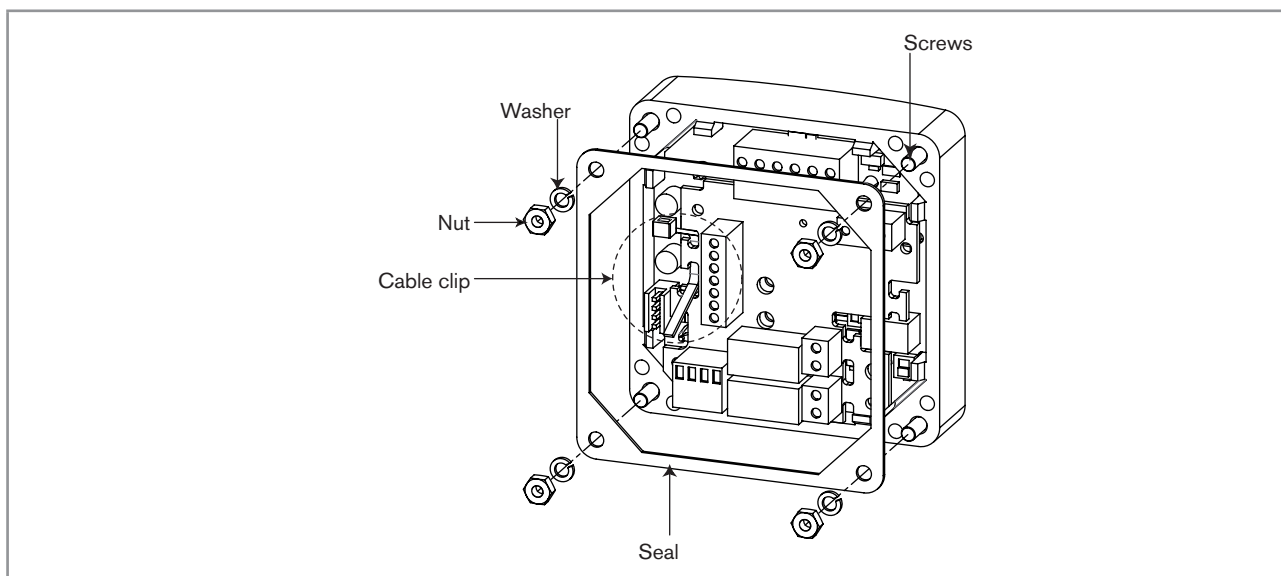

Fig. 17 : Installation of the 8025 Batch in panel version

- Insert the 4 screws in the housing (from the front). If the cabinet door is too thick use the 4 supplied M4*25 screws.
- Insert the seal on the external threads of the 4 screws (rear of the housing).
- Put the assembly on the cutout, electronics turned to the inside of the cabinet.
- Put the 4 washers on the 4 screws.
- Put a nut on each of the 4 screws and tighten the nuts to secure the device to the cabinet.
- Wire the device according to the instructions in chap. [8.7](#).
- Set the K-factor or determine it with Teach-In (see chap. [10.7.3](#) or [10.7.4](#)).

7.6 Installation of the dosing controller 8025 Batch in wall-mounted version

NOTE

Risk of material damage if the cable glands are not tightly screwed on the housing

- ▶ Before installing the wall-mounted housing on its support, tighten the nuts of the entry item of the cables glands at a torque of 1.5 Nm.

The device in a wall-mounted version has 4 holes in the bottom of the housing.

→ Remove the blanking strips covering the screws.

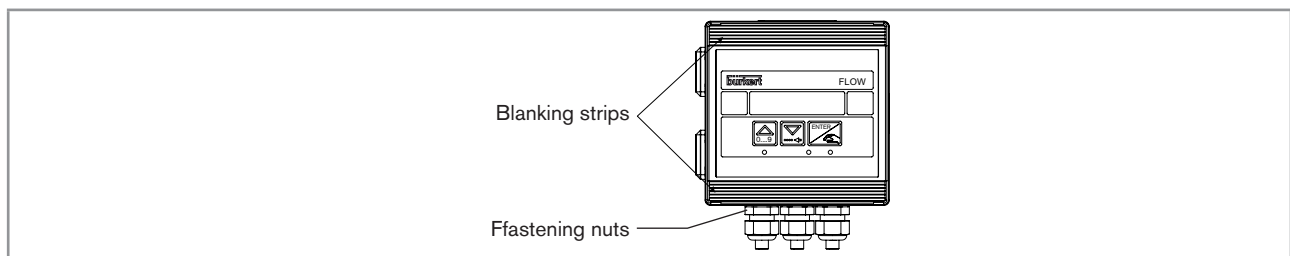

Fig. 18 : Location of the fastening nuts and the blanking strips

→ Loosen the 4 screws and open the cover to get access to the holes [1].

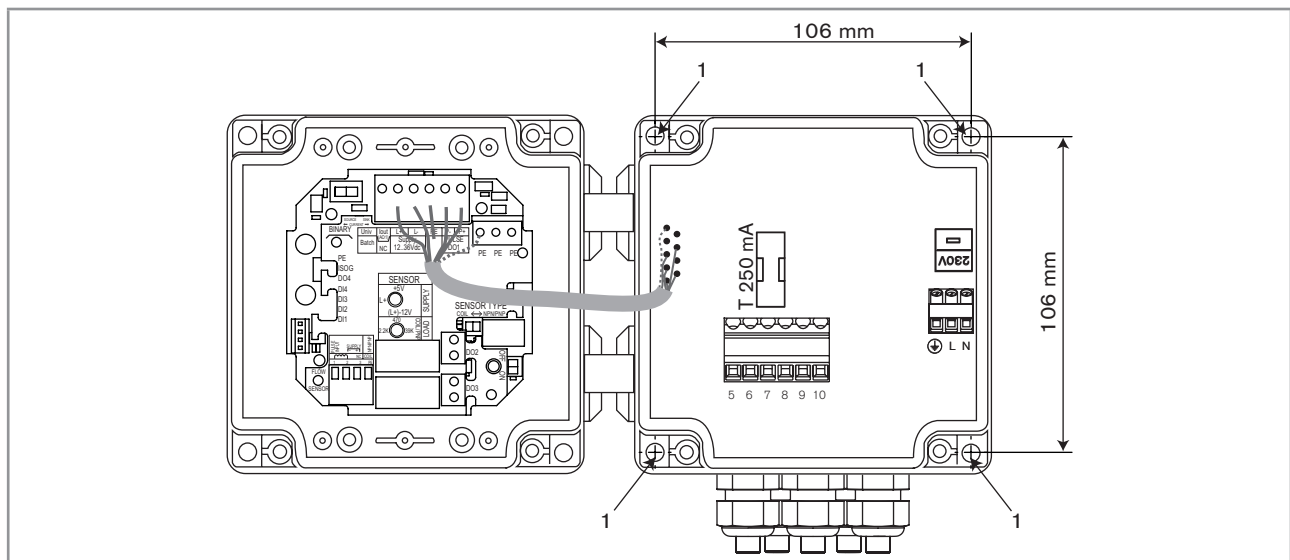

Fig. 19 : Installation of the dosing controller 8025 Batch in wall-mounted version

- Secure the housing to the support respecting the dimensions indicated in [Fig. 19](#).
- Wire according to the instructions in chap. [8.8](#).
- Close the housing and tighten the 4 screws of the cover.
- Set the K-factor or determine it with Teach-In (see chap. [10.7.3](#) or [10.7.4](#)).

8 ELECTRICAL INSTALLATION AND WIRING

8.1 Safety instructions



DANGER

Danger due to electrical voltage.

- ▶ If a 12...36 V DC powered version is installed either in a wet environment or outdoors, all the electrical voltages must be of max. 35 V DC.
- ▶ Disconnect the electrical power for all the conductors and isolate it before carrying out work on the system.
- ▶ All equipment connected to the wall-mounted or panel version of the flow transmitter 8025 must be double insulated in relation to the mains in accordance with IEC standard 61010-1:2010.
- ▶ Observe all applicable accident protection and safety regulations for electrical equipment.

Risk of injury due to high pressure in the installation.

- ▶ Stop the circulation of fluid, cut off the pressure and drain the pipe before loosening the process connections.
- ▶ Observe the fluid temperature/pressure dependency depending on the fitting used.

Risk of injury due to high fluid temperatures.

- ▶ Use safety gloves to handle the device.
- ▶ Stop the circulation of fluid and drain the pipe before loosening the process connections.

Risk of injury due to the nature of the fluid.

- ▶ Respect the prevailing regulations on accident prevention and safety relating to the use of aggressive fluids.



WARNING

Risk of injury due to non-conforming installation.

- ▶ The electrical and fluid installation can only be carried out by qualified and skilled staff with the appropriate tools.
- ▶ Install appropriate safety devices (correctly rated fuse and/or circuit-breaker).
- ▶ Install the circuit breaker or switch in a place which is easy to reach.
- ▶ Identify the circuit breaker or switch as the device's electrical power cut-off system.
- ▶ It is imperative that devices be used that provide adequate protection against overloads. For the versions powered at 115/230 V AC, insert the device protecting against overcurrents in the live conductor (L) and in the neutral conductor (N).
- ▶ Do not power a device, version 12...36 V DC, with an alternating voltage or with a direct voltage in excess of 36 V DC.
- ▶ Do not power a device, version 115/230 V AC, with a direct voltage or with an alternating voltage in excess of 230 V AC.
- ▶ Observe the standard NF C 15-100 / IEC 60364.

 **WARNING**

Risk of injury due to unintentional switch on of power supply or uncontrolled restarting of the installation.

- ▶ Take appropriate measures to avoid unintentional activation of the installation.
- ▶ Guarantee a set or controlled restarting of the process subsequent to any intervention on the device.



- Use a filtered and regulated 12...36 V DC power supply. The circuit has to be safety extra low voltage (SELV), with a safe energy level.
- Make sure the installation is equipotential. See chap. 8.3.
- Do not install the cables near high voltage or high frequency cables; if a combined installation cannot be avoided, a minimum space of 30 cm should be respected.
- Protect the device power supply by means of a 300 mA fuse and a switch.
- Protect the power supply of each transistor output by means of a 125 mA fuse.
- Protect the relays by means of a max. 3 A fuse and a circuit breaker (depending on the process).
- Do not apply both a dangerous voltage and a safety extra-low voltage to the relays.



Insert the supplied stopper gaskets into the unused cable glands to ensure the tightness of the device.

8.2 Specifications of the connection cables

8.2.1 Dosing controller 8025 Batch in compact version, 8035 Batch and SE35 Batch

The electrical connection is done via terminal blocks and via two M20x1,5 cable glands.

Specifications of cables and conductors	Recommended values
▪ Cable type	▪ Shielded (not supplied)
▪ Cross section of wires	▪ 0,2...1,5 mm ²
▪ Diameter of each cable if only one cable is used per cable gland	▪ 6...12 mm
▪ Diameter of each cable if two cables are used per cable gland	▪ 4 mm, with the supplied multi-way seal
▪ Length	▪ max. 50 m
▪ Operating temperature	▪ min. 80°C (min. 90°C for UL recognized version)

8.2.2 Dosing controller 8025 Batch in panel version

The electrical connection is done directly on the terminal blocks of the electronics.

Specifications of cables and conductors	Recommended values
▪ Cable type	▪ Shielded (not supplied)
▪ Cross section of wires	▪ 0,2...1,5 mm ²
▪ Length	▪ max. 50 m
▪ Operating temperature	▪ min. 80°C (min. 90°C for UL recognized version)

8.2.3 Dosing controller 8025 Batch in wall-mounting version

The electrical connection is done via terminal blocks and via five M16x1,5 cable glands.

Specifications of cables and conductors	Recommended values
▪ Cable type	▪ Shielded (not supplied)
▪ Cross section of wires	▪ 0,2...1,5 mm ²
▪ Diameter of each cable if only one cable is used per cable gland	▪ 5...8 mm
▪ Length	▪ max. 50 m
▪ Operating temperature	▪ min. 80°C

8.3 Equipotentiality of the installation

To ensure the equipotentiality of the installation (power supply - device - fluid):

- Connect together the various earth spots in the installation to eliminate the potential differences that may occur between different earthes.
- Observe faultless earthing of the shield of the power supply cable, at both ends.
- Connect the negative power supply terminal to the earth to suppress the effects of common mode currents. If this connection cannot be made directly, a 100 nF/50 V capacitor can be fitted between the negative power supply terminal and the earth.
- Special attention has to be paid if the device is installed on plastic pipes because there is no direct earthing possible. Proper earthing is performed by earthing together the metallic instruments such as pumps or valves, that are as close as possible to the device. If no such instrument is near the device, insert metallic earth rings inside the plastic pipes upstream and downstream the device and connect these parts to the same earth. The earth rings must be in contact with the fluid.

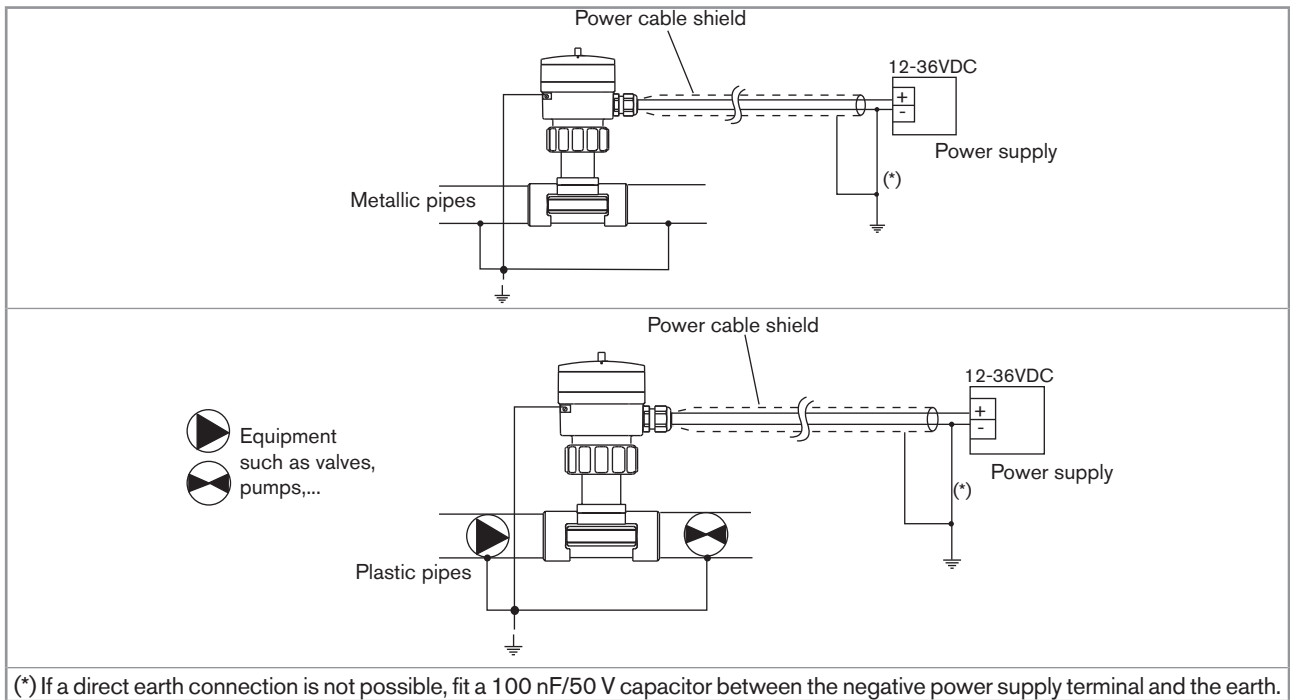

Fig. 20 : 8025 Batch in compact version, 8035 Batch and SE35 Batch, equipotentiality skeleton diagrams

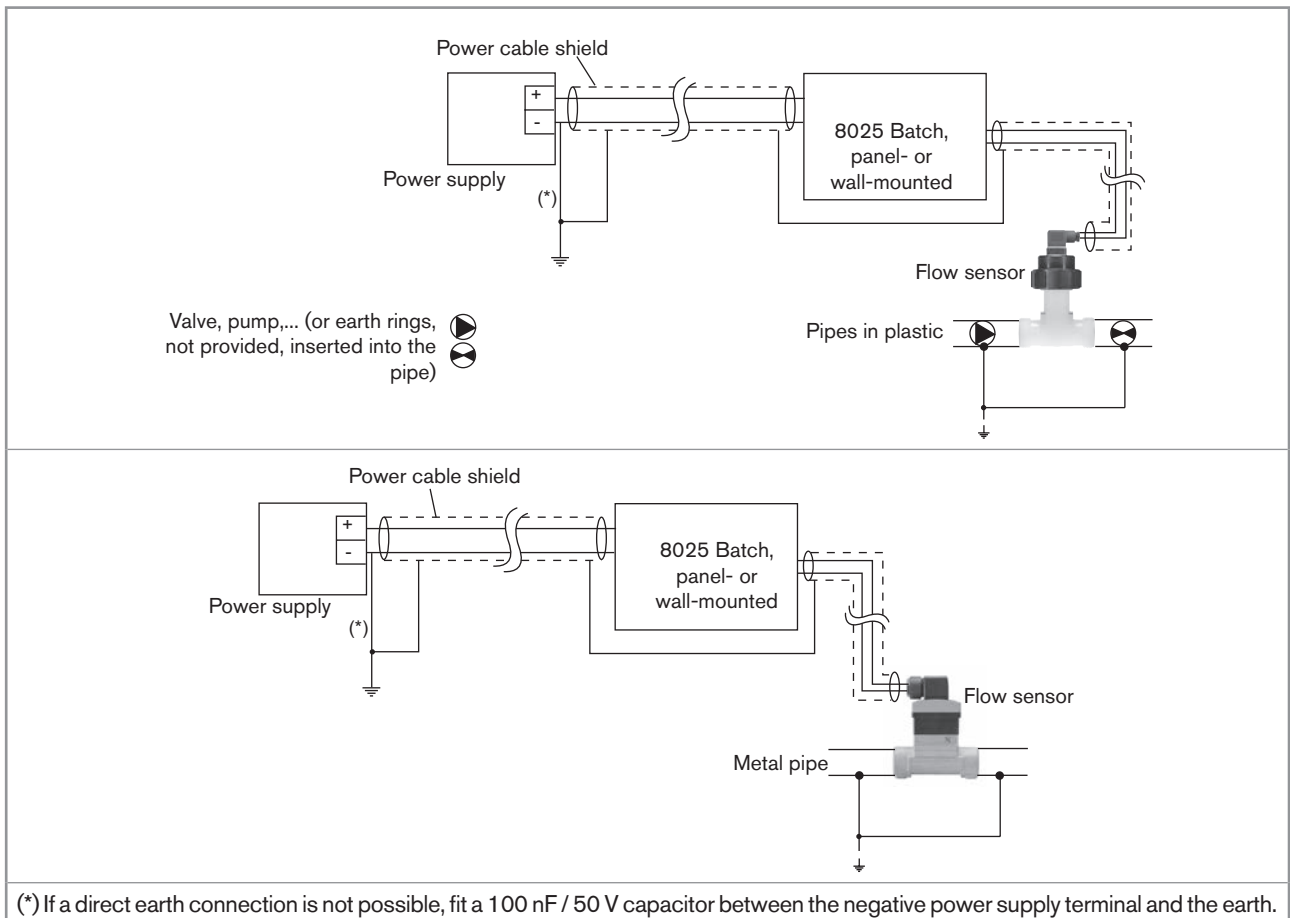

Fig. 21 : 8025 Batch in panel-mounted or in wall-mounted version, equipotentiality skeleton diagram

8.4 Default position of the selectors

! Only move the selectors when the power supply is off.

Tab. 1 : Default positions of selectors "SENSOR SUPPLY", "LOAD" and "SENSOR TYPE"

Selector	Default position
SENSOR SUPPLY (A)	L+
LOAD (B)	2.2KOhms
SENSOR TYPE (C)	NPN/PNP

8.5 Terminal assignment and use of the selectors

Terminal block 1

- NC: not connected
- L+: V+ (positive voltage)
- L-: 0V (power supply ground)
- PE: protective earth, factory wired
- P-: negative transistor output (DO1)
- P+: positive transistor output (DO1)

Terminal block 2

PE: shieldings of the power supply cable and the input / output cables

Terminal block 3: wiring the DO2 relay output.

Terminal block 4: wiring the DO3 relay output.

Connector 5: connection of the flow sensor

Terminal block 6 "BINARY"

- DI1 to DI4: 4 digital inputs
- DO4: transistor output
- ISOG: ISOGND, ground common to the 4 digital inputs and the transistor output DO4.
- PE: cable shielding

Selector (A): see chap. 8.6.

Selector (B): see chap. 8.6.

Selector (C): see chap. 8.6.

Fig. 22 : Terminal assignment of a 12...36 V DC fed version for the 8025 Batch in compact version, for the 8035 Batch and for the SE35 Batch

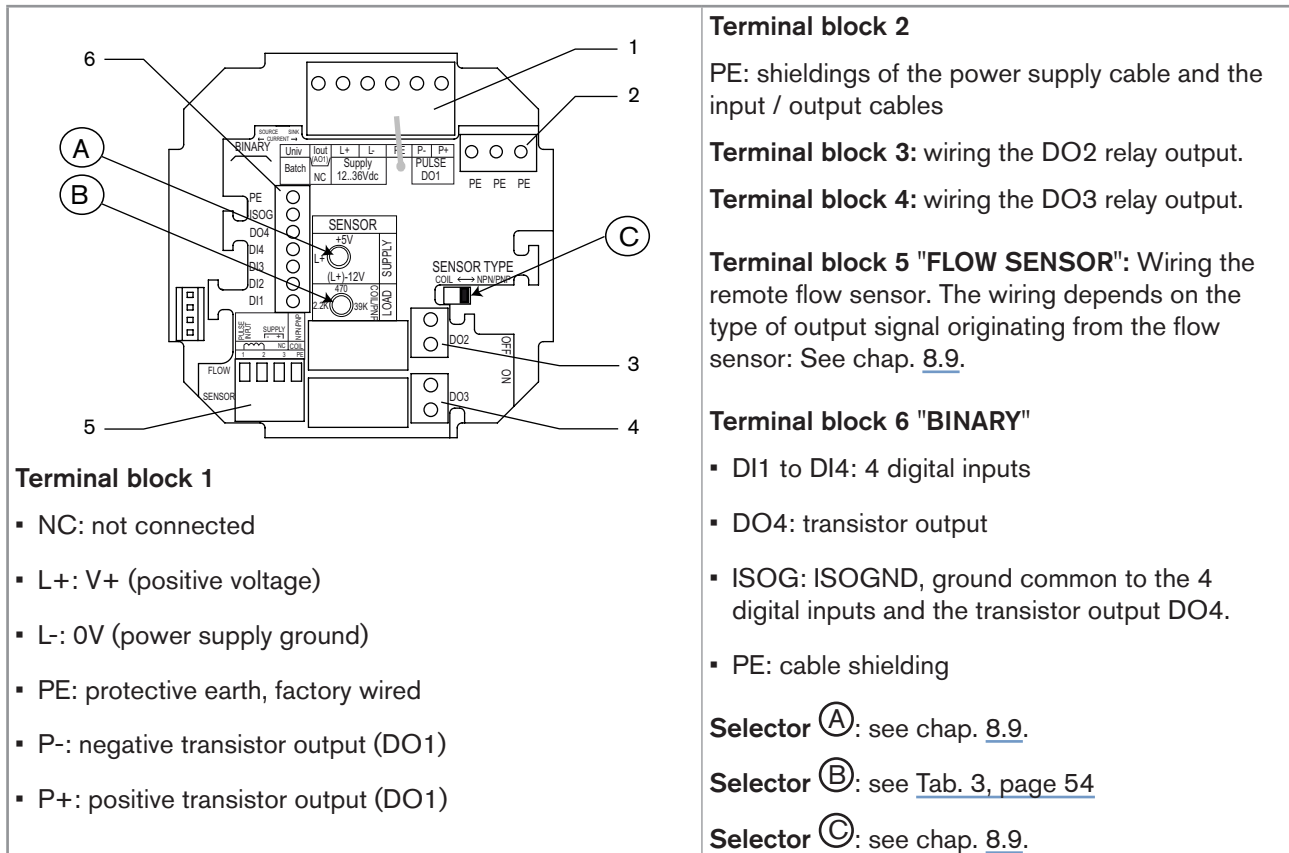
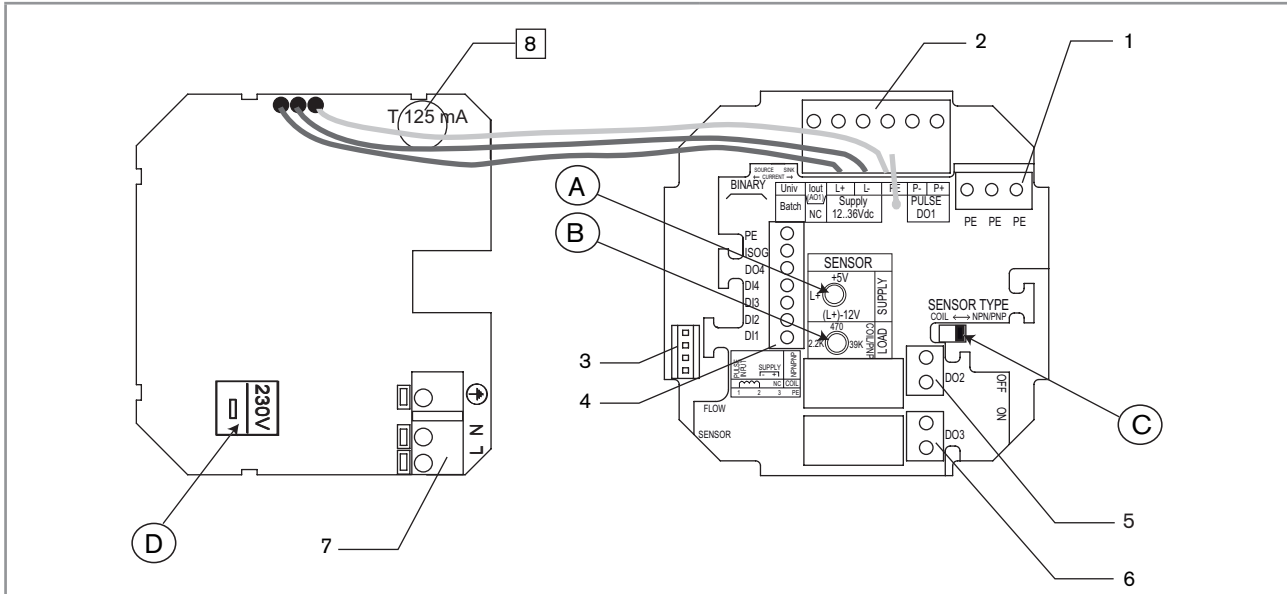

Fig. 23 : Terminal assignment of a 12...36 V DC fed version for the 8025 Batch in panel-mounted or in wall-mounted version



Terminal block 1

PE: shieldings of the power supply cable and the input / output cables

Terminal block 2

- NC: not connected
- L+: V+ (red wire, factory wired)
- L-: 0V (black wire, factory wired)
- PE: protective earth (green/yellow wire, factory wired)
- P-: negative transistor output (DO1)
- P+: positive transistor output (DO1)

Connector 3: connection of the flow sensor

Terminal block 4 "BINARY"

- DI1 to DI4: 4 digital inputs
- DO4: transistor output
- ISOG: ISOGND, ground common to the 4 digital inputs and the transistor output DO4.
- PE: cable shielding

Terminal block 5: wiring the DO2 relay output.

Terminal block 6: wiring the DO3 relay output.

Terminal block 7: wiring of the 115/230 V AC power supply

Mark 8: time-delay fuse to protect the 115/230 V AC power supply

Selector A: see chap. 8.6;

Selector B: see chap. 8.6;

Selector C: see chap. 8.6.

Selector D: see chap. 8.6.

Fig. 24 : Terminal assignment of a 115/230 V AC fed version for the 8025 Batch in compact version, for the 8035 Batch and for the SE35 Batch

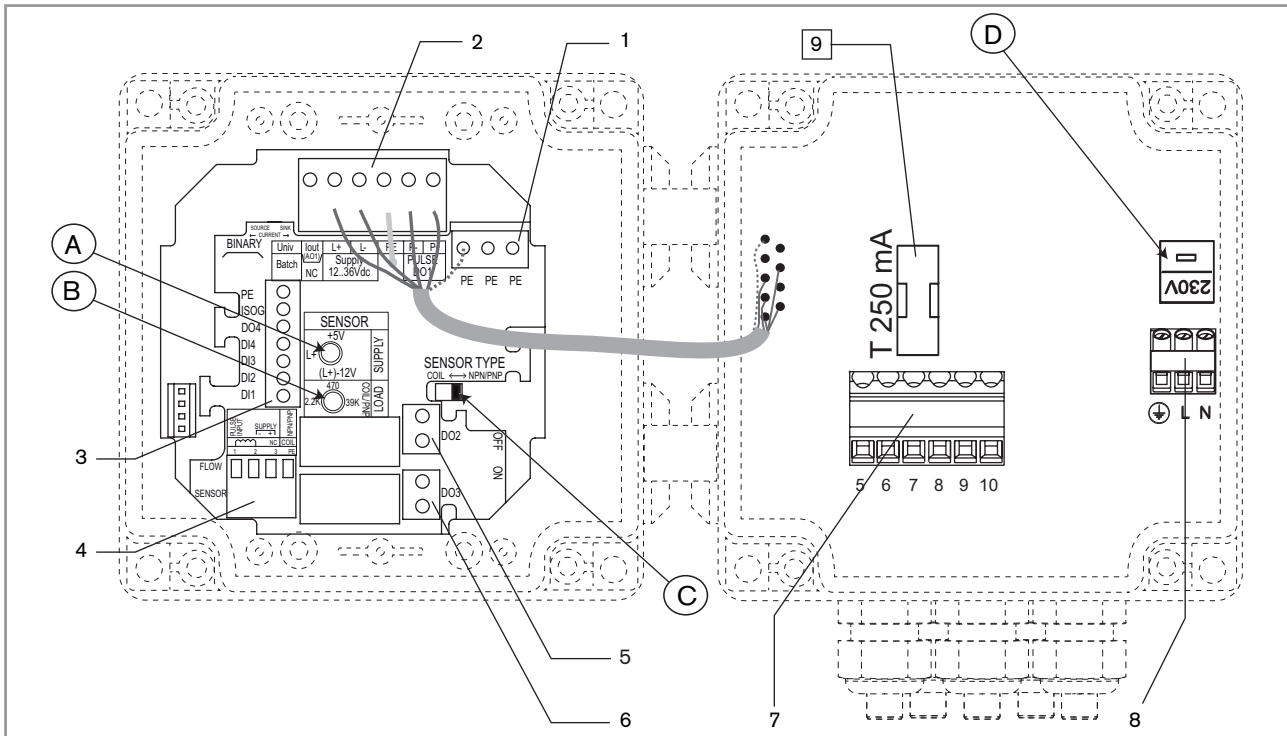

Terminal block 1

PE: factory wired shield.

Terminal block 2

- NC: not connected
- L+: V+ (red wire, factory wired)
- L-: 0V (black wire, factory wired)
- PE: protective earth, factory wired
- P-: negative transistor output (DO1) (brown wire, factory wired)
- P+: positive transistor output (DO1) (white wire, factory wired)

Terminal block 3 "BINARY"

- DI1 to DI4: 4 digital inputs
- DO4: transistor output
- ISOG: ISOGND, ground common to the 4 digital inputs and the transistor output DO4.
- PE: cable shielding

Terminal block 4 "FLOW SENSOR": Wiring the remote flow sensor. The wiring depends on the type of output signal originating from the flow sensor: see chap. 8.9.

Terminal block 5: wiring the DO2 relay output.

Terminal block 6: wiring the DO3 relay output.

Terminal block 7

- terminal 5 not connected
- terminal 6: positive 27 V DC power supply, available to energize an external instrument
- terminal 7: 0V (earth of the power supply available to energize an external instrument)
- terminal 8: protective earth for the cable shieldings
- terminal 9: negative transistor output (DO1)
- terminal 10: positive transistor output (DO1)

Terminal block 8: wiring of the 115/230 V AC power supply

Mark 9: time-delay fuse to protect the 115/230 V AC power supply

Selector A: see chap. 8.9.

Selector B: see Tab. 3, page 54.

Selector C: see chap. 8.9.

Selector D: see chap. 8.9.

Fig. 25 : Terminal assignment of a 8025 Batch in wall-mounted version, fed with 115/230 V AC

8.6 Wiring the 8025 Batch in compact version, the 8035 Batch or the SE35 Batch

 Only move the selectors when the power supply is off.

 Insert the supplied stopper gasket into the unused cable gland to ensure the tightness of the device.

- Unscrew the unused cable gland.
- Remove the transparent disk.
- Insert the supplied stopper gasket.
- Screw the nut of the cable gland.

→ Set the selector "SENSOR TYPE" on "NPN/PNP" (default position).

 Never set selector "SENSOR TYPE" on "COIL" on a compact version.

Selector  makes it possible to configure the type of signal received from the flow sensor.

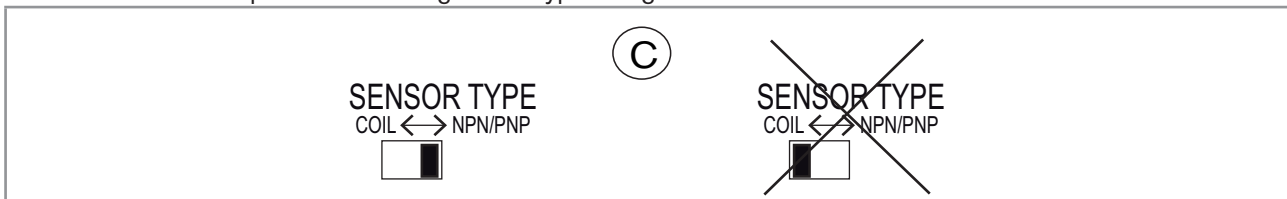

Fig. 26 : Using selector "SENSOR TYPE" on the 8025 Batch in compact version, the 8035 Batch or the SE35 Batch

→ Set selector "SENSOR SUPPLY" depending on the value of the power supply of the device. See [Tab. 2](#).

→ Set selector "LOAD": See [Tab. 2](#).

Tab. 2 : Position of selectors "SENSOR TYPE", "SENSOR SUPPLY" and "LOAD" on the 8025 Batch in compact version, the 8035 Batch or the SE35 Batch

Selector "SENSOR TYPE" Ⓒ	Selector "SENSOR SUPPLY" Ⓐ	Selector "LOAD" Ⓑ
<p>→ Set the selector on "NPN/PNP" (Fig. 26)</p>	<p>The flow sensor of the device needs a minimum voltage supply of 5 V DC :</p> <ul style="list-style-type: none"> → If the device is fed with a voltage ≥ 12 V DC and < 17 V DC, set the voltage selector "SENSOR SUPPLY" on "5V" or "L+". → If the device is fed with a voltage ≥ 17 V DC, the voltage selector "SENSOR SUPPLY" can be set to any position. → If the device is fed with a 115/230V AC voltage, set the voltage selector "SENSOR SUPPLY" on "L+". 	<p>→ Set selector "LOAD":</p> <ul style="list-style-type: none"> ▪ either on "2.2k": the load resistance R is then 2,2 kΩ ▪ either on "470": the load resistance R is then 470 Ω

→ If the device is energized with a 115/230 V AC power supply, set selector Ⓓ as shown in Fig. 27.

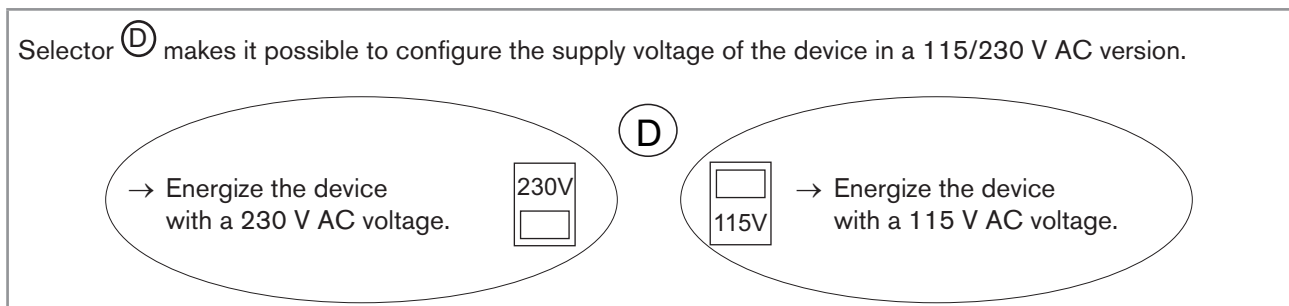

Fig. 27 : Selector of the supply voltage on a 115/230 V AC version

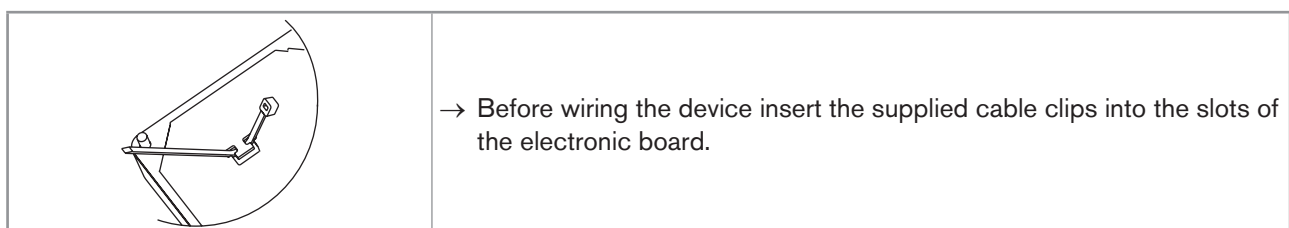

Fig. 28 : Inserting the cable clips

- Install the device as described in chap. [7.2](#), [7.3](#) or [7.4](#).
- Wire acc. to chap. [8.11](#), [8.14](#) and [10.6](#).
- Secure the power supply cable and the relay connection cables, with the cable clips.
- Close the housing and tighten the 4 screws of the cover.

8.7 Wiring the 8025 Batch in panel version

! Only move the selectors when the power supply is off.

→ Install the device as described in chap. [7.5](#).

→ Set the selectors "SENSOR TYPE", "SENSOR SUPPLY" and "LOAD": see chap. [8.9 Connecting the remote flow sensor to a 8025 Batch in panel-mounted or in wall-mounted version](#).

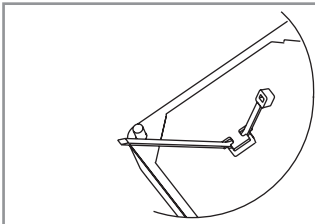

→ Before wiring the device insert the supplied cable clips into the slots of the electronic board.

Fig. 29 : Inserting the cable clips

→ Wire according to chap. [8.9](#), [8.11](#), [8.14](#) and [10.6](#).

→ Secure the power supply cable, the flow sensor connection cable and the relay connection cables, with the cable clips.

8.8 Wiring the 8025 Batch in wall-mounted version

! Only move the selectors when the power supply is off.

! Insert the supplied stopper gaskets into the unused cable glands to ensure the tightness of the device.

- Unscrew the unused cable gland.
- Remove the transparent disk.
- Insert the supplied stopper gasket.
- Screw the nut of the cable gland.

→ Install the device as described in chap. [7.6](#).

→ Set the selectors "SENSOR TYPE", "SENSOR SUPPLY" and "LOAD": see chap. [8.9 Connecting the remote flow sensor to a 8025 Batch in panel-mounted or in wall-mounted version](#).

→ If the wall-mounted version is energized with a 115/230 V AC power supply, set selector **Ⓓ** as shown in [Fig. 30](#).

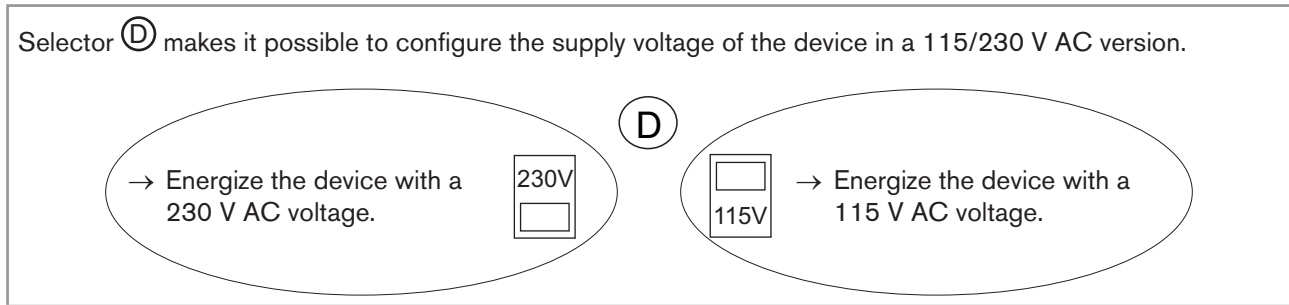

Fig. 30 : Selector of the supply voltage on a 115/230 V AC version

- Loosen the nuts of the cable glands.
- Insert each cable through a nut than through the cable gland, using the cable glands as shown in [Fig. 31](#).

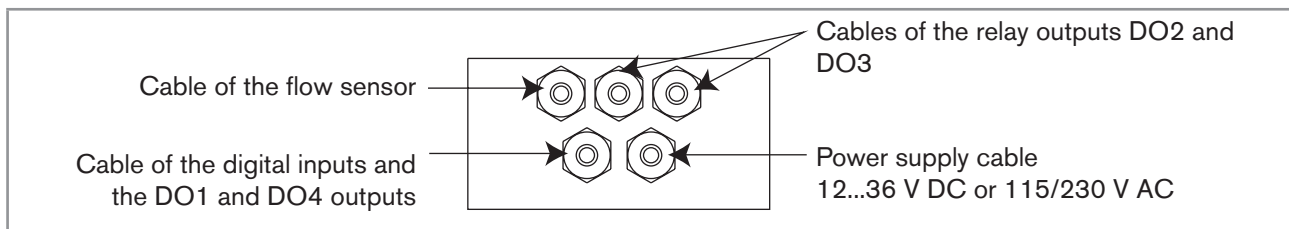

Fig. 31 : Using the cable glands on a wall-mounted version

- On a 115/230 V AC fed wall-mounted version, remove both terminal blocks (marked 7 and 8 in [Fig. 25](#)) from the housing.

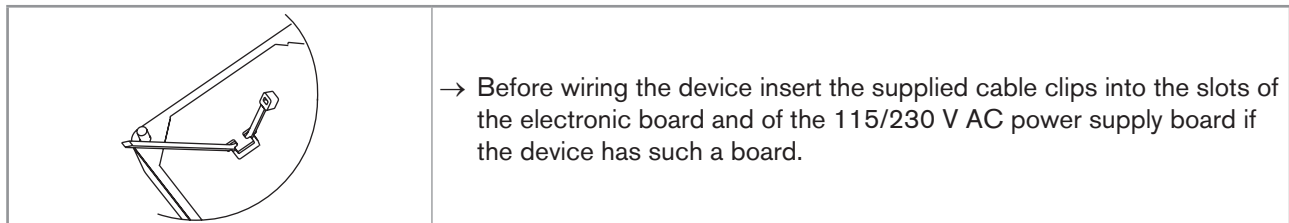

Fig. 32 : Inserting the cable clips

- Depending on the operating voltage of the device, wire according to chap. [8.9](#), [8.11](#) to [8.14](#) and [10.6](#).
- Insert the two terminal blocks (marked 7 and 8 in [Fig. 25](#), page 48) into their original position.
- Letting the housing stay completely open, secure the power supply cable, the flow sensor connection cable and the relay connection cables, with the cable clips.
- Tighten the cable glands making sure the cable in the housing is long enough to allow complete opening of the housing.
- Close the cover.
- Tighten the 4 screws.
- Put the blanking strips on the housing.

8.9 Connecting the remote flow sensor to a 8025 Batch in panel-mounted or in wall-mounted version

! Only move the selectors when the power supply is off.

! Before connecting the flow sensor to the dosing controller 8025 Batch, in panel-mounted or in wall-mounted version:

- Set selector "SENSOR TYPE" depending on the output signal originating from the flow sensor. See Fig. 33 and Tab. 3, page 54.
- If selector "SENSOR TYPE" is set on "NPN/PNP", set selector "SENSOR SUPPLY" depending on the dosing controller supply voltage. See Fig. 34 and Tab. 3, page 54.
- Set selector "LOAD" depending on the type of signal sent out by the flow sensor and on the load wanted on terminal 1 "PULSE INPUT" of terminal block "FLOW SENSOR". See Tab. 3, page 54.

Selector **C** makes it possible to configure the type of signal the device, receives from the remote flow sensor.

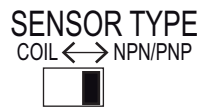

Set the selector on "NPN/PNP" (default position) when the signal from the flow sensor which is connected to the device is either:

- a pulse signal, NPN or PNP
- an "on/off" signal (Reed relay for example)
- a 0-5 V DC standard voltage signal (TTL, for example)

C

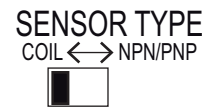

→ Set the selector on "COIL" when the signal from the flow sensor which is connected to the device is a sine-wave signal (coil).

Fig. 33 : Using selector "SENSOR TYPE" on the 8025 Batch in panel or in wall-mounted version

When selector "SENSOR TYPE" above is set on "NPN/PNP", selector **A** makes it possible to configure the supply voltage for the remote flow sensor.

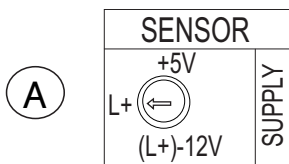



→ If the device is energized with a 115/230 V AC power supply, set selector "SENSOR SUPPLY" on "L+" (default position).

→ If the device is energized with a 12...36 V DC power supply, set the voltage selector "SENSOR SUPPLY" depending on the voltage supply needed by the remote flow sensor: "+5V", "L+" or "(L+)-12V" (default position).

Fig. 34 : Using selector "SENSOR SUPPLY" on the 8025 Batch in panel or in wall-mounted version

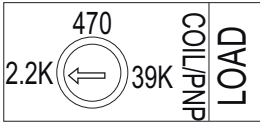
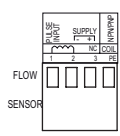
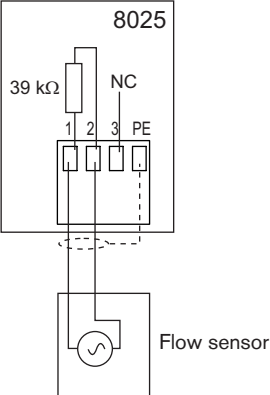
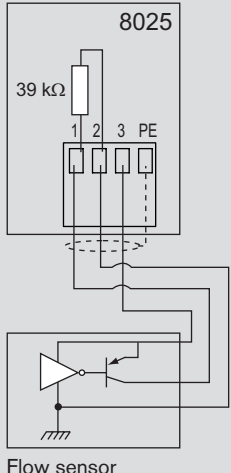
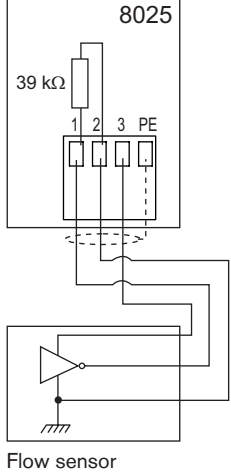
Tab. 3 : Position of selectors "SENSOR TYPE" and "LOAD" of the 8025 Batch in panel or in wall-mounted version, and terminal assignment of terminal block "FLOW SENSOR" depending on the signal emitted by the remote flow sensor

Type of signal emitted by the remote flow sensor	Selector "SENSOR TYPE" Ⓒ	Selector "SENSOR SUPPLY" Ⓐ	Selector "LOAD" Ⓑ	Terminal assignment of terminal block "FLOW SENSOR"
sine-wave (coil)	→ Set the selector on "COIL" (Fig. 33)	→ Any position.		
			→ Set selector "LOAD" on "39K": the input impedance on terminals 1 and 2 of terminal block "FLOW SENSOR" will then be 39 kΩ	
pulse, PNP	→ Set the selector on "NPN/PNP" (Fig. 33)	→ Set the selector as shown in Fig. 34.	→ Set selector "LOAD" on "39K": the input impedance on terminals 1 and 2 of terminal block "FLOW SENSOR" will then be 39 kΩ	
0-5 V DC standard voltage signal (TTL, for example)	→ Set the selector on "NPN/PNP" (Fig. 33)	→ Set the selector as shown in Fig. 34.	→ Set selector "LOAD" on "39K": the input impedance on terminals 1 and 2 of terminal block "FLOW SENSOR" will then be 39 kΩ	

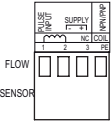
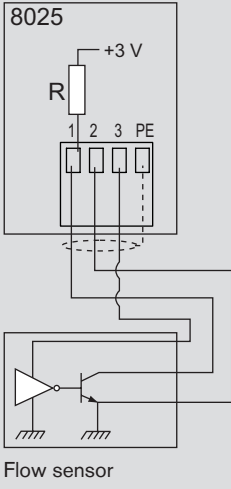
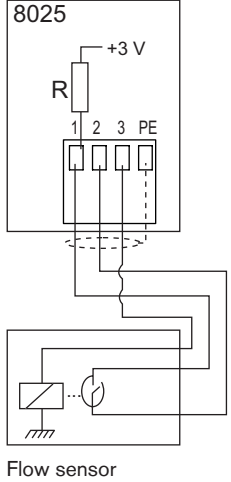
Type of signal emitted by the remote flow sensor	Selector "SENSOR TYPE" (C)	Selector "SENSOR SUPPLY" (A)	Selector "LOAD" (B) 	Terminal assignment of terminal block "FLOW SENSOR" 
pulse, NPN	→ Set the selector on "NPN/PNP" (Fig. 33)	→ Set the selector as shown in Fig. 34.	→ Set selector "LOAD": <ul style="list-style-type: none"> ▪ either on "2.2k": the load resistance R is then 2,2 kΩ ▪ either on "470": the load resistance R is then 470 Ω 	 <p>Flow sensor</p>
"on/off" signal (Reed relay for example)	→ Set the selector on "NPN/PNP" (Fig. 33)	→ Set the selector as shown in Fig. 34.	→ Set selector "LOAD": <ul style="list-style-type: none"> ▪ either on "2.2k": the load resistance R is then 2,2 kΩ ▪ either on "470": the load resistance R is then 470 Ω 	 <p>Flow sensor</p>

8.10 Wiring the digital inputs DI1 to DI4 and the transistor output DO4

Wiring of the digital inputs DI1 to DI4 and wiring of the transistor output DO4 are described in chap. [10.6.1](#) to [10.6.7](#), because they depend on the dosing mode configured.

MAN 1000199281 EN Version: C Status: RL (released | freigegeben) printed: 22.09.2017

8.11 Wiring the DO1 transistor output of device, fed with 12...36 V DC

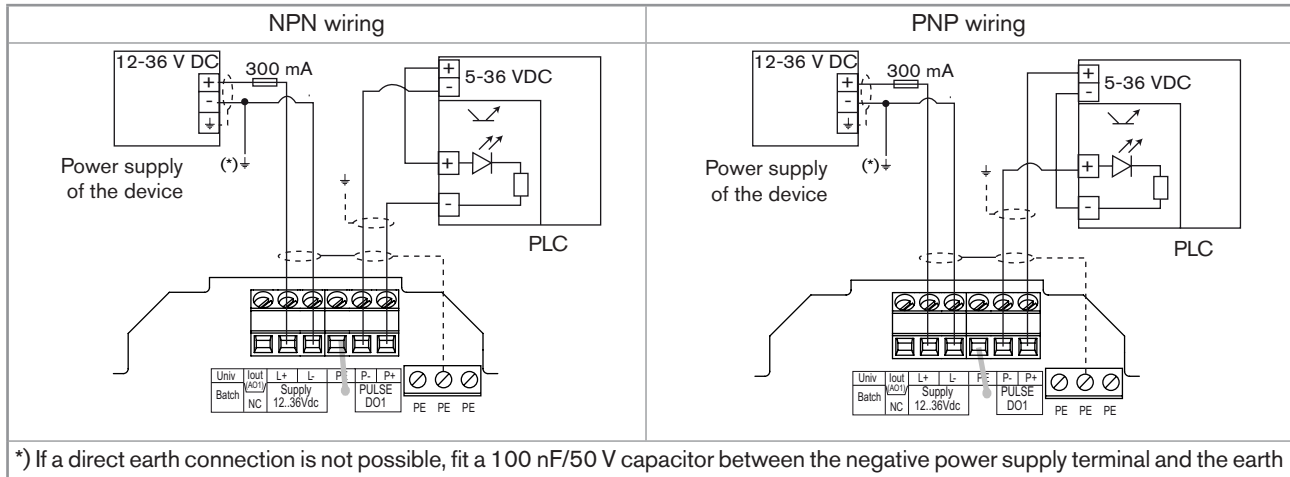

Fig. 35 : NPN or PNP wiring of the DO1 transistor output of the device

→ Configure transistor output DO1 acc. to chap. [10.7.19](#) to [10.7.23](#).

8.12 Wiring the DO1 transistor output of a version fed with 115/230 V AC for the 8025 Batch in compact version, for the 8035 Batch or for the SE35 Batch

→ Wire the transistor output DO1 as described in chap. [8.11](#).

→ Configure transistor output DO1 acc. to chap. [10.7.19](#) to [10.7.23](#).

8.13 Wiring the DO1 transistor output of the 8025 Batch in wall-mounted version, fed with 115/230 V AC

! Only move the selectors when the power supply is off.

! Position selector **D** depending on the value of the power supply.

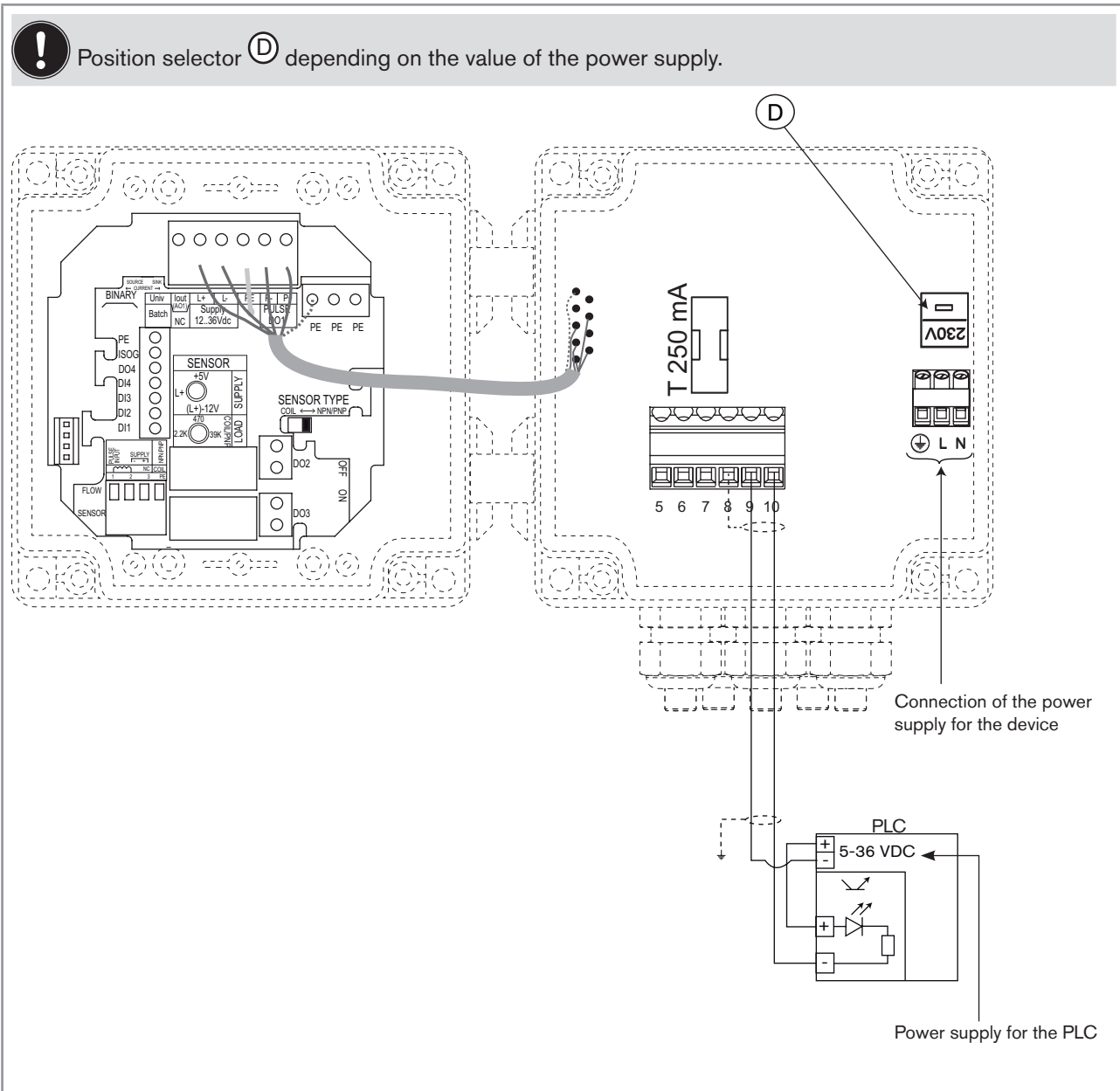

Fig. 36 : NPN wiring of the DO1 transistor output of a 8025 Batch in wall-mounted version, fed with 115/230 V AC

→ Configure transistor output DO1 according to chap. [10.7.19](#) to [10.7.23](#).

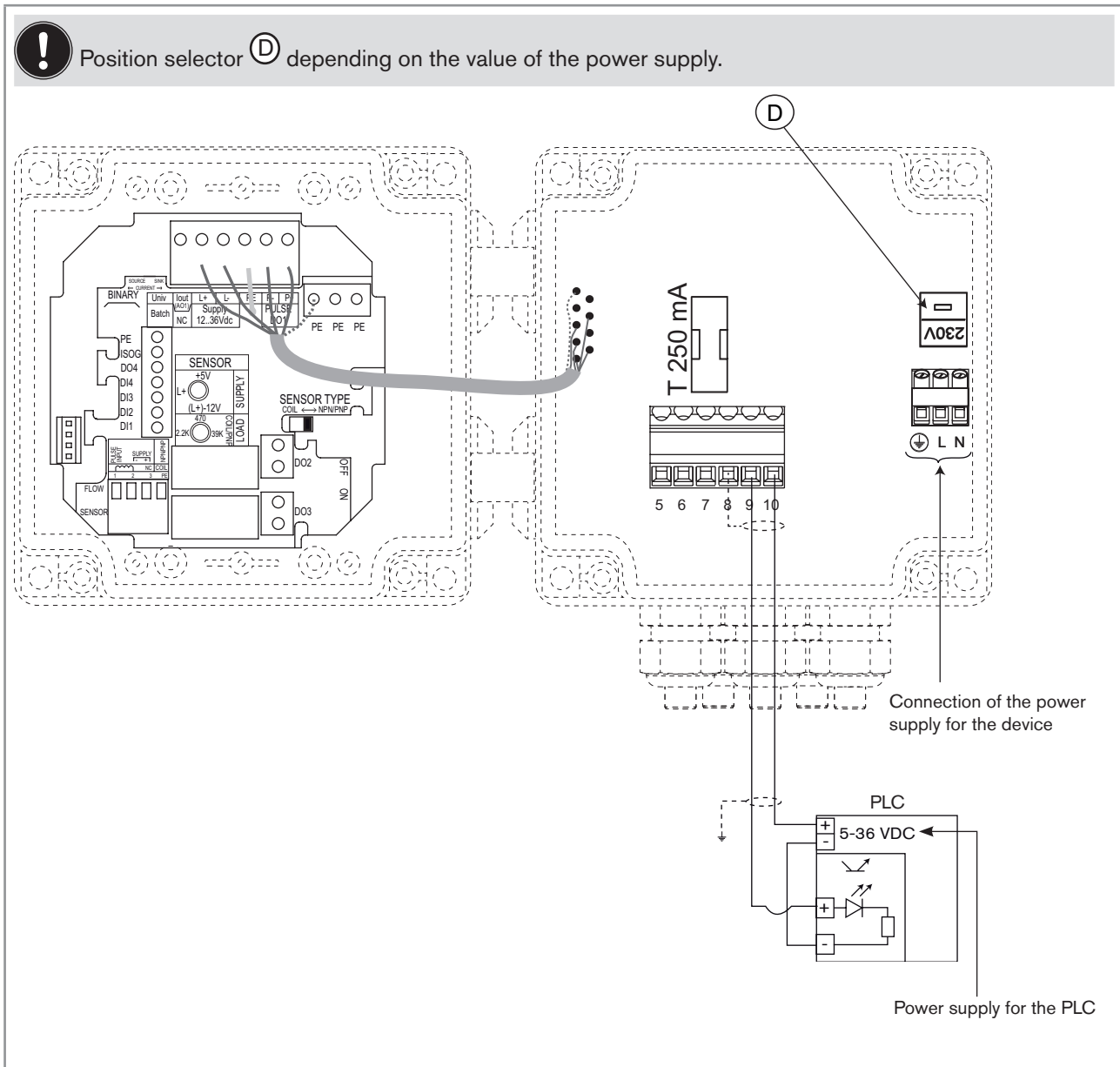

Fig. 37 : PNP wiring of the DO1 transistor output of a 8025 Batch in wall-mounted version, fed with 115/230 V AC

→ Configure transistor output DO1 according to chap. [10.7.19](#) to [10.7.23](#).

8.14 Wiring the relay outputs DO2 and DO3 of a device



To do a dosing, connect a valve to the relay output DO2.

The device can control:

- either a dosing with a single valve connected to the relay output DO2.
- or a dosing with 2 valves connected to the relay outputs DO2 and DO3. In this case, connect the main valve (for the highest flow rates) to output DO2 and the auxiliary valve (for low flow rates) to output DO3.

If a single valve is used, connect a load to relay output DO3 suited for the configuration of the output.

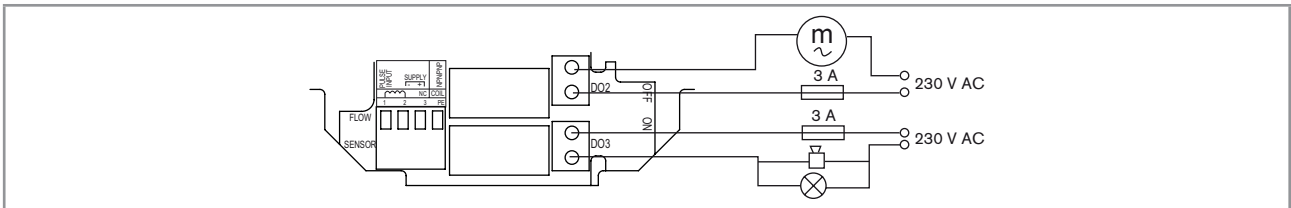

Fig. 38 : Wiring of the DO2 and DO3 relay outputs

→ To configure relay output DO2, see chap. [10.7.24](#).

→ To configure relay output DO3, see chap. [10.7.18](#).

9 COMMISSIONING

9.1 Safety instructions



WARNING

Danger due to non-conforming commissioning.

Non-conforming commissioning could lead to injuries and damage the device and its surroundings.

- ▶ Before commissioning, make sure that the staff in charge have read and fully understood the contents of the operating instructions.
- ▶ In particular, observe the safety recommendations and intended use.
- ▶ The device / the installation must only be commissioned by suitably trained staff.



Protect this device against electromagnetic interference, ultraviolet rays and, when installed outdoors, the effects of the climatic conditions.

9.2 Commissioning procedure

Before commissioning the device:

- Enter the K-factor of the fitting used. See chap. [10.7.3](#).
- Wire the device depending on the desired dosing mode. See chap. [8](#) and chap. [10.6.1](#) to [10.6.7](#).
- If the digital inputs are used, place DI4 in the off-position before energizing the device.
- Set the dosing mode. See chap. [10.7.5](#).

10 OPERATING AND FUNCTIONS

10.1 Safety instructions



DANGER

Danger due to electrical voltage.

- ▶ Disconnect the electrical power for all the conductors and isolate it before carrying out work on the system.
- ▶ Observe all applicable accident protection and safety regulations for electrical equipment.



WARNING

Risk of injury due to non-conforming operating.

Non-conforming operating could lead to injuries and damage the device and its surroundings.

- ▶ The operators in charge of operating must have read and understood the contents of these operating instructions.
- ▶ In particular, observe the safety recommendations and intended use.
- ▶ The device/installation must only be operated by suitably trained staff.

10.2 Operating levels of the device

The device has two operating levels: the Process level and the Configuration level.

The Process level allows for:

- starting a dosing.
- reading the values of the main and daily totalizers of the quantity of fluid counted since the last reset.
- reading the values of the main and daily totalizers of the done dosings since the last reset.
- resetting the daily volume or mass totalizer:
- resetting the daily totalizer of the done dosings.
- accessing the Configuration level.

The Configuration level comprises four menus (Parameters, Test, Information and History) and allow for:

- setting the device parameters.
- setting the dosing mode on the device.
- doing the Teach-In of the quantity to be dosed (only if dosing modes "LOC. REP" or "EXT. REP" are active on the device).
- testing the inputs and the outputs of the device.
- reading and confirming, when the device state LED is orange or red and when no dosing is being done, the warning and fault messages generated by the device.
- consulting the history of the last 10 dosings.

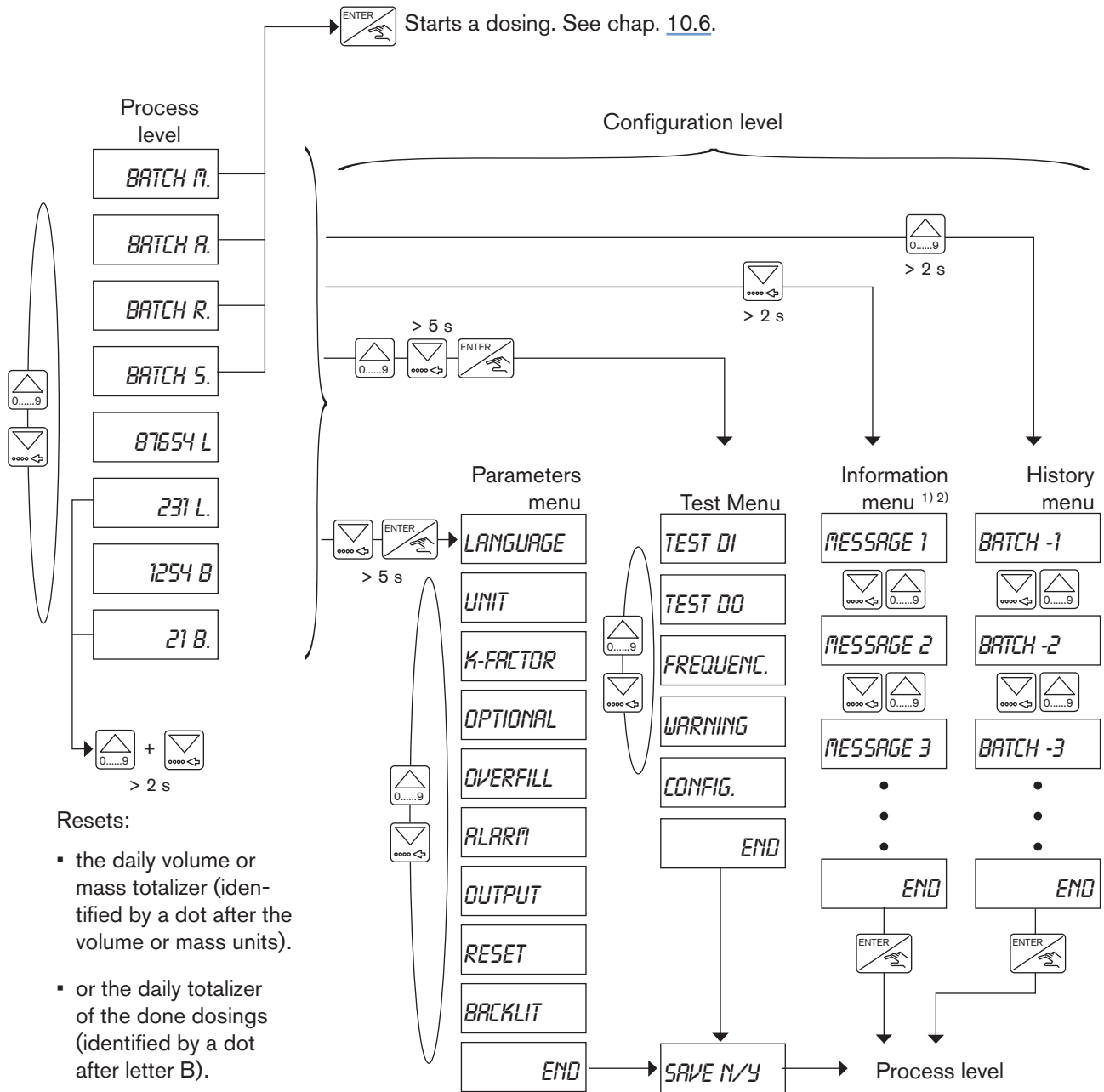



¹⁾ Accessible when the device state LED is orange or red and when no dosing is being done (see chap. 10.3).

²⁾ The warning messages of the menu can also be remotely consulted and confirmed: see chap. 10.11.

10.3 Description of the navigation keys and the state LEDs



















The diagram shows a blue Bürkert device with a digital display and several control buttons. Callouts point to various components:

- Navigation Keys:**
 - Up arrow key: Scrolling up the parameters
 - Down arrow key: Incrementing the figure selected
 - ENTER key: Confirming the settings
 - Left arrow key: Selecting the displayed parameter
 - 0.....9 key: Consulting the history of dosings
- State LEDs:**
 - Device state LED: see following table.
 - State LED of relay output DO3 (LED ON = contact closed)
 - State LED of relay output DO2 (LED ON = contact closed)

Device state LED	State of the device
Green	The device operates correctly.
Orange	<p>An alarm related to the dosing and/or a warning message has been generated.</p> <p>→ Press the  key for 2 seconds in the Process level to access the message if no dosing is being done. See chap. 11.3 for the meaning of the message.</p> <p>Furthermore, output DO1, DO3 or DO4 switches if configured with the function "ALARM" (see chap. 10.7.19) or with the function "WARNING" (see chap. 10.7.20)</p>
Red	<p>An error message has been generated.</p> <p>The transistor output DO4 sends out a 10 Hz frequency, if parameter "ERR. 10HZ" is set to "10HZ ON". See chap. 10.7.26.</p> <p>→ Press the  key for 2 seconds in the Process level to access the message if no dosing is being done. See chap. 11.3 for the meaning of the message.</p>
flashing, whatever the colour	<ul style="list-style-type: none"> ▪ Slow flashing: the dosing has been interrupted. ▪ Fast flashing, during a dosing: an alarm related to the dosing has been generated. ▪ Fast flashing when no dosing is being done: the Information menu is being remotely consulted (via the digital inputs, see chap. 10.11) or the function of the digital inputs or of the outputs is being checked (see chap. 10.8.1 or 10.8.2).

MAN 1000199281 EN Version: C Status: RL (released | freigegeben) printed: 22.09.2017

10.4 Using the navigation keys

You want to...	Press...
move between parameters within a level or a menu.	<ul style="list-style-type: none">  to go to the next parameter.  to go to the previous parameter.
access the Parameters menu.	 +  simultaneously for 5 s, in the Process level, if no dosing has been started.
access the Test menu.	 +  +  simultaneously for 5 s, in the Process level, if no dosing has been started.
access the Information menu.	 for 2 s, in the Process level, when the device state LED is orange or red and no dosing has been started.
access the History menu.	 for 2 s, in the Process level, if no dosing has been started.
reset the daily volume or mass totalizer, from the Process level.	 +  simultaneously for 2 s, when the daily volume or mass totalizer is displayed in the Process level
reset the daily totalizer of the done dosings, from the Process level.	 +  simultaneously for 2 s, when the daily totalizer of the done dosings is displayed in the Process level
select the displayed parameter.	
confirm the displayed value.	
modify a numerical value.	<ul style="list-style-type: none">  to increase the blinking digit.  to select the digit at the left of the blinking digit.  +  to move the decimal point.

→ To start a dosing, see chap. [10.6](#).

10.5 Principle of a dosing and PLC scenarios

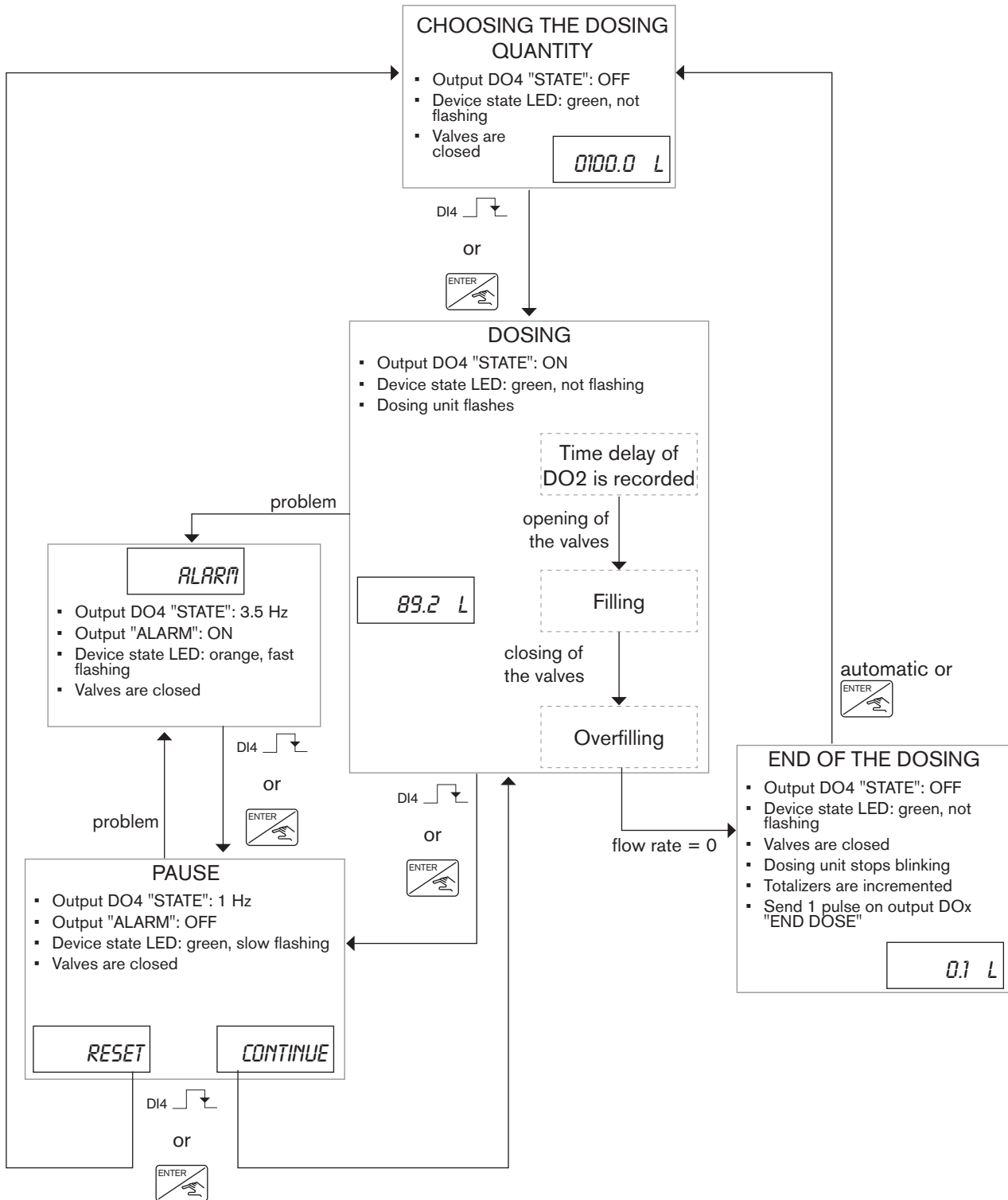

→ The different dosing modi are described in chap. [10.7.5](#).

Tab. 4 : Scenario of a dosing with no problem nor pause

Event	state, output DO4
no dosing	OFF
dosing	ON
end of the dosing	OFF

Tab. 5 : Scenario of a dosing with pause

Event	state, output DO4
no dosing	OFF
dosing	ON
dosing interrupted	1Hz
dosing continued	<ul style="list-style-type: none"> ▪ ON if the dosing is not finished ▪ OFF if the dosing finished during the pause
or reset the dosing	OFF

Tab. 6 : Scenario of a dosing with alarm

Event	state, output DO4
no dosing	OFF
dosing	ON
ALARM	3.5 Hz
confirm the alarm	<ul style="list-style-type: none"> ▪ OFF if the dosing finished during the alarm ▪ 1Hz if the dosing is not finished: the dosing has been interrupted. See Tab. 5.

Tab. 7 : Scenario of a dosing with pause and alarm during the pause

Event	state, output DO4
no dosing	OFF
dosing	ON
dosing interrupted	1Hz
ALARM	3.5 Hz
confirm the alarm	<ul style="list-style-type: none"> ▪ OFF if the dosing finished during the alarm ▪ 3.5 Hz if the dosing is not finished: the dosing has been interrupted. See Tab. 5.

Tab. 8 : Scenario of a dosing with ERROR[T]

Event	state, output DO4
no dosing	OFF
dosing	ON
ERROR[T]	3.5 Hz
confirm the alarm	<p>OFF</p> <p>(no pulse sent out on DOx output configured with function "END DOSE")</p>

MAN 1000199281 EN Version: C Status: RL (released | freigegeben) printed: 22.09.2017

10.6 Details of the Process level

This level is active by default when the device is energized.



If the power supply of the device is shut down while a dosing is being done, the dosing has been interrupted when the power supply is restored: to continue or abort the dosing depending on the dosing mode that is active on the device, see chap. [10.6.1](#) to [10.6.7](#).

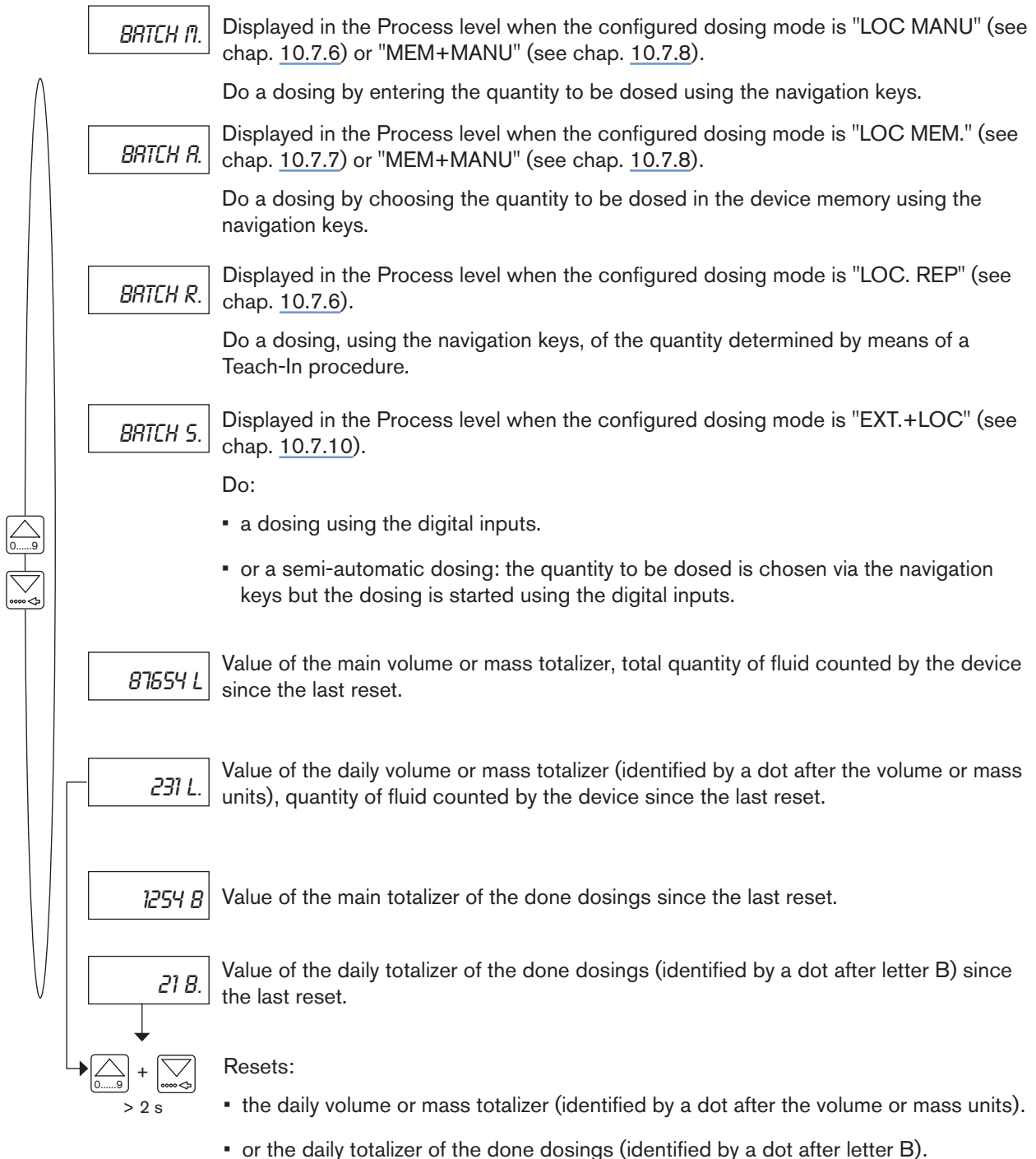

10.6.1 Doing a dosing in dosing mode "LOC. MANU." or "MEM.+MANU."

Dosing mode "LOC. MANU." allows for entering a dosing quantity and starting the dosing, via the navigation keys.

Dosing mode "MEM.+MANU." allows for:

- either entering a dosing quantity and starting the dosing, via the navigation keys,
- or starting the dosing, via the navigation keys, of a quantity saved in the memory.

DANGER

Danger due to electrical voltage.

- ▶ Disconnect the electrical power for all the conductors and isolate it before carrying out work on the system.
- ▶ Observe all applicable accident protection and safety regulations for electrical equipment.

→ Connect the valves to the DO2 and DO3 outputs: see chap. 8.14.

→ Wire the output DO4 as described in Fig. 39.

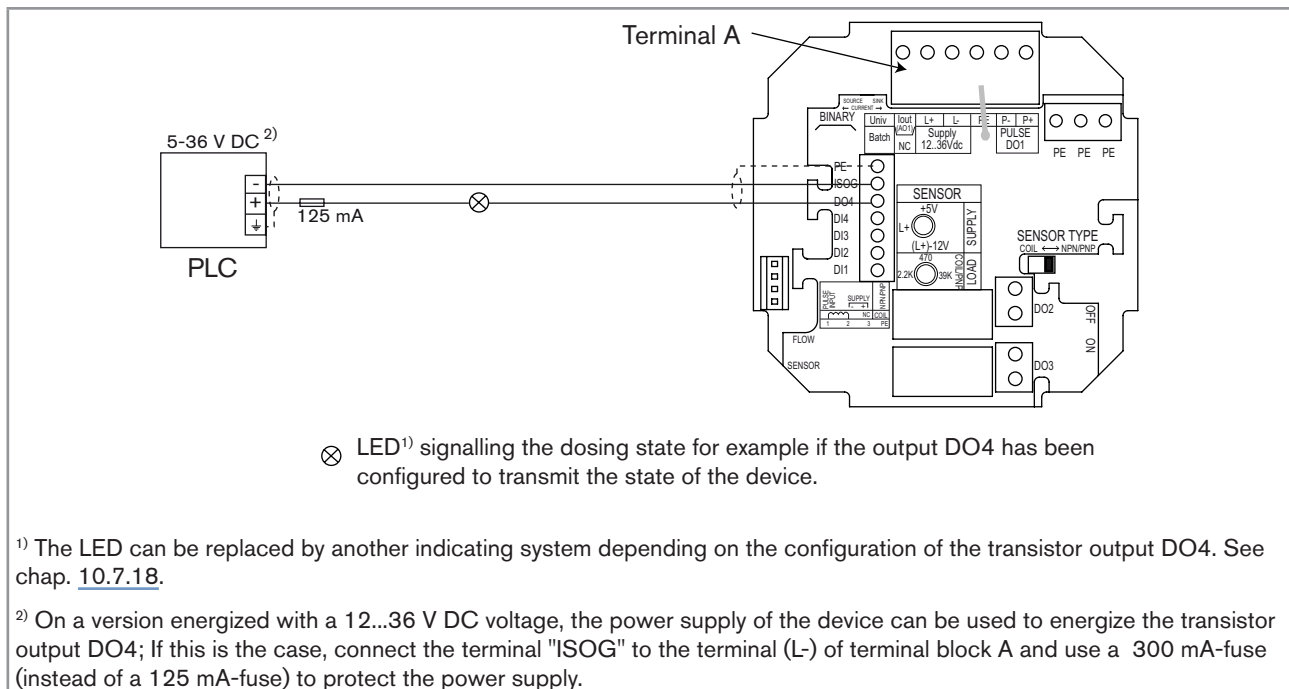

Fig. 39 : Electrical connection of the transistor output DO4 in the dosing modes "LOC. MANU.", "LOC. MEM.", "MEM+MANU" or "LOC. REP"

→ Start the device again.

→ Configure the device with the dosing mode "LOC. MANU." or "MEM.+MANU.": see chap. 10.7.6 or 10.7.8.

→ Do a dosing as shown in Fig. 40.



- If the generation of alarms (alarm "DURING") for problems occurring during a dosing has been activated (see chap. 10.7.16), an alarm is generated if there is no flow rate measured in the pipe whereas the valves are open. See chap. 11.3.4 to solve the problem.
- If the generation of alarms (alarm "AFTER") for problems occurring at the end of the dosing has been activated (see chap. 10.7.17), an alarm is generated if there is still flow in the pipe whereas the valves are closed. See chap. 11.3.4 to solve the problem.

Process level



→ Confirm.

→ Enter a dosing quantity (value between 0.0001 and 99999 dosing units, where the units have been selected in chap. 10.7.2) higher or equal to 6 divided by the fitting K-factor (in pulse/litre).

→ Confirm.

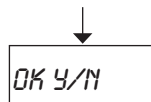

→ Choose "OK Y" to start the dosing.

→ Confirm.

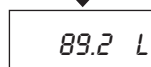

The dosing quantity is counted down until 0 (the dosing units blink).

→ To read the flow rate measured in the pipe, press or .

→ To read the total dosing quantity, press or once.

→ To interrupt the dosing, see Fig. 41.

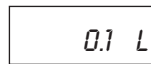

When the dosing is finished:

- the dosing units do not blink any more,
- and the valves are closed.

→ To go back to the Process level in order to start a new dosing, press .

Fig. 40 : Doing a manual dosing in dosing modes "LOC. MANU." or "MEM.+MANU."

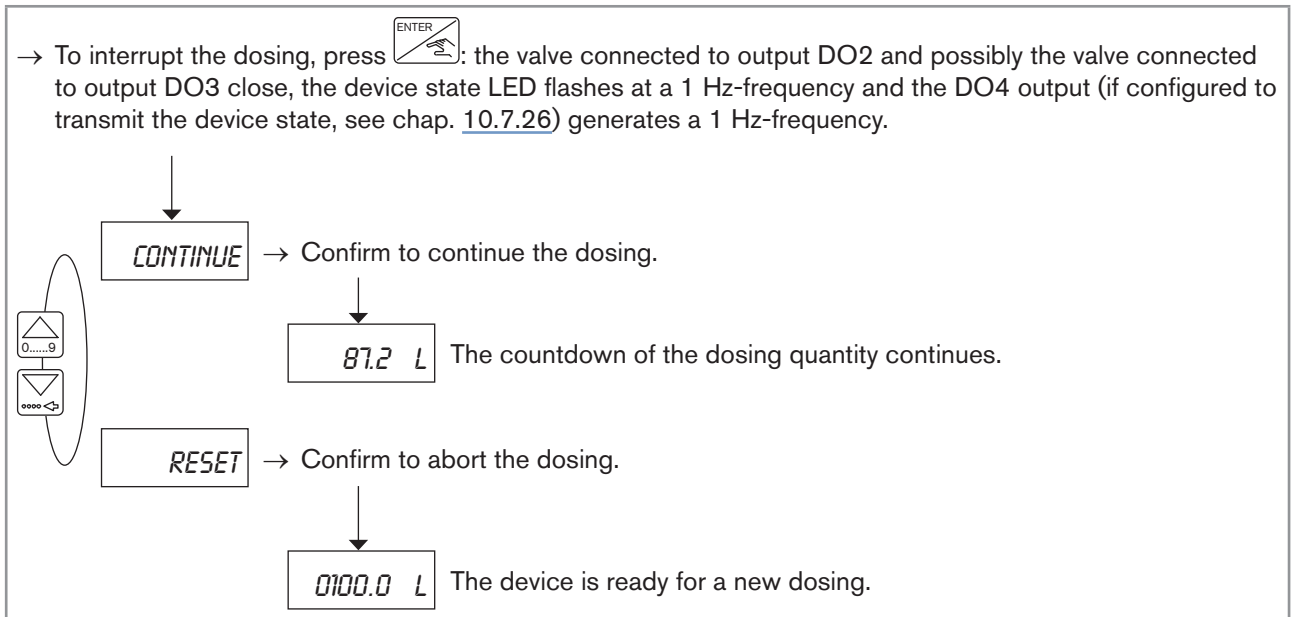

Fig. 41 : Interrupting the dosing in dosing modes "LOC. MANU." or "MEM.+MANU."

10.6.2 Doing a dosing in dosing mode "LOC. MEM." or "MEM.+MANU."

Dosing mode "LOC. MEM." allows for starting the dosing, via the navigation keys, of a quantity saved in the memory.

Dosing mode "MEM.+MANU." allows for:

- either entering a dosing quantity and starting the dosing, via the navigation keys,
- or selecting a dosing quantity from the memory and starting the dosing, via the navigation keys,

DANGER

Danger due to electrical voltage.

- ▶ Disconnect the electrical power for all the conductors and isolate it before carrying out work on the system.
- ▶ Observe all applicable accident protection and safety regulations for electrical equipment.

→ Connect the valves to the DO2 and DO3 outputs: see chap. [8.14](#).

→ Wire the output DO4 as described in [Fig. 39](#), chap. [10.6.1](#).

→ Start the device again.

→ Configure the device with the dosing mode "LOC. MEM." or "MEM.+MANU.": see chap. [10.7.7](#) or [10.7.8](#).

→ Do a dosing as shown in [Fig. 42](#).



- If the generation of alarms (alarm "DURING") for problems occurring during a dosing has been activated (see chap. 10.7.16), an alarm is generated if there is no flow rate measured in the pipe whereas the valves are open. See chap. 11.3.4 to solve the problem.
- If the generation of alarms (alarm "AFTER") for problems occurring at the end of the dosing has been activated (see chap. 10.7.17), an alarm is generated if there is still flow in the pipe whereas the valves are closed. See chap. 11.3.4 to solve the problem.

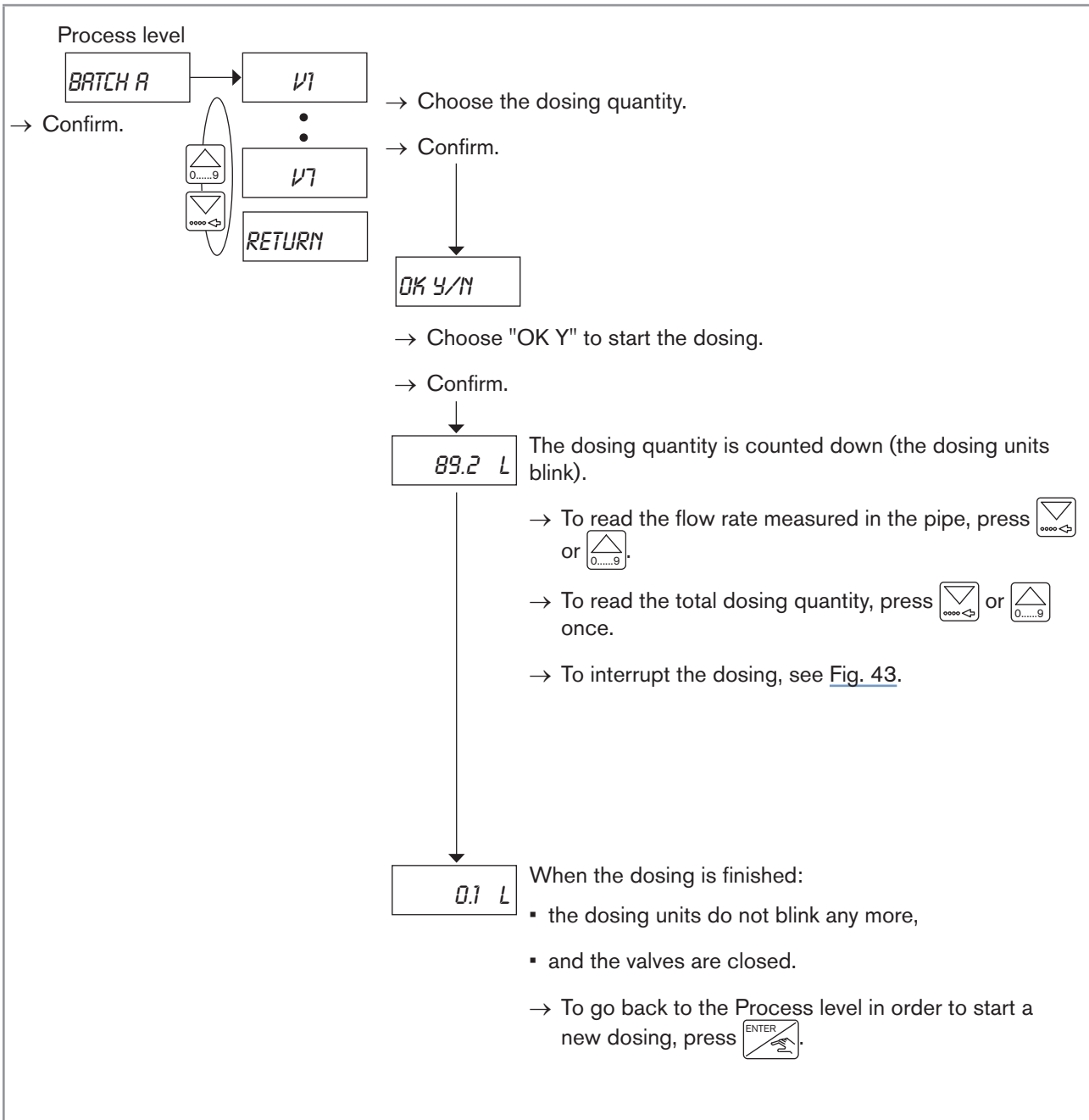

Fig. 42 : Doing a dosing in dosing modes "LOC. MEM." or "MEM.+MANU."

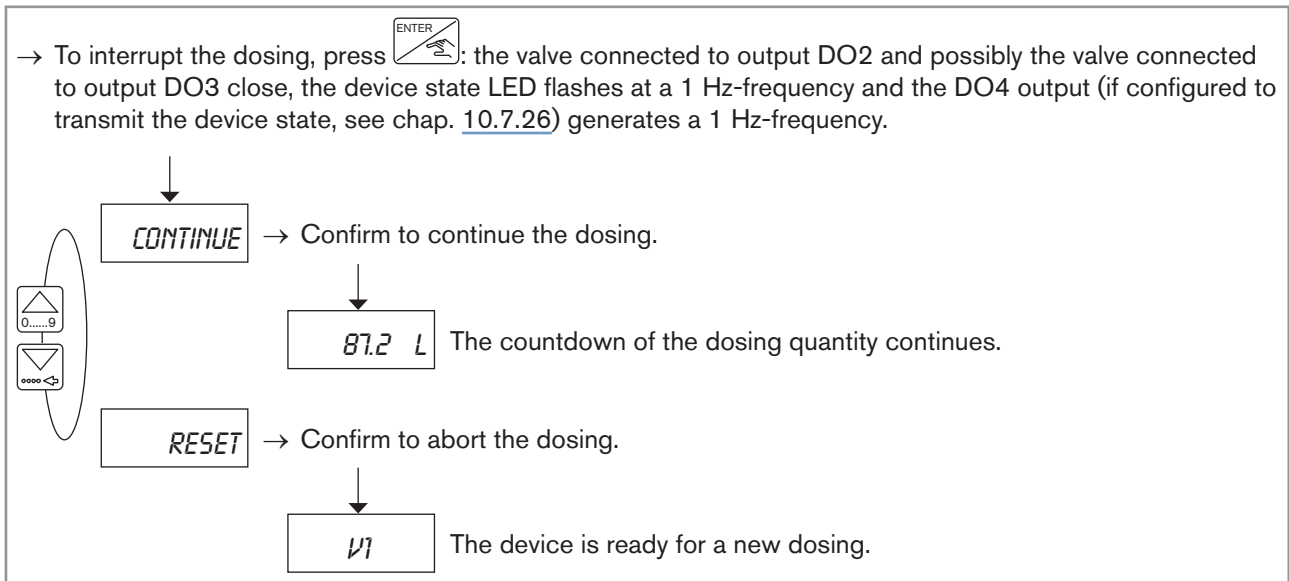

Fig. 43 : Interrupting the dosing in dosing modes "LOC. MEM." or "MEM.+MANU."

10.6.3 Doing a dosing in dosing mode "EXT. MEM."

Dosing mode "EXT. MEM" allows for selecting a dosing quantity from the device memory and starting the dosing, via the digital inputs.



DANGER

Danger due to electrical voltage.

- ▶ Disconnect the electrical power for all the conductors and isolate it before carrying out work on the system.
- ▶ Observe all applicable accident protection and safety regulations for electrical equipment.

→ Connect the valves to the DO2 and DO3 outputs: see chap. 8.14.

→ Wire the output DO4 and the digital inputs DI1 to DI4 as described in Fig. 44 and depending on the following requirements:

- the transistor output DO4 allows for transmitting the dosing state if the output DO4 is configured with the function "STATE" (see chap. 10.7.26).
- the digital input DI4 allows for starting, interrupting, continuing or aborting a dosing. It also allows for confirming an alarm, if the generation of alarms has been activated on the device (see chap. 10.7.16 and 10.7.17).
- the digital inputs DI1 to DI3 allow for selecting one of the 7 dosing quantities stored in the memory of the device. If all the 7 dosing quantities are not used, only connect the necessary inputs. When a dosing has been interrupted, the digital inputs allow for the navigation within the pause menu, between the function "CONTINUE" and the function "RESET".

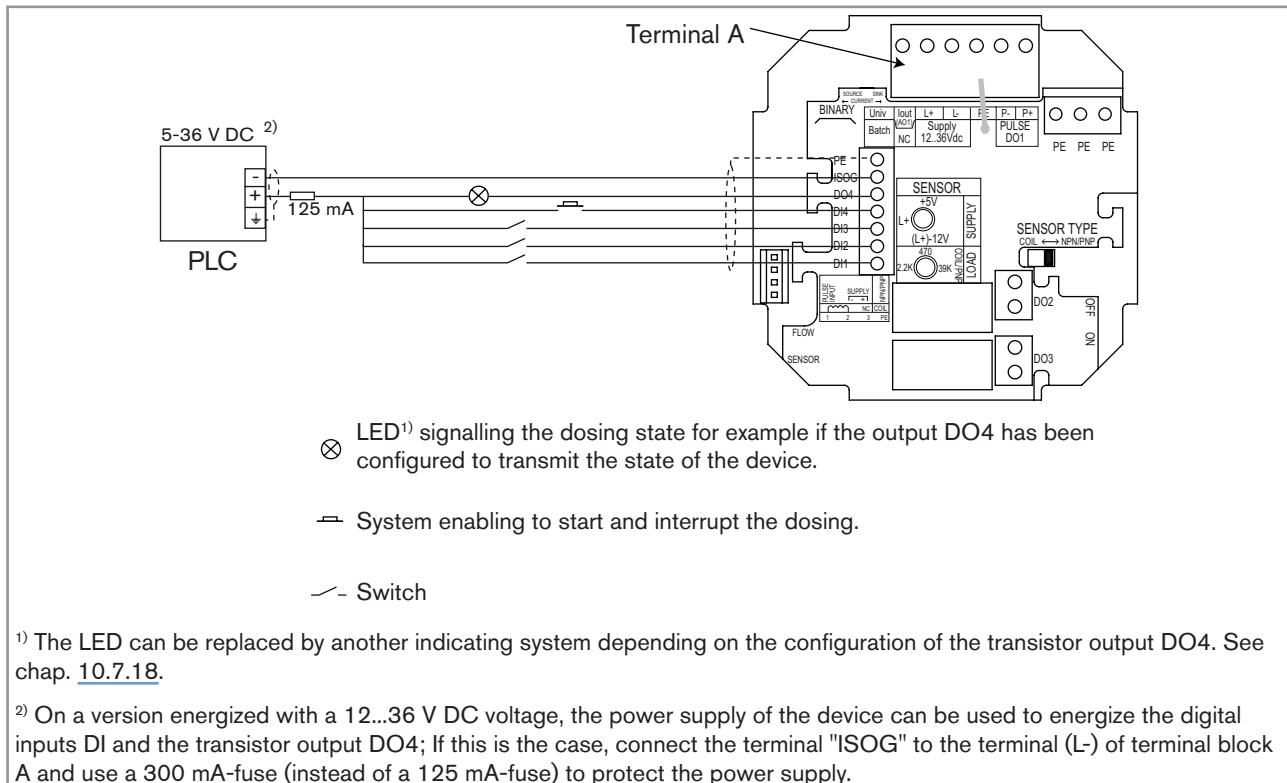

Fig. 44 : Electrical connection of the digital inputs DI and of the transistor output DO4 in dosing modes "EXT. MEM", "EXT. +LOC" or "EXT. [T]"

→ Restart the device:

- If the DI4 input is at the low level (not powered) when energizing the device, the four digital inputs will be active at high level.
- If the DI4 input is at the high level (not powered) when energizing the device, the four digital inputs will be active at low level.

→ Configure the device with this dosing mode: see chap. [10.7.9](#).

→ Do a dosing as shown in [Fig. 45](#).



- If the generation of alarms (alarm "DURING") for problems occurring during a dosing has been activated (see chap. [10.7.16](#)), an alarm is generated if there is no flow rate measured in the pipe whereas the valves are open. See chap. [11.3.4](#) to solve the problem.
- If the generation of alarms (alarm "AFTER") for problems occurring at the end of the dosing has been activated (see chap. [10.7.17](#)), an alarm is generated if there is still flow in the pipe whereas the valves are closed. See chap. [11.3.4](#) to solve the problem.

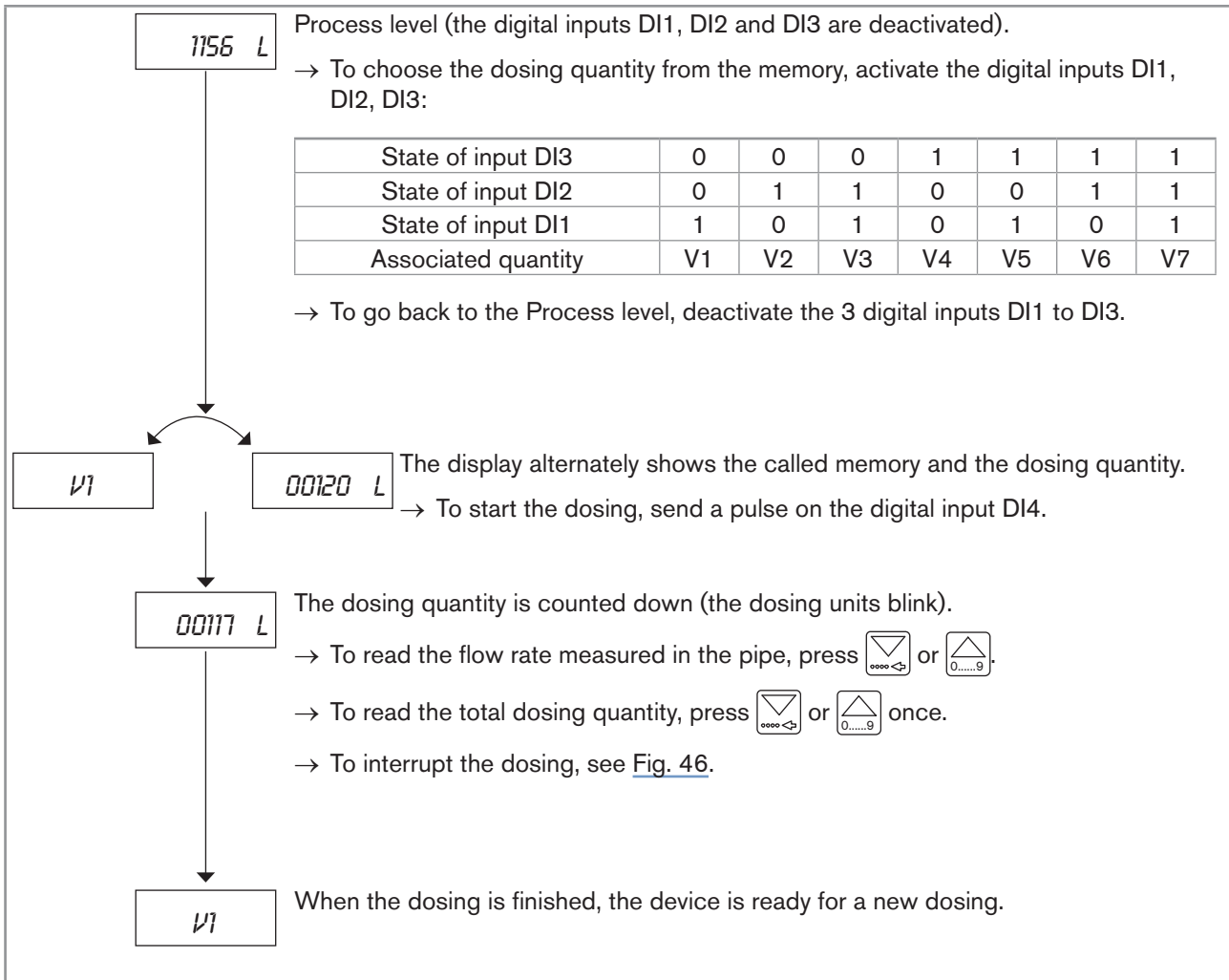



Fig. 45 : Doing a dosing of a quantity from the memory, in dosing mode "EXT. MEM."

MAN 1000199281 EN Version: C Status: RL (released | freigegeben) printed: 22.09.2017

→ To interrupt the dosing, press : the valve connected to output DO2 and possibly the valve connected to output DO3 close, the device state LED flashes at a 1 Hz-frequency and the DO4 output (if configured to transmit the device state, see chap. 10.7.26) generates a 1 Hz-frequency.

↓

CONTINUE → To continue the dosing via the digital inputs:

- let at least one of the 3 digital inputs, DI1, DI2 or DI3, activated
- then send a pulse on DI4.

→ To continue the dosing via the navigation keys, if at least one of the 3 digital inputs, DI1, DI2 or DI3 is activated:

- display "CONTINUE" by pressing key  or ,
- then press key .

↓

113 L The countdown of the dosing quantity continues.

RESET → To abort the dosing via the digital inputs:

- deactivate the 3 digital inputs, DI1, DI2 and DI3,
- then send a pulse on DI4.

→ To abort the dosing via the navigation keys, if at least one of the 3 digital inputs, DI1, DI2 or DI3 is activated:

- display "RESET" by pressing key  or ,
- then press key .

↓

11 The device is ready for a new dosing.

Fig. 46 : Interrupting the dosing, in dosing mode "EXT. MEM."

10.6.4 Doing a dosing in dosing mode "EXT.+LOC."

Dosing mode "EXT.+LOC." allows for:

- selecting a dosing quantity from the memory of the device, via the navigation keys or the digital inputs,
- then starting the dosing via the digital input DI4 (only).



DANGER

Danger due to electrical voltage.

- ▶ Disconnect the electrical power for all the conductors and isolate it before carrying out work on the system.
- ▶ Observe all applicable accident protection and safety regulations for electrical equipment.

→ Connect the valves to the DO2 and DO3 outputs: see chap. [8.14](#).

→ Wire the output DO4 and the digital inputs DI as described in [Fig. 44](#), chap. [10.6.3](#), and depending on the following requirements:

- the transistor output DO4 allows for transmitting the dosing state.
- the digital input DI4 allows for starting, interrupting, continuing or aborting a dosing. It also allows for confirming an alarm, if the generation of alarms has been activated on the device (see chap. [10.7.16](#) and [10.7.17](#)).
- the digital inputs DI1 to DI3 allow for selecting one of the 7 dosing quantities, entered into the device memory (see [Fig. 45](#), chap. [10.6.3](#)). If all the 7 dosing quantities are not used, only connect the necessary inputs. When a dosing has been interrupted, the digital inputs allow for the navigation within the pause menu, between the function "CONTINUE" and the function "RESET". If the dosing quantity is selected via the navigation keys and no dosing will be remotely aborted, inputs DI1 to DI3 can be left unconnected.

→ Restart the device:

- If the DI4 input is at the low level (not powered) when energizing the device, the four digital inputs will be active at high level.
- If the DI4 input is at the high level (not powered) when energizing the device, the four digital inputs will be active at low level.

→ Configure the device with this dosing mode: see chap. [10.7.10](#).

→ Do the dosing of a quantity stored in the memory and selected with the navigation keys, see [Fig. 47](#).

→ Do the dosing of a quantity stored in the memory via the digital inputs, see [Fig. 48](#).



- If the generation of alarms (alarm "DURING") for problems occurring during a dosing has been activated (see chap. [10.7.16](#)), an alarm is generated if there is no flow rate measured in the pipe whereas the valves are open. See chap. [11.3.4](#) to solve the problem.
- If the generation of alarms (alarm "AFTER") for problems occurring at the end of the dosing has been activated (see chap. [10.7.17](#)), an alarm is generated if there is still flow in the pipe whereas the valves are closed. See chap. [11.3.4](#) to solve the problem.



- To select the dosing quantity via the navigation keys, deactivate the 3 digital inputs DI1 to DI3.
- If a warning message is generated by the device and no dosing is being done, a long pulse (> 2 seconds) on DI4 allows for remotely accessing to the Information menu, whatever the state of the inputs DI1 to DI3. See chap. 10.11.

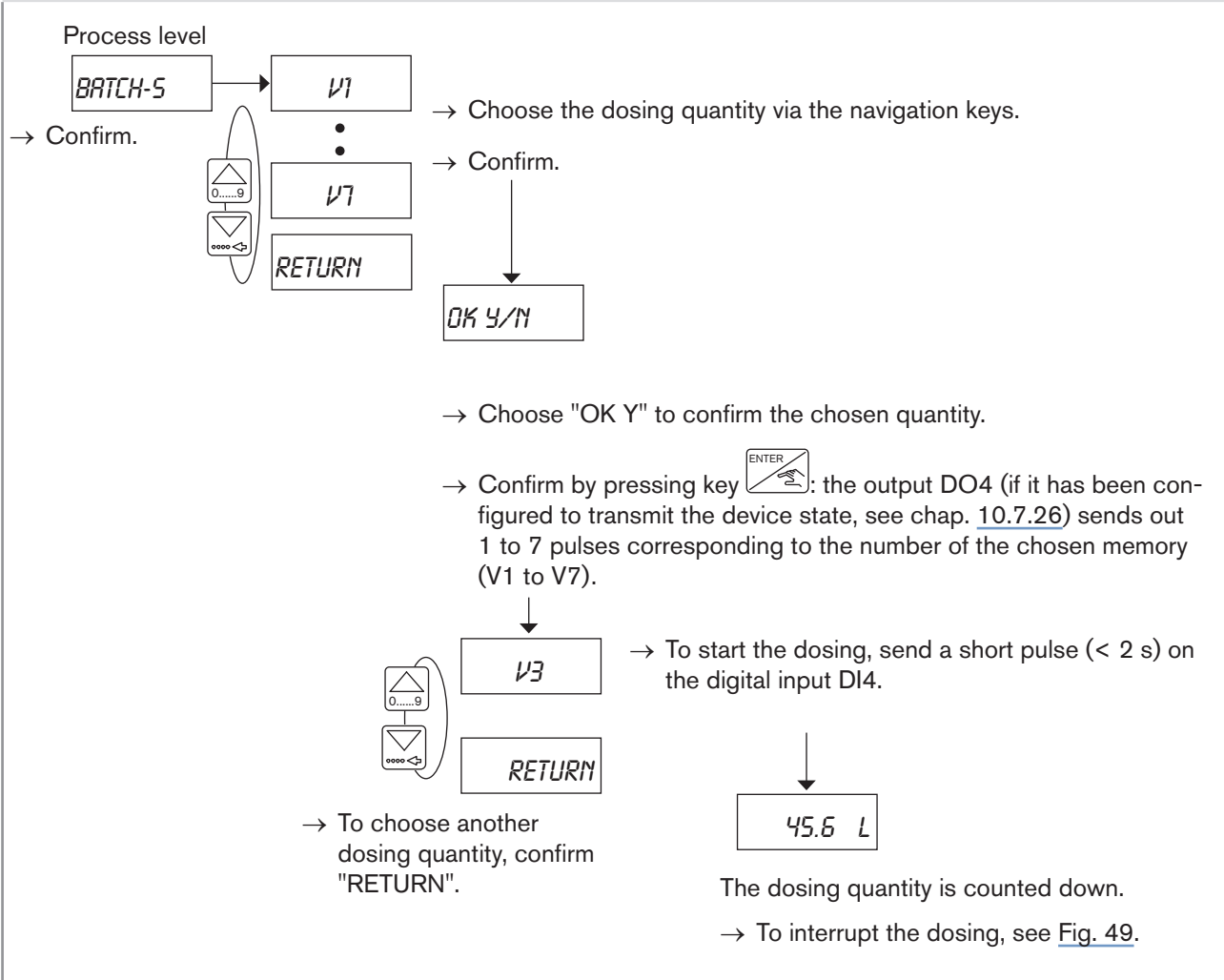

Fig. 47 : Doing the dosing of a quantity from the device memory via the navigation keys and the digital input DI4, in dosing mode "EXT.+LOC."



If a warning message is generated by the device and no dosing is being done, a long pulse (> 2 seconds) on DI4 allows for remotely accessing to the Information menu, whatever the state of the inputs DI1 to DI3. See chap. 10.11.

1156 L

Process level (the digital inputs DI1, DI2 and DI3 are deactivated).

→ To choose the dosing quantity from the memory, activate the digital inputs DI1, DI2, DI3:

State of input DI3	0	0	0	1	1	1	1
State of input DI2	0	1	1	0	0	1	1
State of input DI1	1	0	1	0	1	0	1
Associated quantity	V1	V2	V3	V4	V5	V6	V7

→ To go back to the Process level, deactivate the 3 digital inputs DI1 to DI3.

V1

0120.0 L

The display alternately shows the called memory and the dosing quantity.

→ To start the dosing, send a short pulse (< 2 s) on the digital input DI4.

37.8L

The dosing quantity is counted down (the dosing units blink).

→ To read the flow rate measured in the pipe, press or .

→ To read the total dosing quantity, press or once.

→ To interrupt the dosing, see Fig. 46.

V1

When the dosing is finished, the device is ready for a new dosing.

→ To go back to the Process level, deactivate the 3 digital inputs DI1 to DI3.

Fig. 48 : Doing a dosing of a quantity from the memory via the digital inputs, in dosing mode "EXT.+LOC."

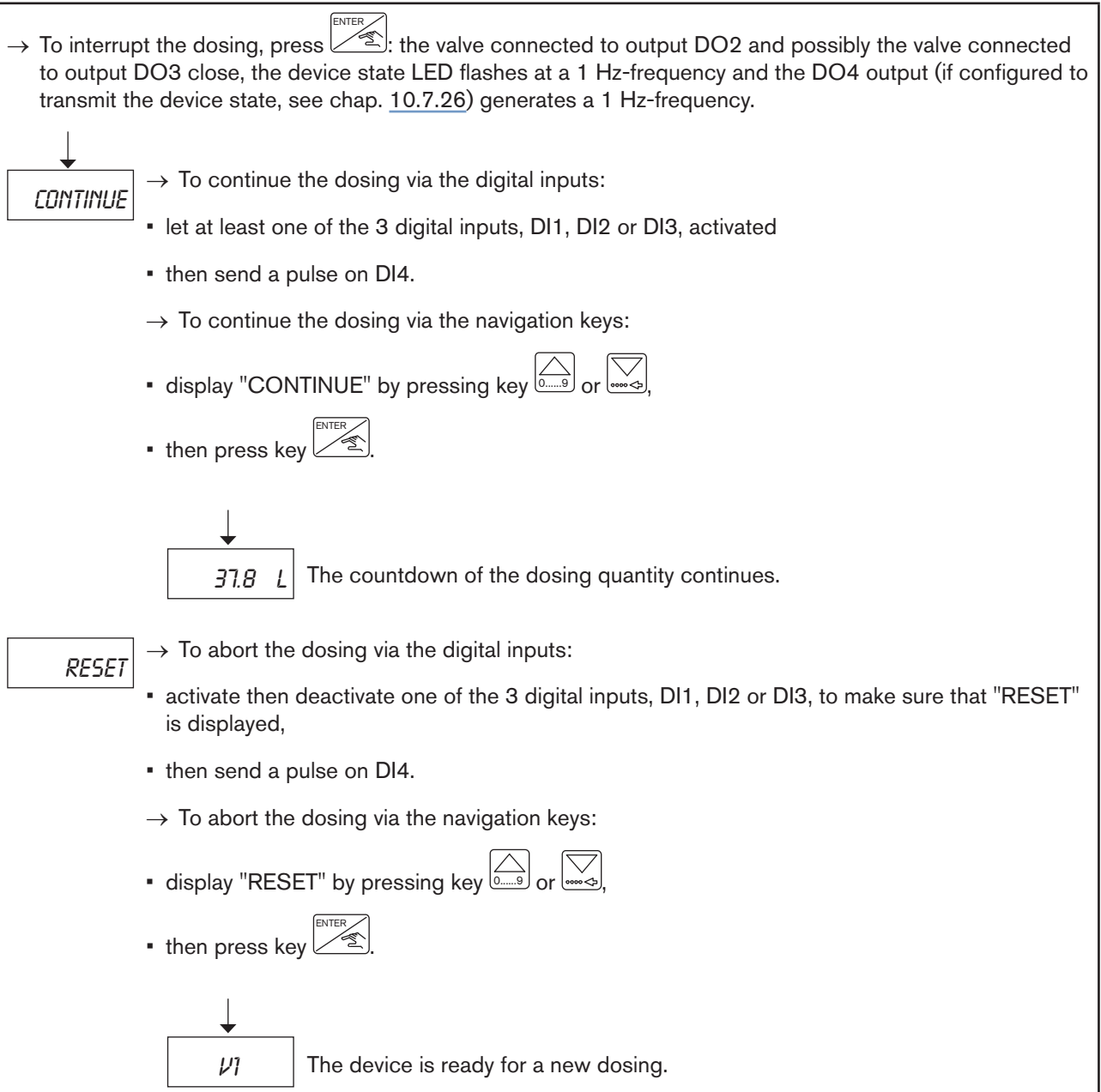

Fig. 49 : Interrupting the dosing, in dosing mode "EXT.+LOC."

10.6.5 Doing a dosing in dosing mode "EXT. [T]"



In this mode, the dosing starts as soon as the digital input DI1 is switched.

The dosing mode "EXT. [T]" allows for starting the dosing of a quantity proportional to the duration the digital input DI1 is activated.



DANGER

Danger due to electrical voltage.

- ▶ Disconnect the electrical power for all the conductors and isolate it before carrying out work on the system.
- ▶ Observe all applicable accident protection and safety regulations for electrical equipment.

→ Connect the valves to the DO2 and DO3 outputs: see chap. [8.14](#).

→ Wire the output DO4 and the digital inputs DI as described in [Fig. 44](#), chap. [10.6.3](#), and depending on the following requirements:

- the transistor output DO4 allows for transmitting the dosing state.
- the digital input DI1 allows for starting a dosing whose dosing quantity is proportional to the activation duration of DI1.
- the digital input DI4 allows for interrupting or continuing a dosing. It also allows for confirming an alarm, if the generation of alarms has been activated on the device (see chap. [10.7.16](#) and [10.7.17](#)).
- when a dosing has been interrupted, the digital inputs DI2 and/or DI3 allow for the navigation within the pause menu, between the function "CONTINUE" and the function "RESET".

→ Restart the device:

- If the DI4 input is at the low level (not powered) when energizing the device, the four digital inputs will be active at high level.
- If the DI4 input is at the high level (not powered) when energizing the device, the four digital inputs will be active at low level.

→ Configure the device with this dosing mode: see chap. [10.7.11](#).

→ Do a dosing as shown in [Fig. 50](#).



- If the generation of alarms (alarm "DURING") for problems occurring during a dosing has been activated (see chap. [10.7.16](#)), an alarm is generated if there is no flow rate measured in the pipe whereas the valves are open. See chap. [11.3.4](#) to solve the problem.
- If the generation of alarms (alarm "AFTER") for problems occurring at the end of the dosing has been activated (see chap. [10.7.17](#)), an alarm is generated if there is still flow in the pipe whereas the valves are closed. See chap. [11.3.4](#) to solve the problem.



If the message "ERROR [T]" is displayed during a dosing, see chap. [11.3.4](#) and [10.7.11](#).

1156 L

Process level (the digital inputs DI1, DI2 and DI3 are deactivated).

- To start the dosing, activate the digital input DI1 for a duration T related to the dosing quantity.
- To interrupt the dosing, see [Fig. 51](#).

6.3206 L

The counter is incremented (the units blink).

- To read the flow rate measured in the pipe, press or .
- To read the total dosing quantity, press or once.

100.06 L

When the digital input DI1 is deactivated and the quantity proportional to the activation duration has been reached:

- the valves are closed,
- and the total dosed quantity is displayed (the dosing units do not blink any more).

Fig. 50 : Doing a dosing, in dosing mode "EXT. [T]"

The activation duration of the digital input DI1 is counted even if the dosing has been interrupted.

→ To interrupt the dosing, press : the valve connected to output DO2 and possibly the valve connected to output DO3 close, the device state LED flashes at a 1 Hz-frequency and the DO4 output (if configured to transmit the device state, see chap. 10.7.26) generates a 1 Hz-frequency.

↓
 → To continue the dosing via the digital inputs:

- let the digital inputs DI2 and DI3 deactivated,
- then send a pulse on DI4.

→ To continue the dosing via the navigation keys, when the digital inputs DI2 and DI3 are deactivated:

- display "CONTINUE" by pressing key or ,
- then press key .

↓
 The counting of the dosing quantity continues.

→ To abort the dosing via the digital inputs:

- activate one of the digital inputs DI2 or DI3,
- then send a pulse on DI4.

→ To abort the dosing via the navigation keys, when the inputs DI2 and DI3 are deactivated:

- display "RESET" by pressing key or ,
- then press key .

↓
 Process level: the device is ready for a new dosing.

Fig. 51 : Interrupting the dosing, in dosing mode "EXT. [T]"

10.6.6 Doing a dosing in dosing mode "EXT. REP."

The dosing mode "EXT. REP." allows for starting, via the digital inputs, the dosing of the quantity determined by a Teach-In procedure.

! DANGER

Danger due to electrical voltage.

- ▶ Disconnect the electrical power for all the conductors and isolate it before carrying out work on the system.
- ▶ Observe all applicable accident protection and safety regulations for electrical equipment.

→ Connect the valves to the DO2 and DO3 outputs: see chap. 8.14.

→ Wire the output DO4 and the digital inputs as described in Fig. 52 and depending on the following requirements:

- the transistor output DO4 allows for transmitting the dosing state.
- when a dosing has been interrupted, the digital input DI1 allows for the navigation within the pause menu, between the function "CONTINUE" and the function "RESET".
- the digital input DI4 allows for interrupting or continuing a dosing, when the digital input DI1 is active. It also allows for confirming an alarm, if the generation of alarms has been activated on the device (see chap. 10.7.16 and 10.7.17).

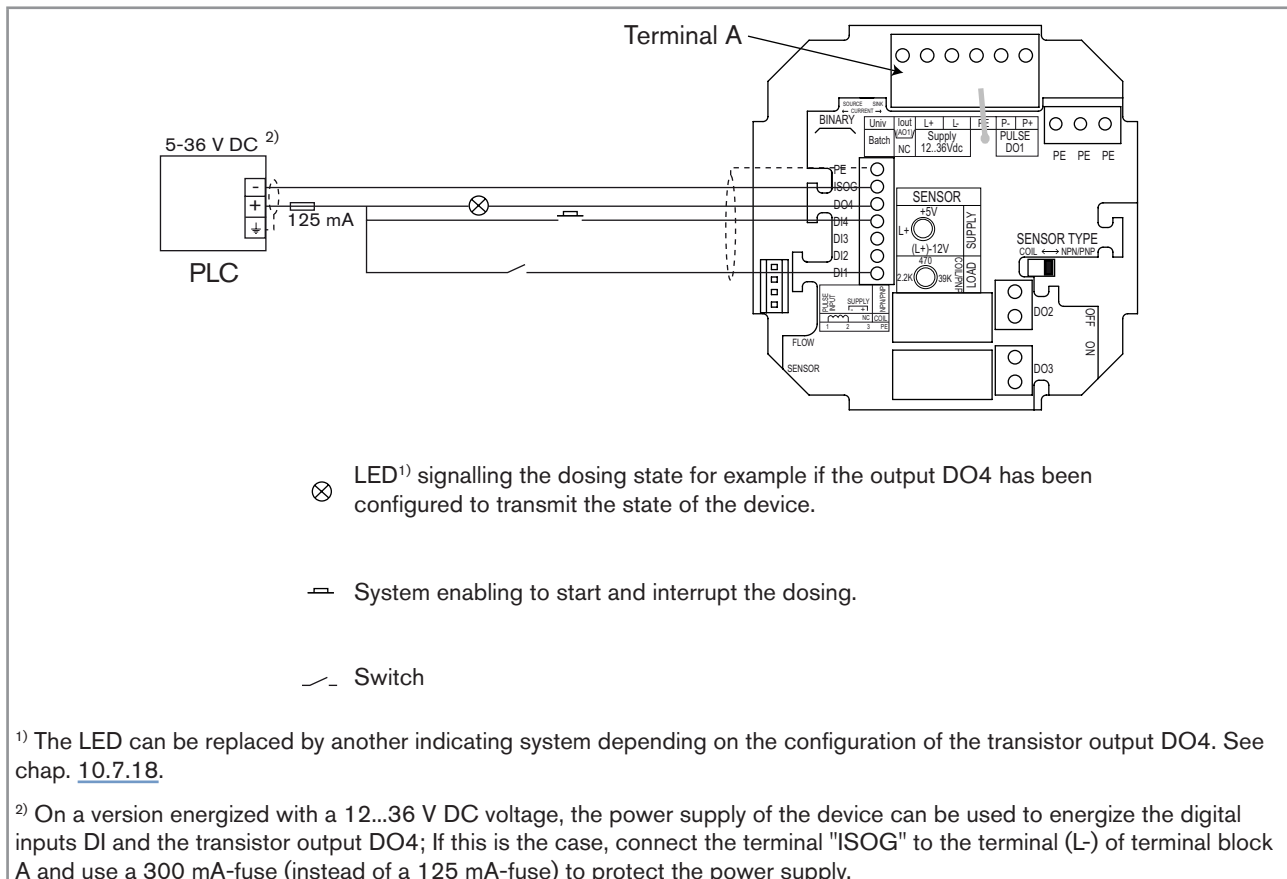

Fig. 52 : Electrical connection of the digital inputs DI and of the transistor output DO4 in the dosing mode "EXT. REP"

→ Restart the device:

- If the DI4 input is at the low level (not powered) when energizing the device, the four digital inputs will be active at high level.
- If the DI4 input is at the high level (not powered) when energizing the device, the four digital inputs will be active at low level.

→ Configure the device with this dosing mode, see chap. [10.7.12](#).

→ Do a dosing as shown in [Fig. 53](#).



- If the generation of alarms (alarm "DURING") for problems occurring during a dosing has been activated (see chap. [10.7.16](#)), an alarm is generated if there is no flow rate measured in the pipe whereas the valves are open. See chap. [11.3.4](#) to solve the problem.
- If the generation of alarms (alarm "AFTER") for problems occurring at the end of the dosing has been activated (see chap. [10.7.17](#)), an alarm is generated if there is still flow in the pipe whereas the valves are closed. See chap. [11.3.4](#) to solve the problem.
- If the digital input DI1 is active, no dosing has been started and no warning message has been generated by the device, a long pulse (> 2 s) on DI4 allows for accessing to the Information menu. See chap. [10.11](#).

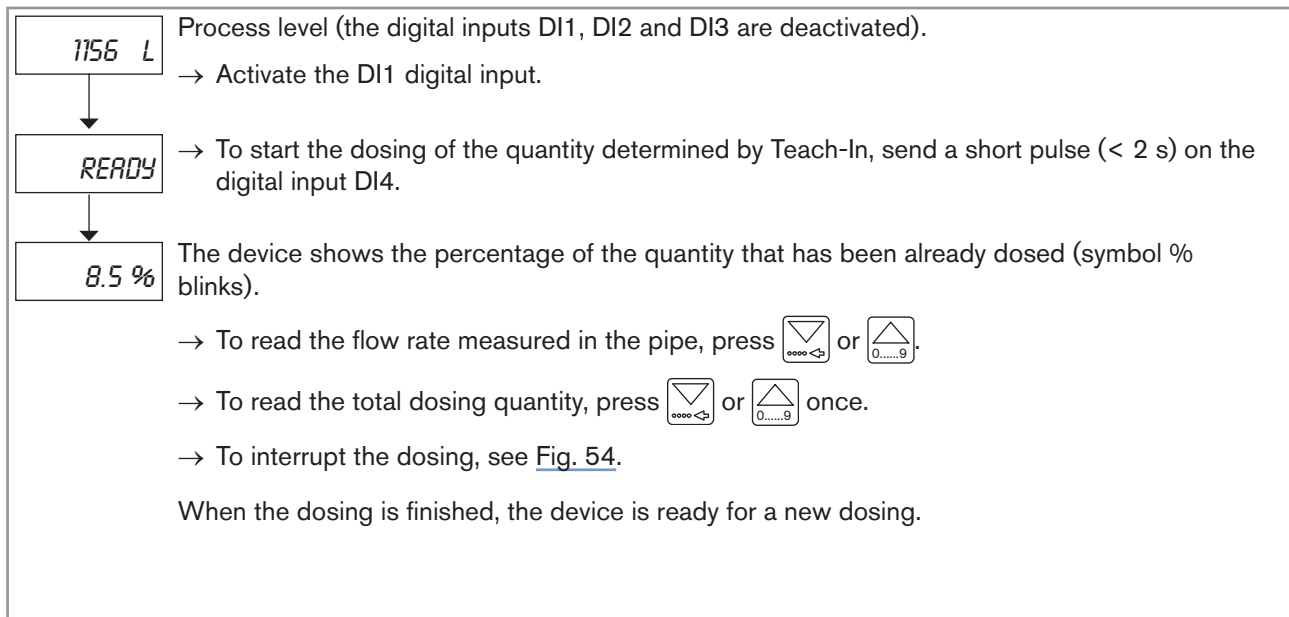



Fig. 53 : Doing a dosing, in dosing mode "EXT. REP."

→ To interrupt the dosing, press : the valve connected to output DO2 and possibly the valve connected to output DO3 close, the device state LED flashes at a 1 Hz-frequency and the DO4 output (if configured to transmit the device state, see chap. 10.7.26) generates a 1 Hz-frequency.

↓
CONTINUE → To continue the dosing via the digital inputs:

- Let the DI1 digital input activated.
- then send a pulse on DI4.

→ To continue the dosing via the navigation keys, when the digital input DI1 is activated:

- display "CONTINUE" by pressing key  or ,
- then press key .

↓
10.5 % The counting of the dosing quantity continues.

RESET → To abort the dosing via the digital inputs:

- Deactivate the DI1 digital input.
- then send a pulse on DI4.

→ To abort the dosing via the navigation keys, when the digital input DI1 is activated:

- display "RESET" by pressing key  or ,
- then press key .

↓
Process level: the device is ready for a new dosing.

Fig. 54 : Interrupting the dosing, in dosing mode "EXT. REP."

10.6.7 Doing a dosing in dosing mode "LOC. REP."

The dosing mode "LOC. REP." allows for starting, via the navigation keys, the dosing of the quantity determined by a Teach-In procedure.



DANGER

Danger due to electrical voltage.

- ▶ Disconnect the electrical power for all the conductors and isolate it before carrying out work on the system.
- ▶ Observe all applicable accident protection and safety regulations for electrical equipment.

- Wire the output DO4 as described in [Fig. 39](#).
- Connect the valves to the DO2 and DO3 outputs: see chap. [8.14](#).
- Start the device again.
- Configure the device with this dosing mode: see chap. [10.7.13](#).
- Do a dosing as shown in [Fig. 55](#).



- If the generation of alarms (alarm "DURING") for problems occurring during a dosing has been activated (see chap. [10.7.16](#)), an alarm is generated if there is no flow rate measured in the pipe whereas the valves are open. See chap. [11.3.4](#) to solve the problem.
- If the generation of alarms (alarm "AFTER") for problems occurring at the end of the dosing has been activated (see chap. [10.7.17](#)), an alarm is generated if there is still flow in the pipe whereas the valves are closed. See chap. [11.3.4](#) to solve the problem.

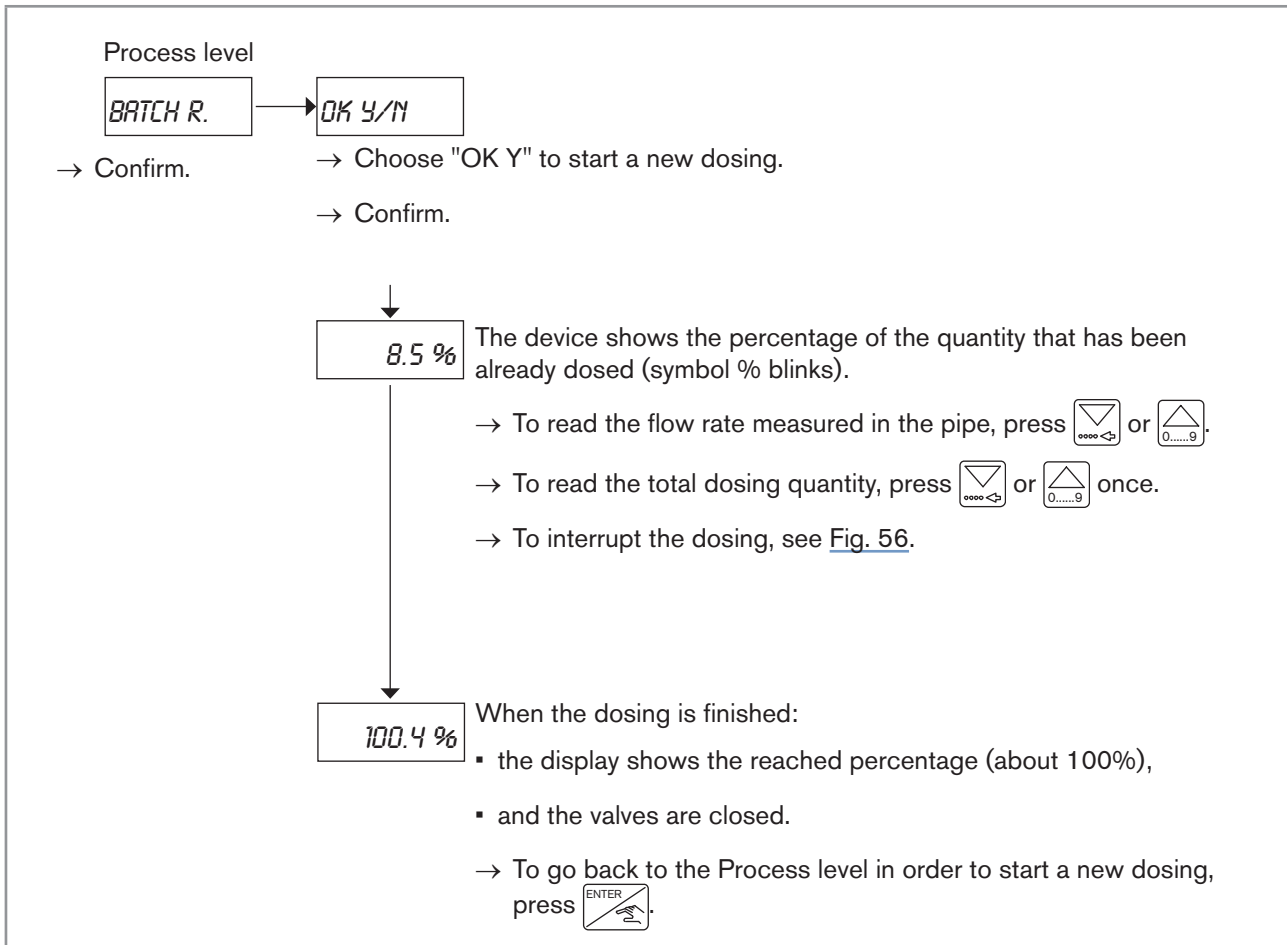

Fig. 55 : Doing a dosing, in dosing mode "LOC. REP."

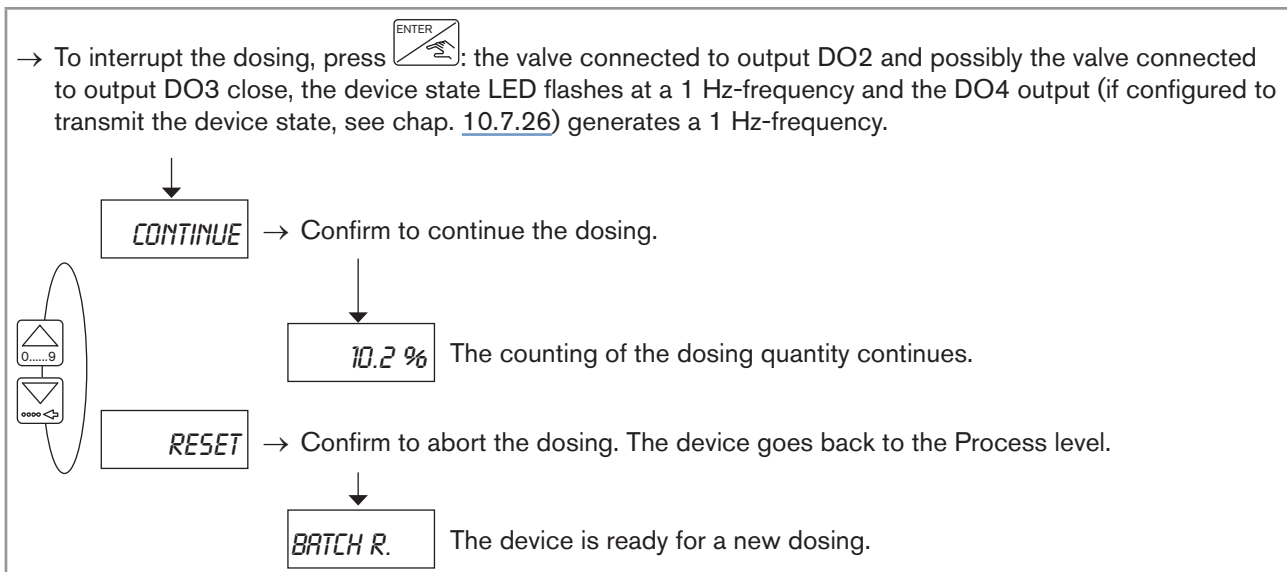





Fig. 56 : Interrupting the dosing, in dosing mode "LOC. REP."

10.7 Details of the Parameters menu

To access the Parameters menu, simultaneously press keys    for at least 5 s.

This menu comprises the following configurable parameters:

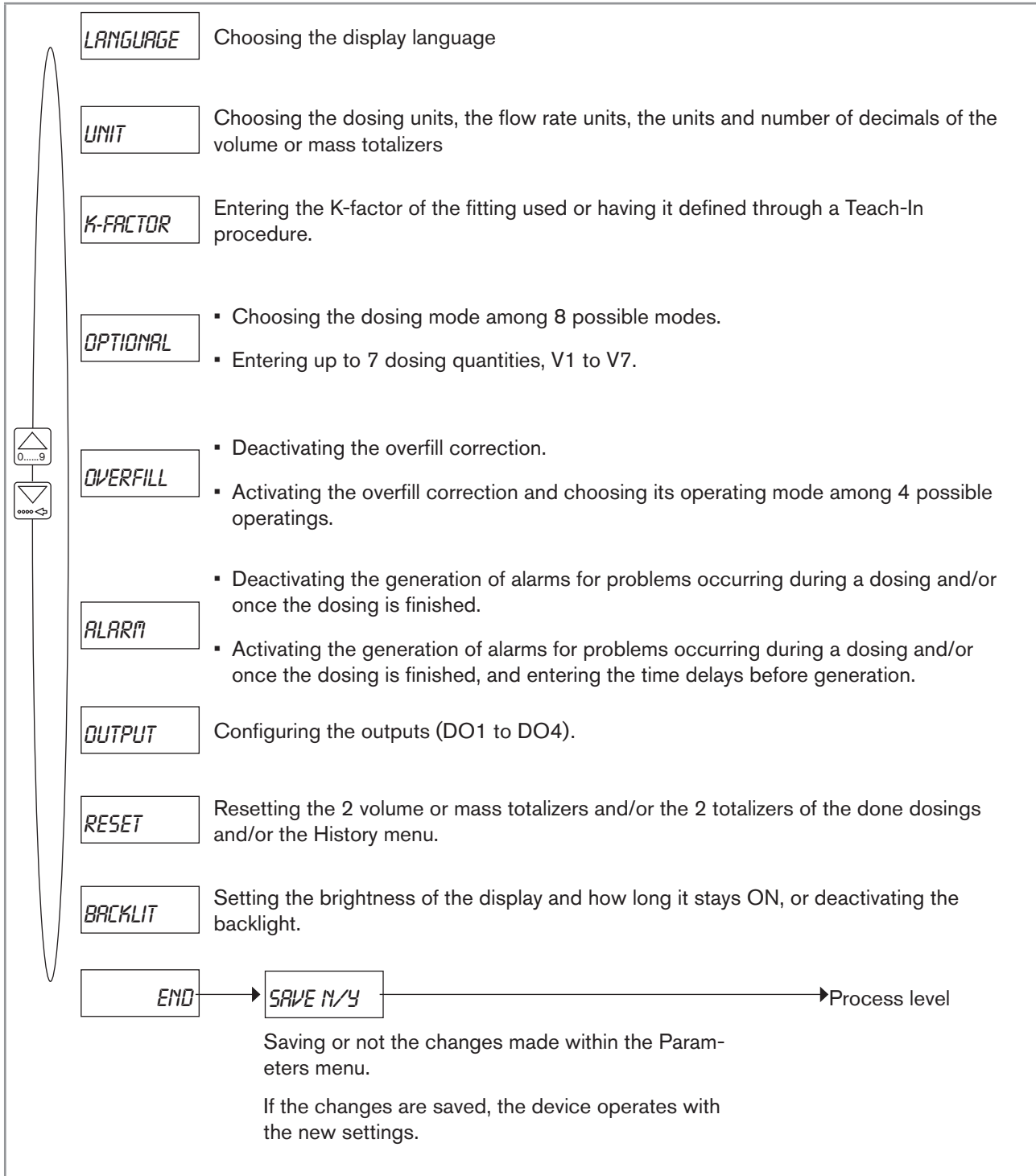

Fig. 57 : Diagram of the Parameters menu

10.7.1 Choosing the display language

When the device is energized for the first time, the display language is English.

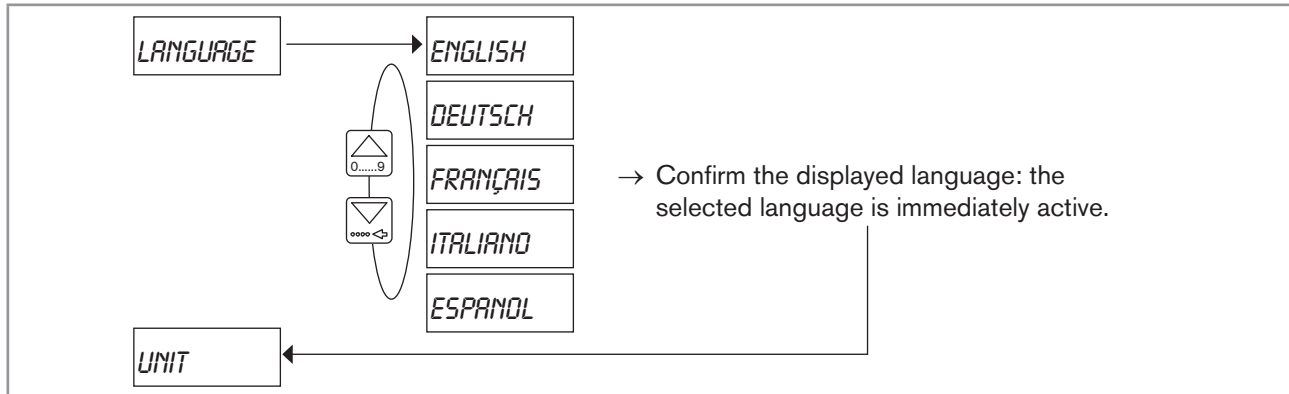



Fig. 58 : Diagram of the "LANGUAGE" parameter of the Parameters menu

→ If you do not want to adjust another parameter, go to the "END" parameter of the Parameters menu and press  to save the settings or not and go back to the Process level.

10.7.2 Choosing the dosing units, the flow rate units, the units and number of decimals of the volume or mass totalizers

When the units of the dosing quantities are changed:

- Reset both totalizers.
- Manually convert the volume or mass values in the different settings.



If, furthermore, the unit changes from "metric" to "gallon" and vice versa, convert the K-factor using following formulae:

- K-factor in pulse/US Gallon = K-factor in pulse/l x 3,785
- K-factor in pulse/IMP Gallon = K-factor in pulse/l x 4,546



If the dosing units chosen is a mass unit, convert the K-factor depending on the density of the fluid to measure.



The number of decimals of a dosing quantity is chosen when entering the quantity.

The "UNIT" parameter allows for choosing:

- the volume or mass units of the dosing quantities.
- the flow rate units (only used to display the flow measured during a dosing).
- the units of the volume totalizers if the dosing units previously chosen is in litres, millilitres or cubic-meters.
- a number of decimals (choice 0, 1 or 2) to display the volume or mass totalizers in the Process level.

MAN 1000199281 EN Version: C Status: RL (released | freigegeben) printed: 22.09.2017

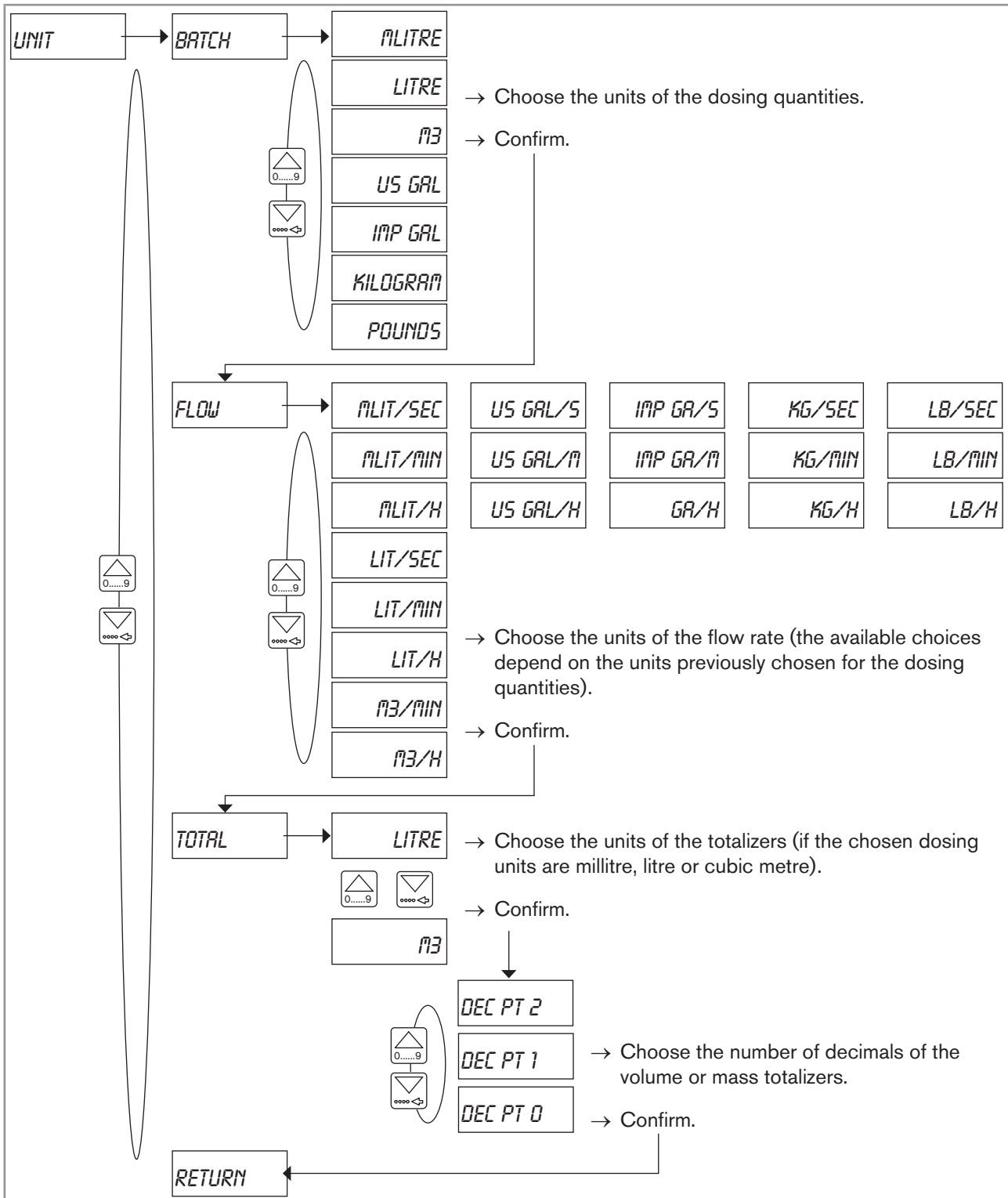

Fig. 59 : Diagram of the "UNIT" parameter of the Parameters menu

→ If you do not want to adjust another parameter, go to the "END" parameter of the Parameters menu and press to save the settings or not and go back to the Process level.

10.7.3 Entering the K-factor of the fitting used

The device determines the quantity of fluid that flows through the pipe using the fitting K-factor.

The K-factor of the fitting used can be entered here. The device may also determine the K-factor using a Teach-In procedure: see chap. 10.7.4.



The device uses the new K-factor as soon as "SAVE YES" is confirmed when leaving the Parameters menu.



The K-factor of the fitting used can be found within the operating instructions of the fitting.

The operating instructions of the Bürkert fittings can be found on the CD delivered with the device or on the internet at www.burkert.com

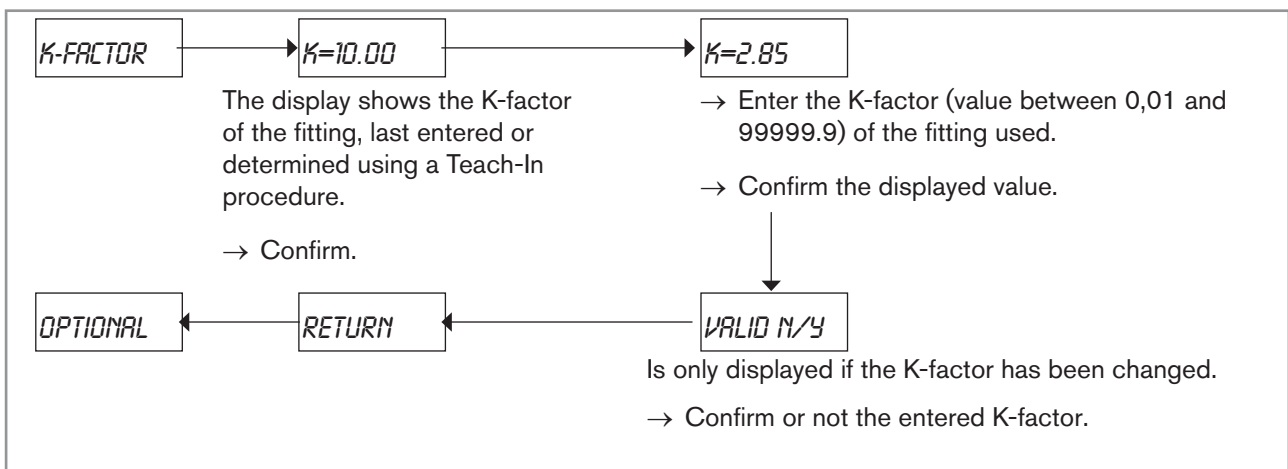



Fig. 60 : Entering the K-factor of the fitting used

→ If you do not want to adjust another parameter, go to the "END" parameter of the Parameters menu and press  to save the settings or not and go back to the Process level.

10.7.4 Determining the fitting K-factor using a Teach-In procedure

The device determines the flow rate in the pipe using the fitting K-factor.

The "TEACH V." or "TEACH F." parameter allows the device to determine the fitting K-factor using a Teach-In procedure. The K-factor may also be directly entered: see chap. 10.7.3.

The Teach-In can be done either depending on a known volume ("TEACH V.") or depending on the flow rate ("TEACH F.") in the pipe, measured by a reference instrument.

Determining the fitting K-factor using a Teach-In procedure depending on a volume ("TEACH V.")

- ! Before starting the Teach-In procedure, connect a valve to the relay output DO2.
- The device uses the new K-factor as soon as "SAVE YES" is confirmed when leaving the Parameters menu.

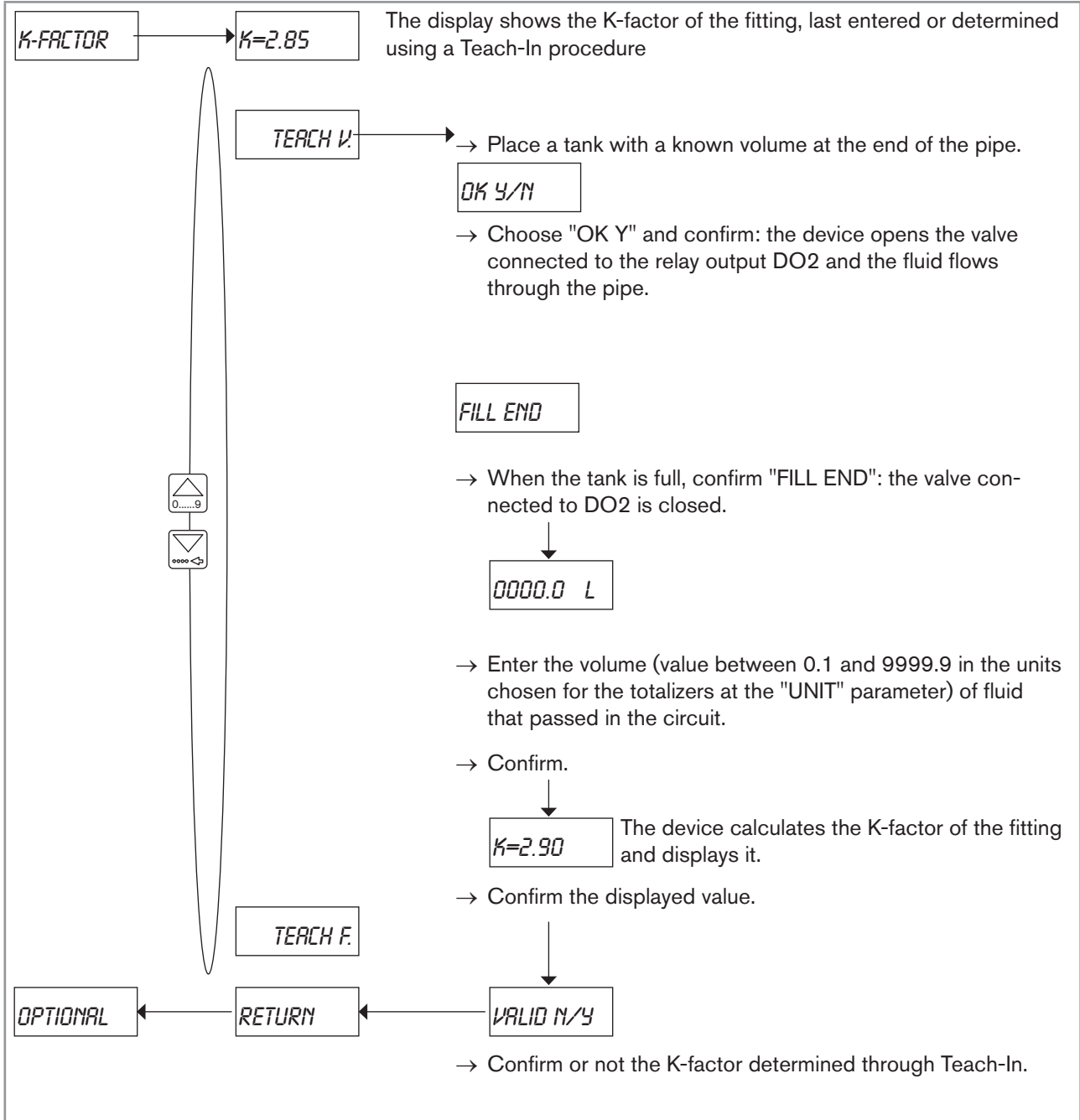



Fig. 61 : Teach-In procedure depending on a volume

→ If you do not want to adjust another parameter, go to the "END" parameter of the Parameters menu and press to save the settings or not and go back to the Process level.

MAN 1000199281 EN Version: C Status: RL (released | freigegeben) printed: 22.09.2017

Determining the fitting K-factor using a Teach-In procedure depending on a flow rate ("TEACH F.")

 The device uses the new K-factor as soon as "SAVE YES" is confirmed when leaving the Parameters menu.

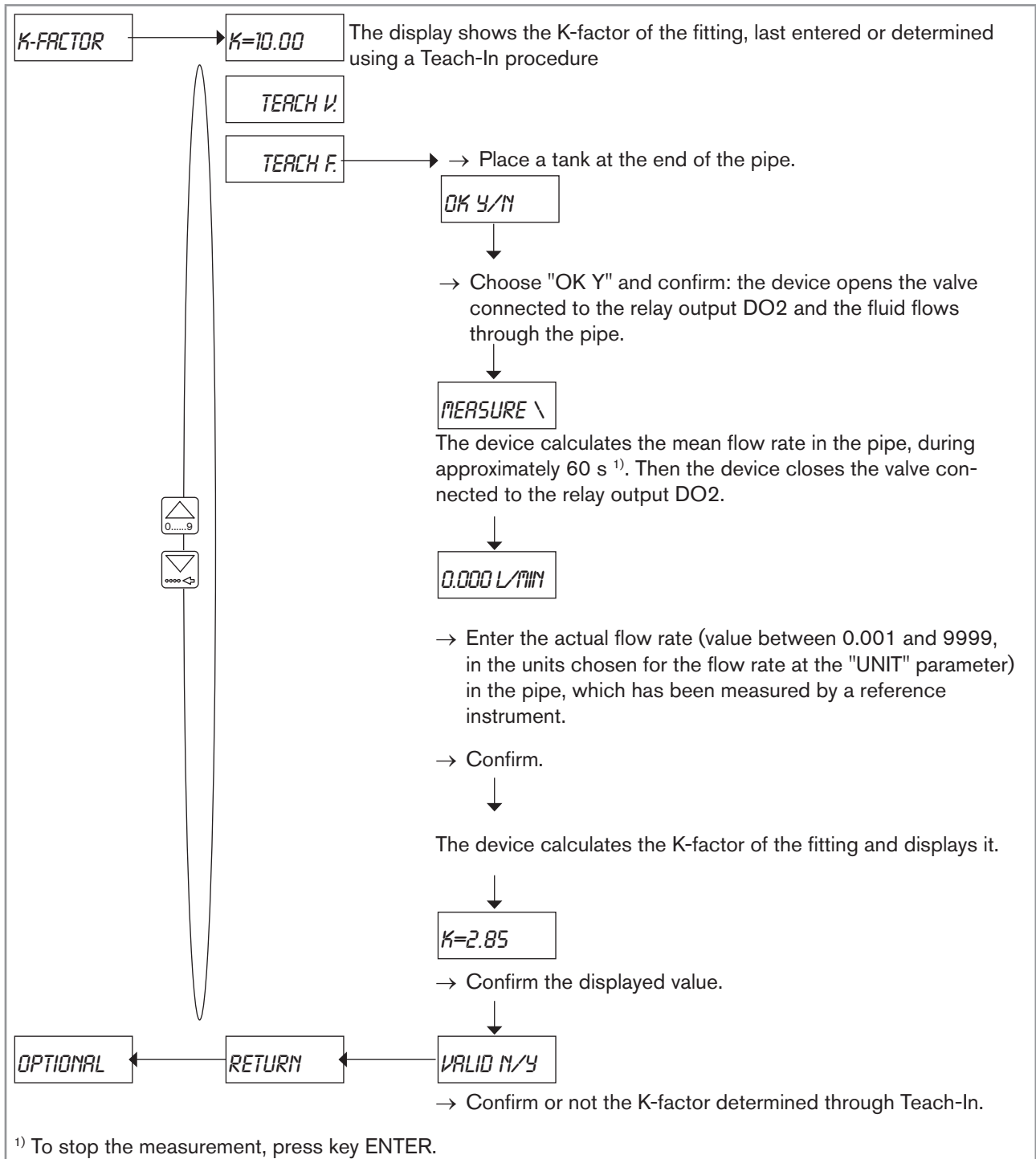

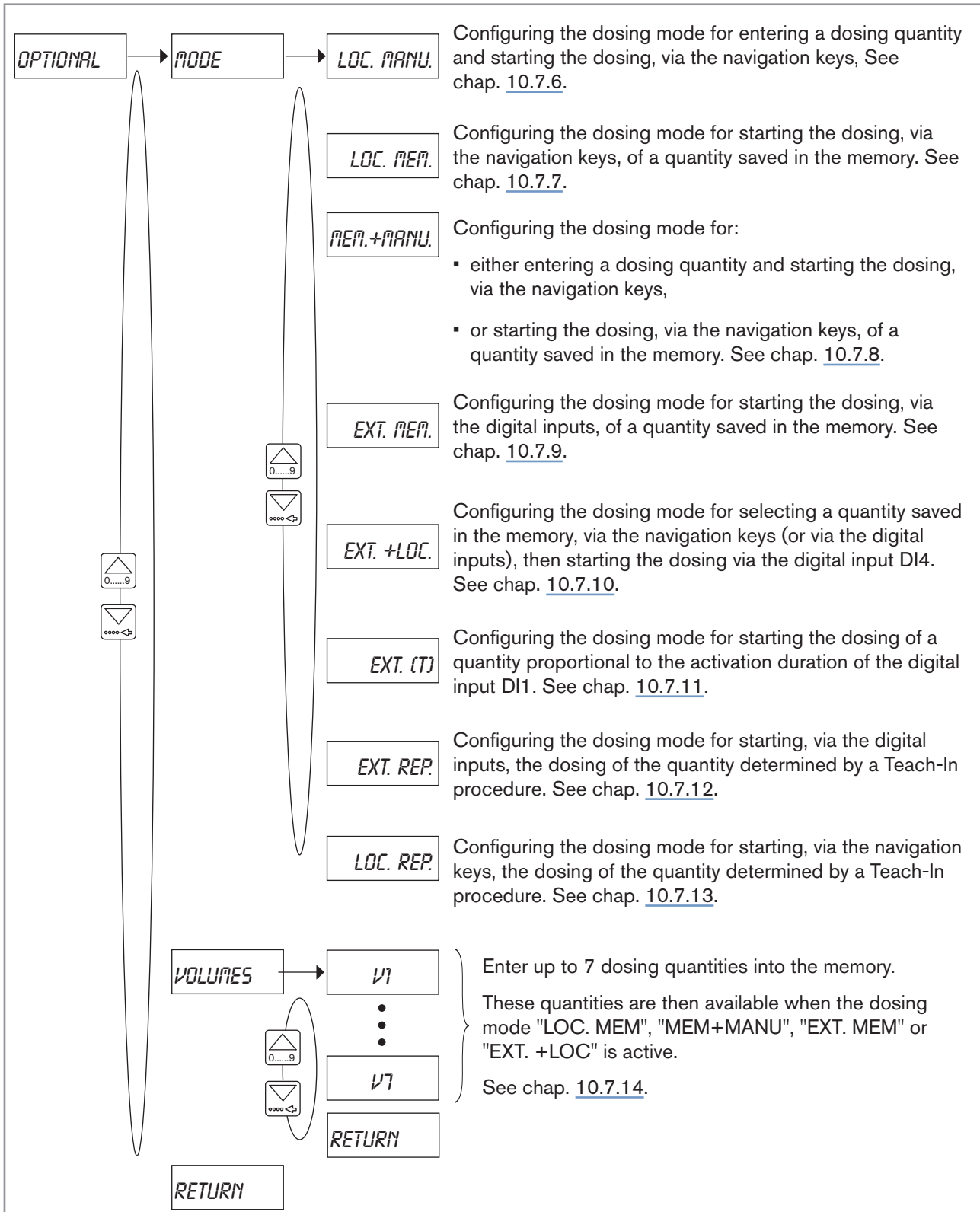

Fig. 62 : Teach-In procedure depending on the flow rate

→ If you do not want to adjust another parameter, go to the "END" parameter of the Parameters menu and press  to save the settings or not and go back to the Process level.

10.7.5 Configuring the dosing mode (general diagram)



MAN 1000199281 EN Version: C Status: RL (released | freigegeben) printed: 22.09.2017

Fig. 63 : Diagram of the "OPTIONAL" parameter of the Parameters menu

10.7.6 Configuring the dosing mode "LOC. MANU."

This dosing mode allows for entering a dosing quantity and starting the dosing, via the navigation keys.

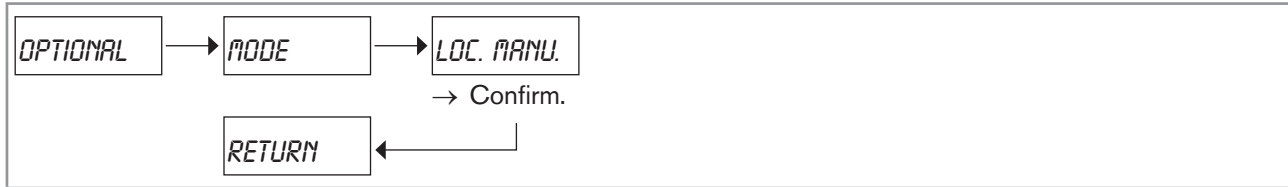



Fig. 64 : Configuring the dosing mode "LOC. MANU."

→ If you do not want to adjust another parameter, go to the "END" parameter of the Parameters menu and press  to save the settings or not and go back to the Process level.

10.7.7 Configuring the dosing mode "LOC. MEM."

This dosing mode allows for starting the dosing, via the navigation keys, of a quantity saved in the memory.

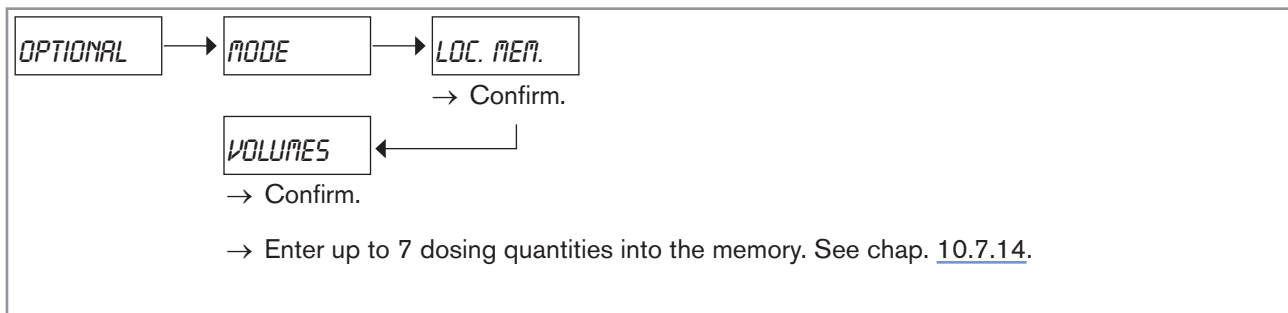



Fig. 65 : Configuring the dosing mode "LOC. MEM."

→ If you do not want to adjust another parameter, go to the "END" parameter of the Parameters menu and press  to save the settings or not and go back to the Process level.

10.7.8 Configuring the dosing mode "MEM+MANU"

This dosing mode allows for:

- either entering a dosing quantity and starting the dosing, via the navigation keys,
- or starting the dosing, via the navigation keys, of a quantity saved in the memory.

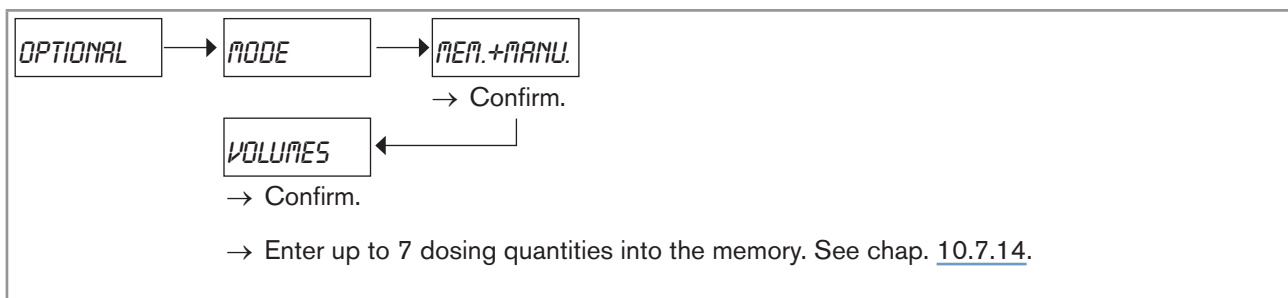



Fig. 66 : Configuring the dosing mode "MEM+MANU"

→ If you do not want to adjust another parameter, go to the "END" parameter of the Parameters menu and press  to save the settings or not and go back to the Process level.

10.7.9 Configuring the dosing mode "EXT. MEM."

This dosing mode allows for starting the dosing, via the digital inputs, of a quantity saved in the memory.

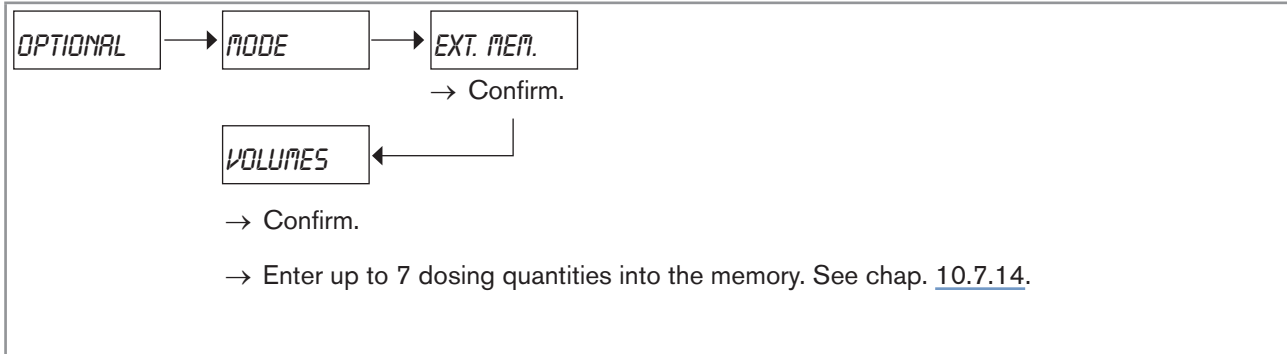



Fig. 67 : Configuring the dosing mode "EXT. MEM."

→ If you do not want to adjust another parameter, go to the "END" parameter of the Parameters menu and press  to save the settings or not and go back to the Process level.

10.7.10 Configuring the dosing mode "EXT. +LOC"

This dosing mode allows for selecting a quantity saved in the memory, via the navigation keys (or via the digital inputs), then starting the dosing via the digital input DI4.

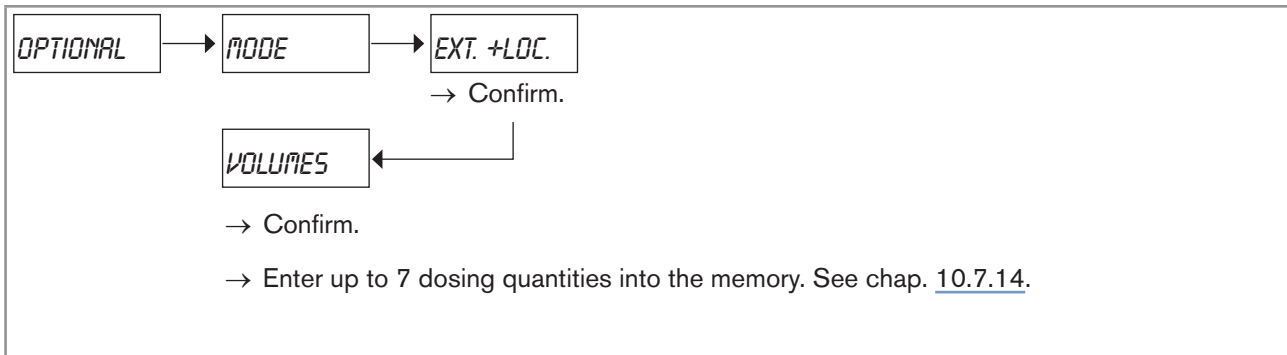



Fig. 68 : Configuring the dosing mode "EXT. +LOC."

→ If you do not want to adjust another parameter, go to the "END" parameter of the Parameters menu and press  to save the settings or not and go back to the Process level.

10.7.11 Configuring the dosing mode "EXT. [T]"



- In this mode, the dosing starts as soon as the digital input DI1 is switched.
- If the conditions for calculating A and B are not respected, an alarm ERROR [T] will be generated and the device will abort the current dosing.

This dosing mode allows for starting the dosing of a quantity proportional to the activation duration of the digital input DI1, according to the formula:

$$X = A \cdot T + B$$

- where A is the proportionality factor in dosing units per second,
- B is the offset in dosing units,
- X is the dosing quantity, in dosing units,
- and T is the activation duration of the digital input DI1, in seconds with a resolution of 5 ms.

→ Calculate constants A and B (see example in [Tab. 9](#)) in order:

- the activation duration "T" is within a time interval related to the process,
- the activation duration "T" is lower than the real filling duration, taking into account the flow rate in the pipe,
- (A*T + B) is always lower than 100 000 dosing units,
- (A*T + B) is higher than or equal to 6 divided by the set K-factor (in pulse/litre),
- the minimum activation duration (100 ms) is observed,
- the maximum activation duration (300 s) is observed,

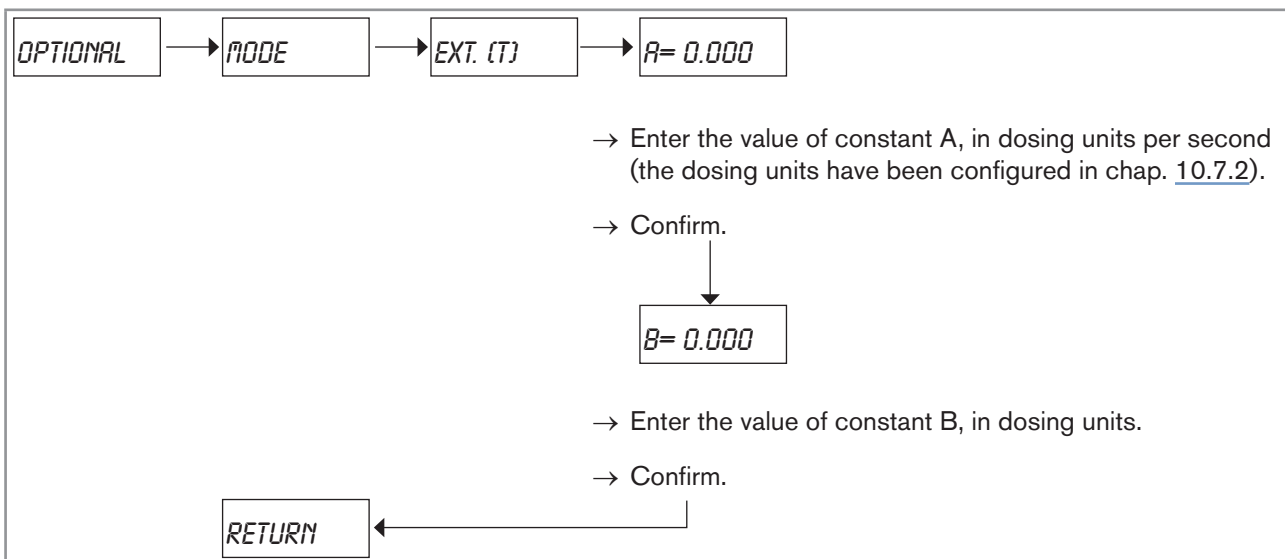



Fig. 69 : Configuring the dosing mode "EXT. [T]"

Tab. 9 : Calculation example of constants A and B

Dosing quantities	Required activation durations "T"	Value of constant A	Value of constant B
110 litres	2 seconds	5 l/s	100 litres
120 litres	4 seconds		
130 litres	6 seconds		
150 litres	10 seconds		

→ If you do not want to adjust another parameter, go to the "END" parameter of the Parameters menu and press  to save the settings or not and go back to the Process level.

10.7.12 Configuring the dosing mode "EXT. REP"

The dosing mode allows for starting, via the digital inputs, the dosing of the quantity determined by a Teach-In procedure.

Teach-In of the dosing quantity can be done either via the digital inputs or using the navigation keys.

With the Teach-In, the device automatically determines:

- the dosing quantity for each dosing made in dosing mode "EXT.REP." or "LOC. REP".
- the overfilling value to be corrected. If the overflow correction function is deactivated before the Teach-In is started, it will be automatically activated with the "DIRECT" option at the end of the Teach-In.
- the ratio of fluid that passes through each valve, if two valves are used.



Before starting the Teach-In procedure:

- Connect the valves to the DO2 and DO3 outputs: see chap. [8.14](#).
- Parameter the operating of and the time delay before the valve connected to the DO2 output is opened: see chap. [10.7.24](#).
- If two valves are used, configure output DO3 with the function "valve" and parameter the operating of the valve connected to the DO3 output: see chap. [10.7.25](#).



- If the generation of alarms (alarm "DURING") for problems occurring during a dosing has been activated (see chap. [10.7.16](#)), an alarm is generated if there is no flow rate measured in the pipe whereas the valves are open. See chap. [11.3.4](#) to solve the problem.
- If the generation of alarms (alarm "AFTER") for problems occurring at the end of the dosing has been activated (see chap. [10.7.17](#)), an alarm is generated if there is still flow in the pipe whereas the valves are closed. See chap. [11.3.4](#) to solve the problem.
- Do not anticipate the quantity of liquid that flows after the valves have been closed. Their closing must be controlled once the exact dosing quantity has been reached. The liquid surplus is measured and will be corrected in the next dosings.

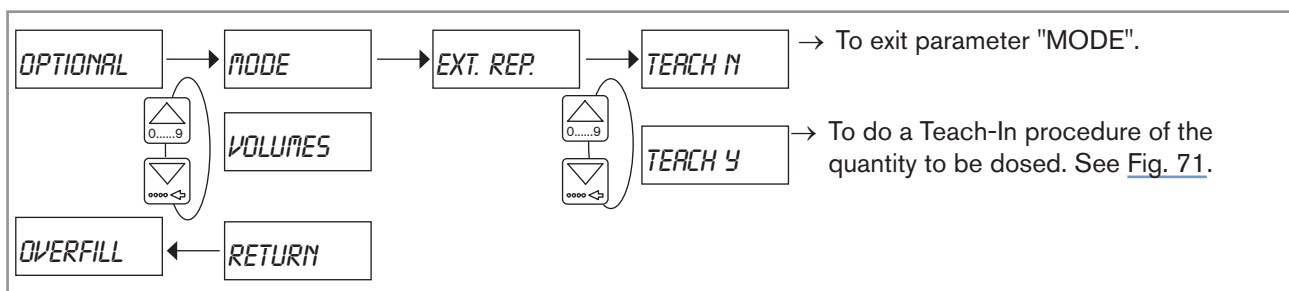

Fig. 70 : Configuring the dosing mode "EXT. REP."

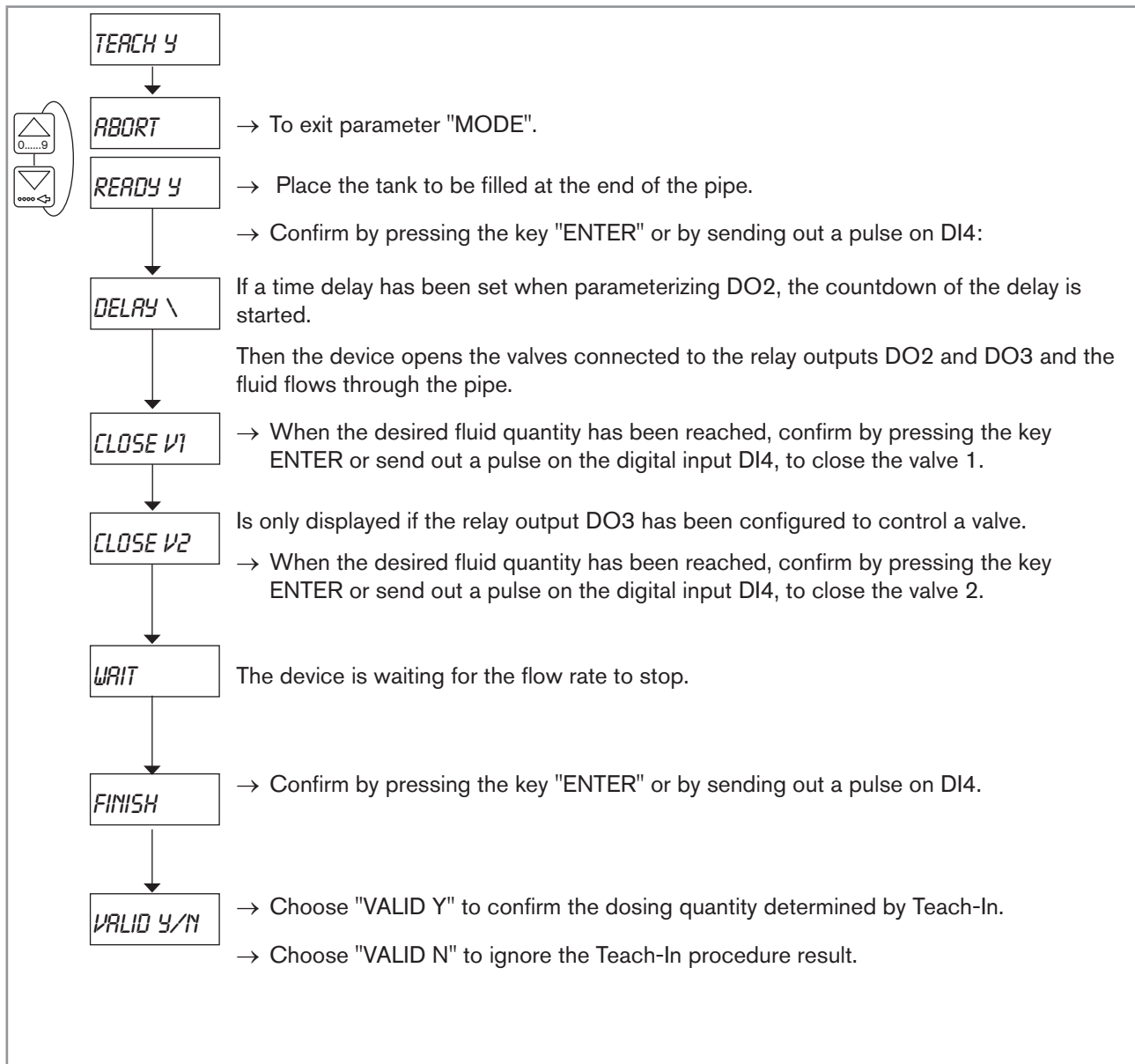



Fig. 71 : Determination of the dosing quantity using a Teach-In procedure

→ If you do not want to adjust another parameter, go to the "END" parameter of the Parameters menu and press  to save the settings or not and go back to the Process level.

10.7.13 Configuring the dosing mode "LOC. REP."

The dosing mode allows for starting, via the navigation keys, the dosing of the quantity determined by a Teach-In procedure.

Teach-In of the dosing quantity can be done either via the digital inputs or using the navigation keys.

With the Teach-In, the device automatically determines:

- the dosing quantity for each dosing made in dosing mode "EXT.REP." or "LOC. REP".
- the overfilling value to be corrected. If the overflow correction function is deactivated before the Teach-In is started, it will be automatically activated with the "DIRECT" option at the end of the Teach-In.
- the ratio of fluid that passes through each valve, if two valves are used.

! Before starting the Teach-In procedure:

- Connect the valves to the DO2 and DO3 outputs: see chap. [8.14](#).
- Parameter the operating of and the time delay before the valve connected to the DO2 output is opened: see chap. [10.7.24](#).
- If two valves are used, configure output DO3 with the function "valve" and parameter the operating of the valve connected to the DO3 output: see chap. [10.7.25](#).

!

- If the generation of alarms (alarm "DURING") for problems occurring during a dosing has been activated (see chap. [10.7.16](#)), an alarm is generated if there is no flow rate measured in the pipe whereas the valves are open. See chap. [11.3.4](#) to solve the problem.
- If the generation of alarms (alarm "AFTER") for problems occurring at the end of the dosing has been activated (see chap. [10.7.17](#)), an alarm is generated if there is still flow in the pipe whereas the valves are closed. See chap. [11.3.4](#) to solve the problem.
- Do not anticipate the quantity of liquid that flows after the valves have been closed. Their closing must be controlled once the exact dosing quantity has been reached. The liquid surplus is measured and will be corrected in the next dosings.

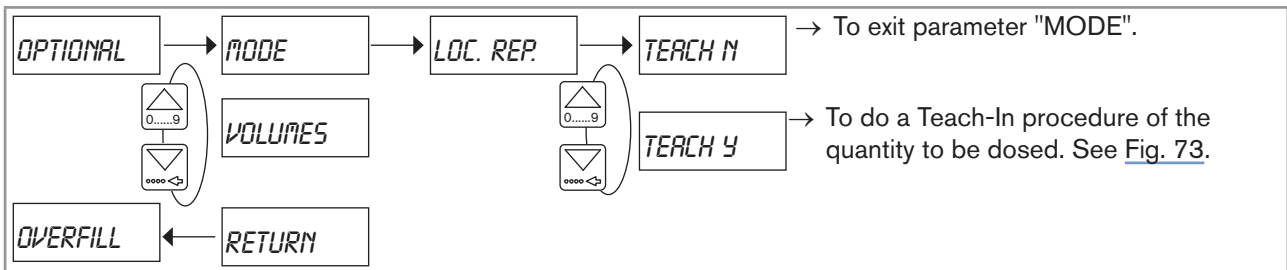

Fig. 72 : Configuring the dosing mode "LOC. REP."

MAN 1000199281 EN Version: C Status: RL (released | freigegeben) printed: 22.09.2017

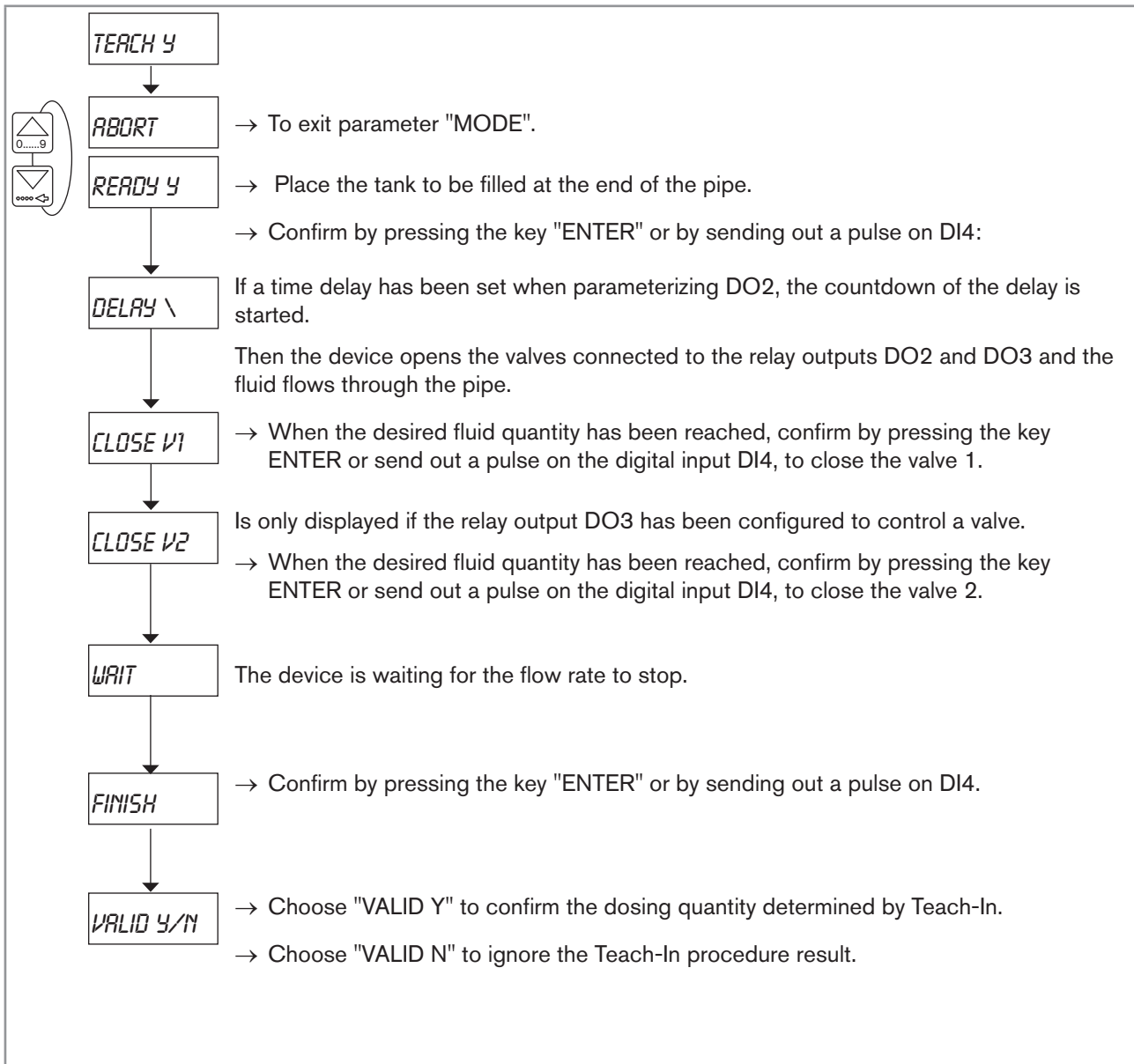

Fig. 73 : Determination of the dosing quantity using a Teach-In procedure

→ If you do not want to adjust another parameter, go to the "END" parameter of the Parameters menu and press



to save the settings or not and go back to the Process level.

10.7.14 Entering the dosing quantities in the device memory

The parameter "VOLUMES" of the sub-menu "OPTIONAL" allows for entering up to 7 dosing quantities in the device memory.

These quantities are then available when the dosing modes "LOC. MEM", "MEM+MANU", "EXT. MEM" or "EXT. +LOC" is active.

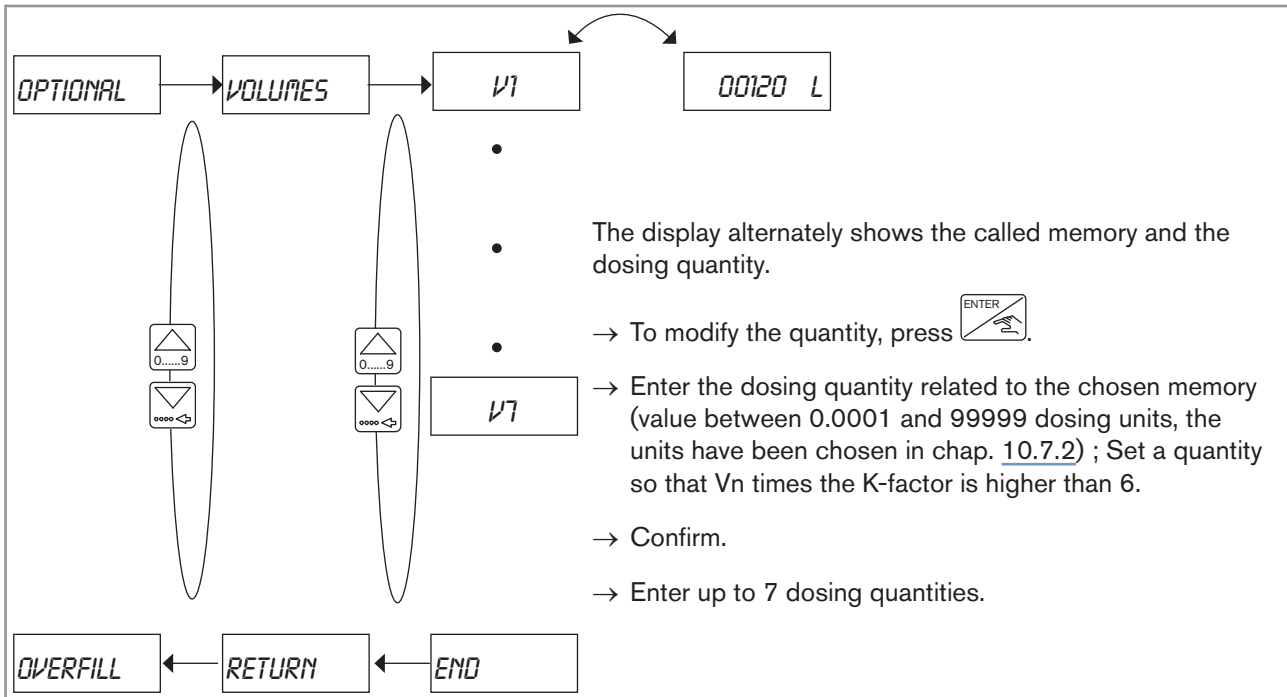

Fig. 74 : Configuring the dosing quantities

10.7.15 Configuring the overfill correction or deactivating it

When a dosing is finished, the device controls the closing of the main valve (or of the auxiliary valve).

The overfilling is the quantity of liquid that has been counted by the device once the valve is closed.

When the overfill correction is active, the overfilling of a dosing is deducted from the next dosing(s).

The overfill correction can be either:

- direct: the overfilling is deducted from the next dosing.
- or smoothed: the device smoothes (with a "low", "medium" or "high" effect) the overfillings of the last x dosings and deducts the calculated value from the next dosing.

Tolerance of the overfilling:

A tolerance for the overfilling value can be furthermore entered: if the overfilling of a dosing exceeds the tolerance, that overfilling value will not be taken into account in the next smoothing calculations and the warning message "W. OVER." is generated by the device. See chap. 11.3.3 to solve the problem.

To avoid a false dosing after a modification in the process, reset the table of the overfill correction values before restarting the process. See Fig. 75.

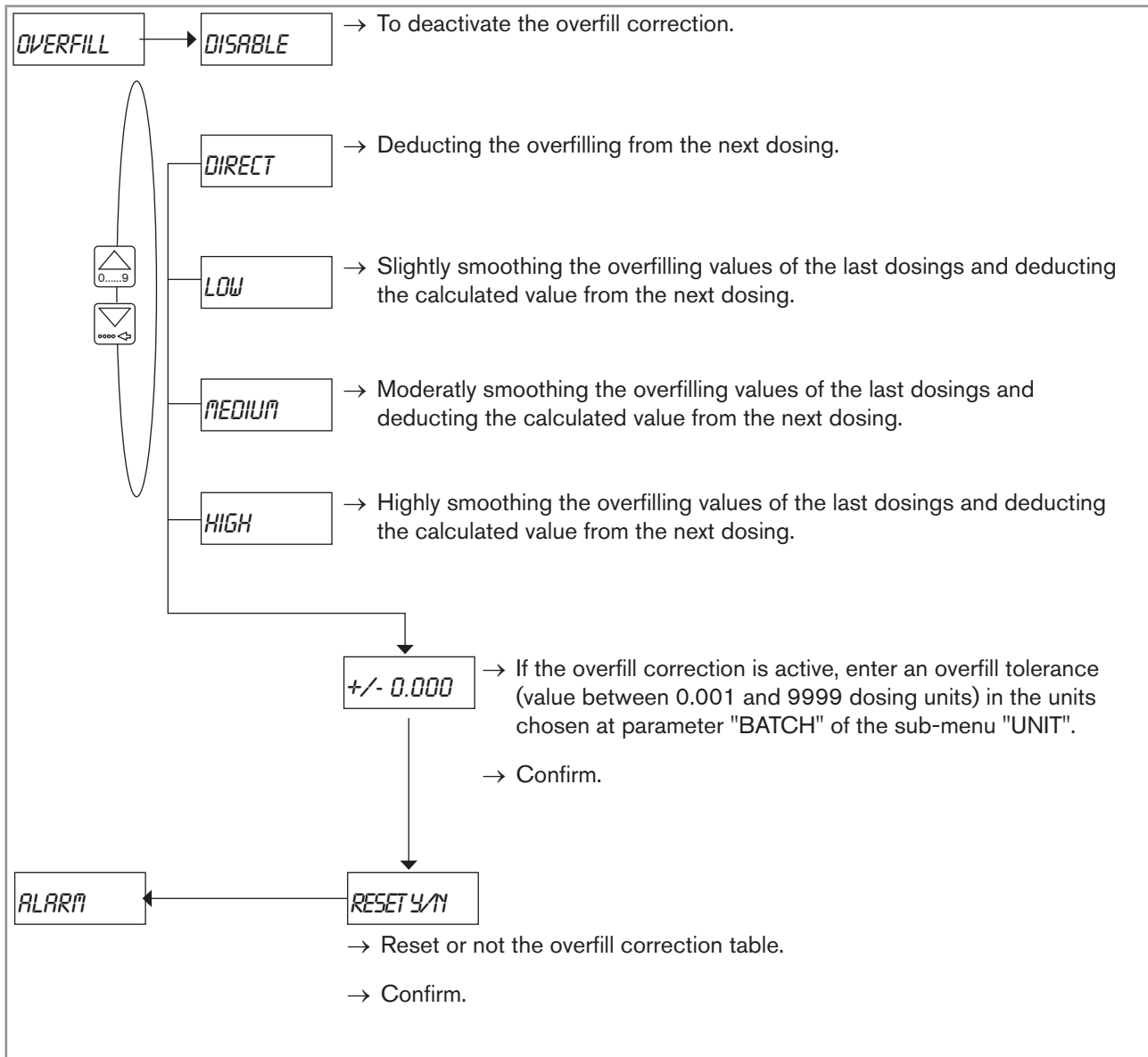

Fig. 75 : Configuring the overfill correction

→ If you do not want to adjust another parameter, go to the "END" parameter of the Parameters menu and press



to save the settings or not and go back to the Process level.

10.7.16 Activating / deactivating the generation of alarms for problems occurring during a dosing

The following problems can occur during a dosing:

- no flow in the pipe whereas the valves are open.
- a flow is measured in the pipe whereas the valves are closed.

These problems can be signalled by the generation of an alarm.

When an alarm is generated, the device stops the process:

- the valves connected to the relay outputs DO2 and DO3 are closed,
- the device state LED becomes orange and flashes fast,
- a 3,5 Hz-frequency is generated on the transistor output DO4 if it is configured to transmit the state of the device (see chap. 10.7.26),
- the outputs configured with the function "ALARM" are switched (see chap. 10.7.19),
- the message "ALARM" is displayed.

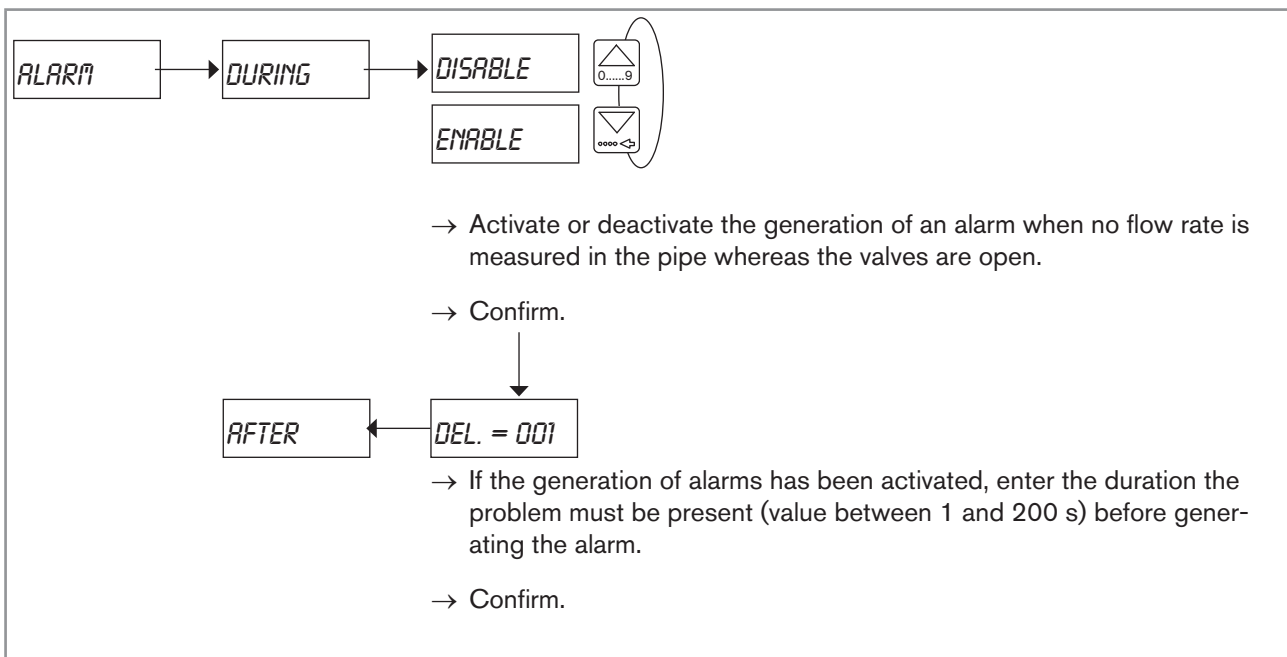

Fig. 76 : Activating / deactivating the generation of alarms for problems occurring during a dosing

→ If you do not want to adjust another parameter, go to the "END" parameter of the Parameters menu and press to save the settings or not and go back to the Process level.

MAN 1000199281 EN Version: C Status: RL (released | freigegeben) printed: 22.09.2017

10.7.17 Activating / deactivating the generation of alarms for problems occurring at the end of a dosing

When the following 3 criteria are fulfilled the dosing is finished:

- no flow rate measured in the pipe,
- the valves are closed,
- and the quantity has entirely been dosed.

If a flow rate is measured in the pipe whereas the valves should be closed (once the dosing is finished or when a dosing has been interrupted), an alarm can be generated.

When an alarm is generated, the device stops the process:

- the valves connected to the relay outputs DO2 and DO3 are closed,
- the device state LED becomes orange and flashes fast,
- a 3,5 Hz-frequency is generated on the transistor output DO4 if it is configured to transmit the state of the device (see chap. [10.7.26](#)),
- the outputs configured with the function "ALARM" are switched (see chap. [10.7.19](#)),
- the message "ALARM" is displayed.

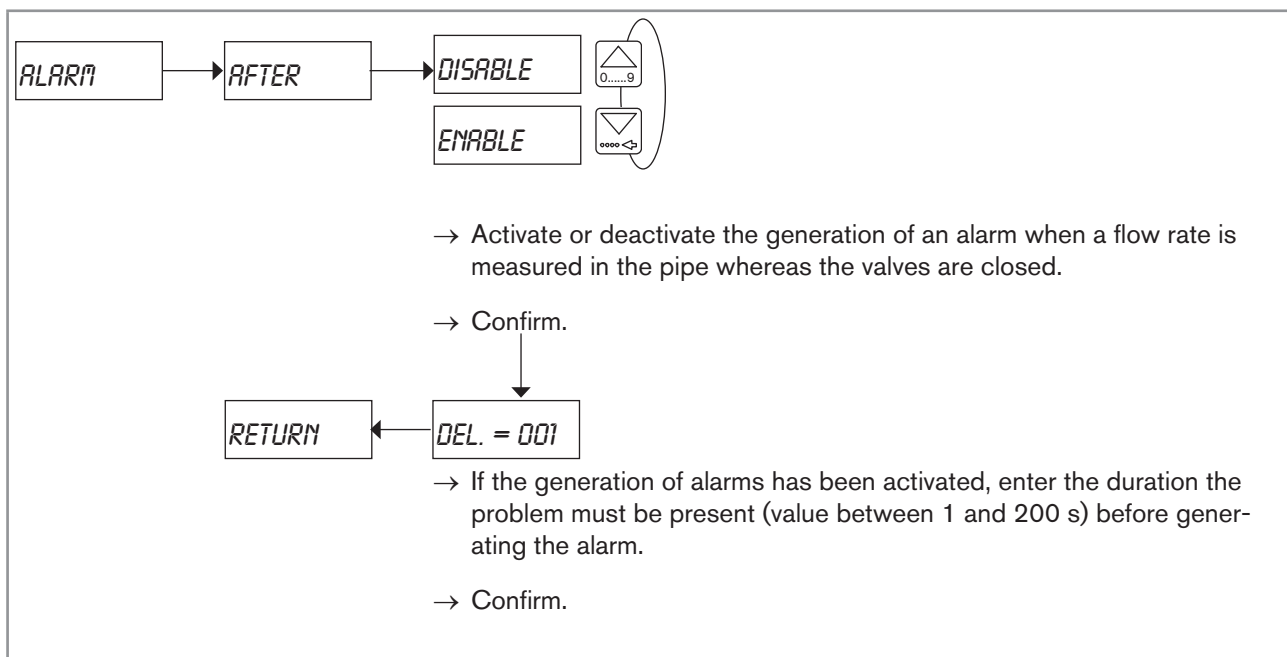



Fig. 77 : Activating / deactivating the generation of alarms for problems occurring at the end of a dosing

→ If you do not want to adjust another parameter, go to the "END" parameter of the Parameters menu and press  to save the settings or not and go back to the Process level.

10.7.18 Configuring the outputs (general diagram)

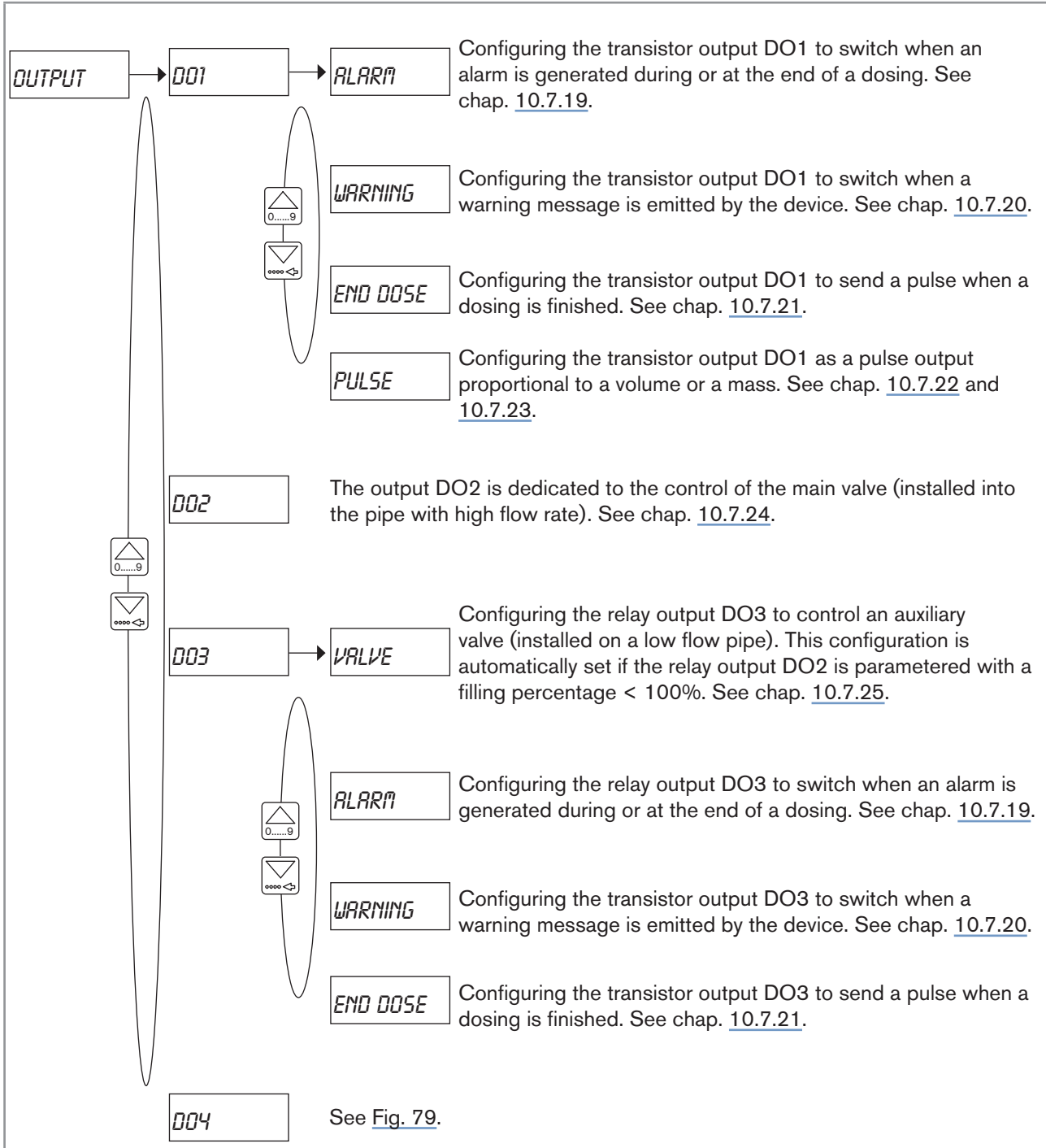

Fig. 78 : Diagram 1/2 of the "OUTPUT" parameter of the Parameters menu

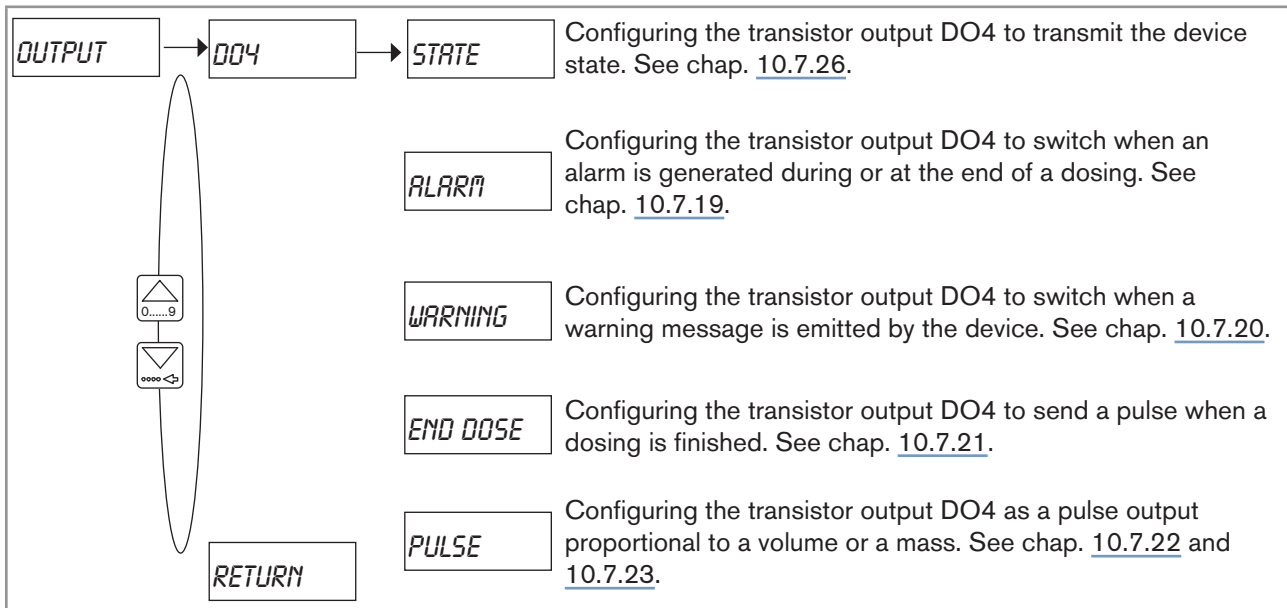



Fig. 79 : Diagram 2/2 of the "OUTPUT" parameter of the Parameters menu

10.7.19 Configuring the transistor output DO1 or DO4 or the relay output DO3 to switch when an alarm is generated during or at the end of a dosing

An alarm is generated during or at the end of a dosing (can be parametered, see chap. [10.7.16](#) et [10.7.17](#)).

The generation of an alarm can be signalled by the switching of the output DO1 and/or DO3 and/or DO4.

 The relay output DO3 can be configured to switch when an alarm is generated during or at the end of a dosing, if the output is not configured to control an auxiliary valve. See chap. [10.7.25](#).

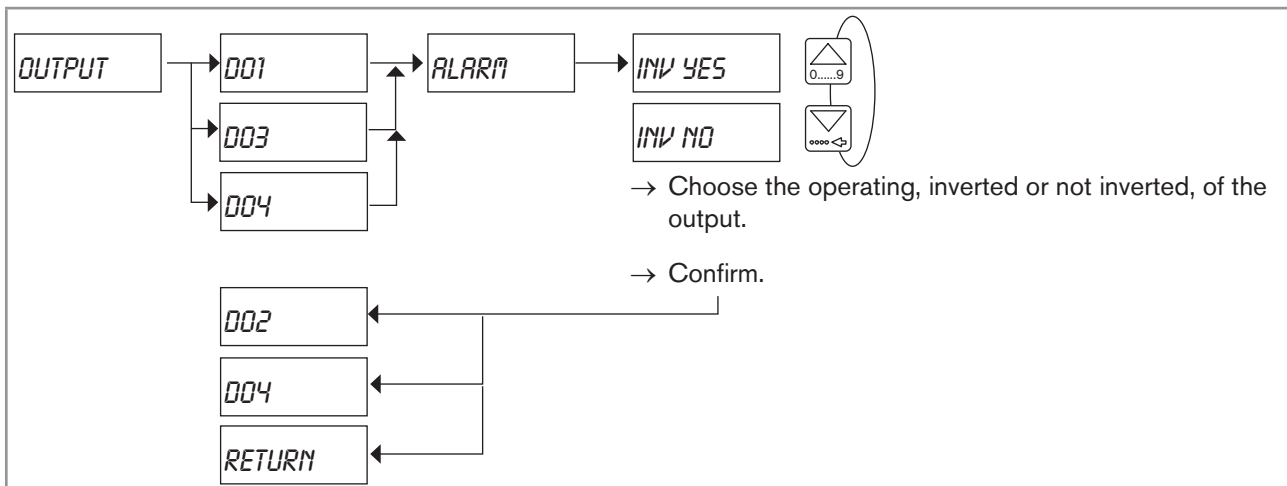

Fig. 80 : Configuring the output DO1 or DO3 or DO4 to signal the generation of an alarm during or at the end of a dosing

→ If you do not want to adjust another parameter, go to the "END" parameter of the Parameters menu and press



to save the settings or not and go back to the Process level.

10.7.20 Configuring the transistor output DO1 or DO4 or the relay output DO3 to switch when a warning message is emitted by the device

When the device generates a warning message, the device state LED is orange.

The generation of a warning message can be indicated by the switching of the output DO1 and/or DO3 and/or DO4.



The relay output DO3 can be configured to switch when a warning message is generated by the device, if the output is not configured to control an auxiliary valve. See chap. [10.7.25](#).

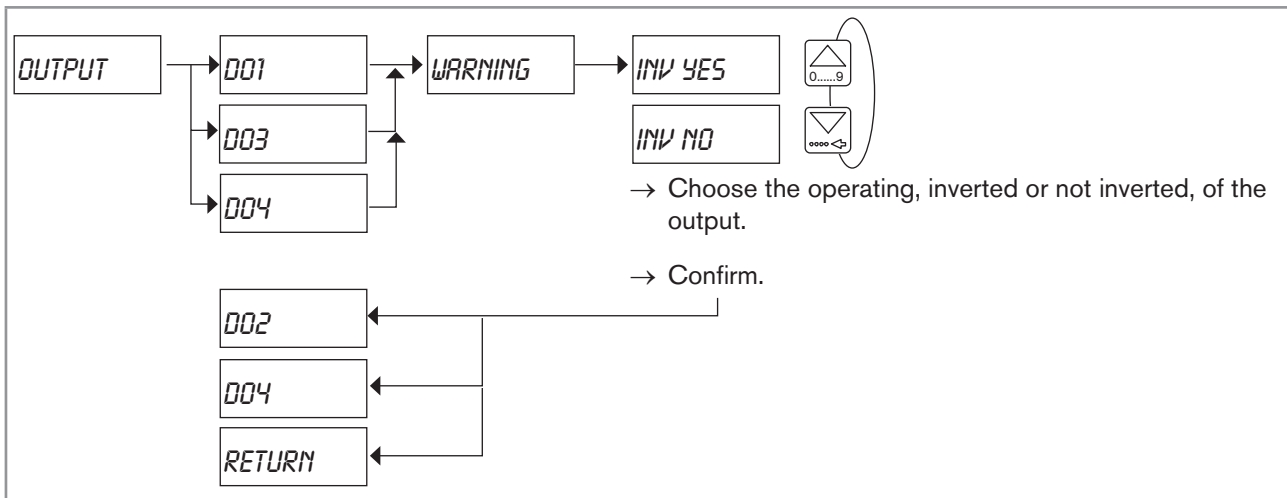

Fig. 81 : Configuring the output DO1 or DO3 or DO4 to indicate the generation of a warning message

→ If you do not want to adjust another parameter, go to the "END" parameter of the Parameters menu and press



to save the settings or not and go back to the Process level.

10.7.21 Configuring the transistor output DO1 or DO4 or the relay output DO3 to signal the end of the dosing

When the 3 following criteria are fulfilled the dosing is finished:

- the valves are closed (with the exception of a dosing being interrupted),
- no flow rate measured in the pipe,
- and the quantity has entirely been dosed.

The end of a dosing can be signalled by the generation of a 200 ms pulse on the output DO1 and/or DO3 and/or DO4, if the dosing has not been aborted on purpose or interrupted by the generation of an "ERROR [T]" alarm.



The relay output DO3 can be configured to signal the end of the dosing, if the output is not configured to control an auxiliary valve. See chap. [10.7.25](#).

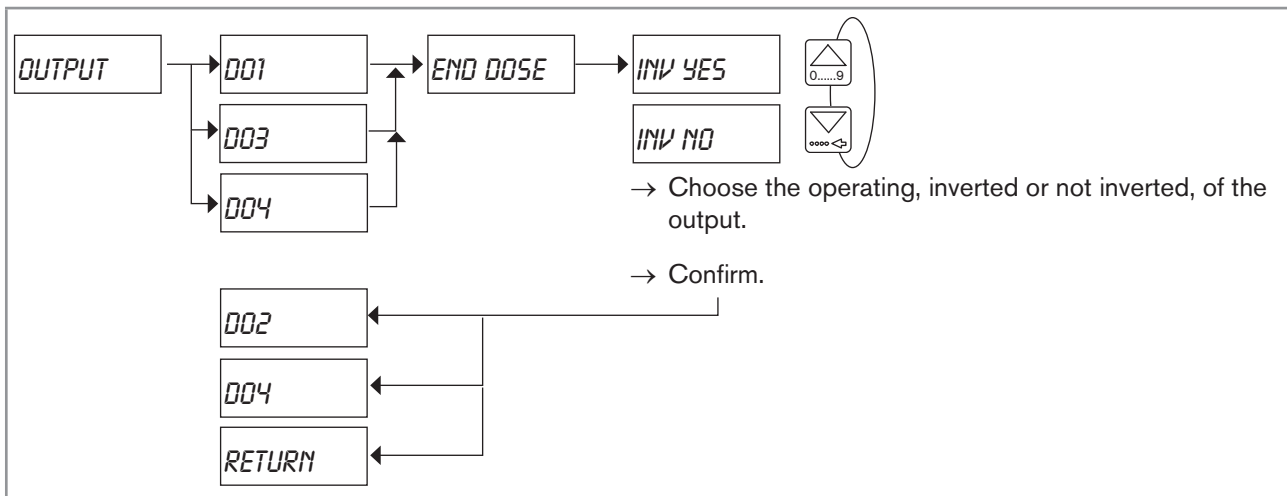



Fig. 82 : Configuring the output DO1 or DO3 or DO4 to signal the end of the dosing

→ If you do not want to adjust another parameter, go to the "END" parameter of the Parameters menu and press  to save the settings or not and go back to the Process level.

10.7.22 Configuring the transistor output DO1 or DO4 as a pulse output proportional to a volume or a mass

When the DO1 or DO4 transistor output is configured as a pulse output proportional to a volume or a mass, a pulse is transmitted on the output each time the parametered volume or mass of fluid has been measured by the device.



- When the frequency emitted on the pulse output is between 0,6 and 300 Hz, the duty cycle of the signal is between 45% and 60%.
- When the frequency emitted on the pulse output is between 300 and 1500 Hz, the duty cycle of the signal is between 40% and 50%.
- When the frequency emitted on the pulse output is between 1500 and 2200 Hz, detection on a pulse edge is possible.

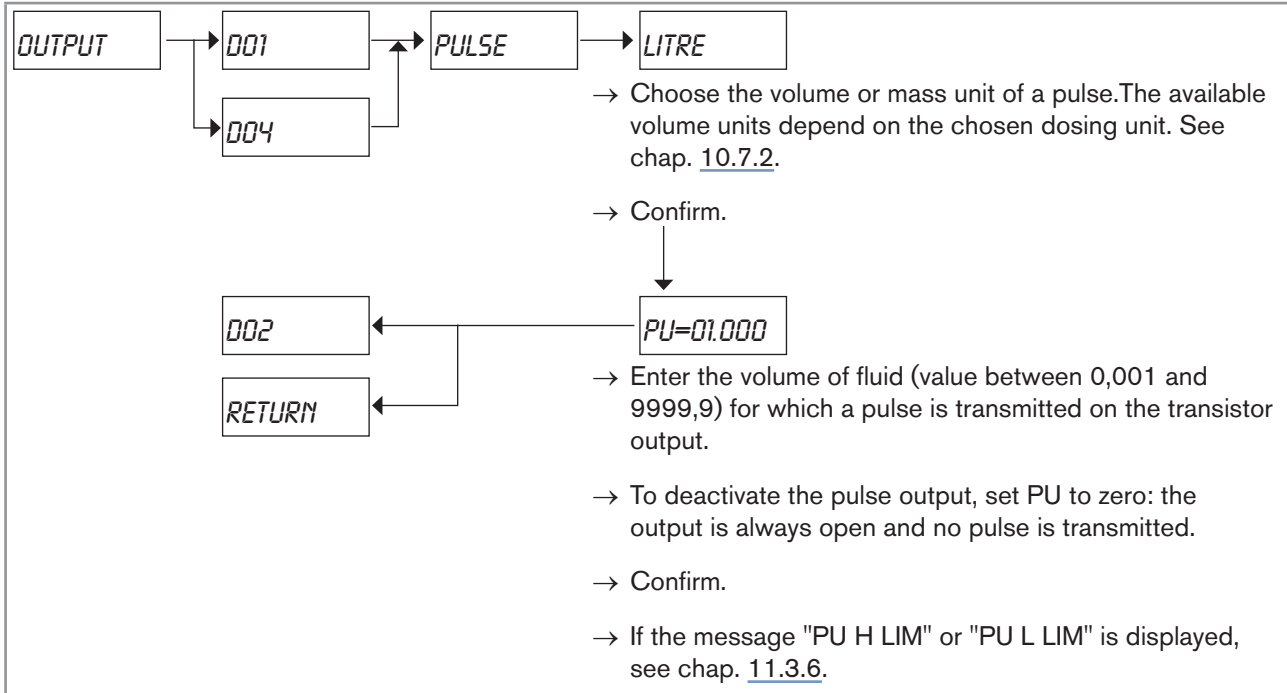

Fig. 83 : Configuring the transistor output DO1 or DO4 as a pulse output proportional to a volume or a mass

→ If you do not want to adjust another parameter, go to the "END" parameter of the Parameters menu and press to save the settings or not and go back to the Process level.

10.7.23 Configuring the transistor output DO1 or DO4 to transmit the rotational frequency of the paddle wheel

When the transistor output DO1 or DO4 is configured with the function "PULSE" and the units "HERTZ", each pulse from the paddle wheel flow sensor is transmitted to the transistor output DO1 or DO4. The frequency generated by this output then equals the rotational frequency of the paddle wheel (this value can be read from the parameter "FREQUENC" in the Test menu).

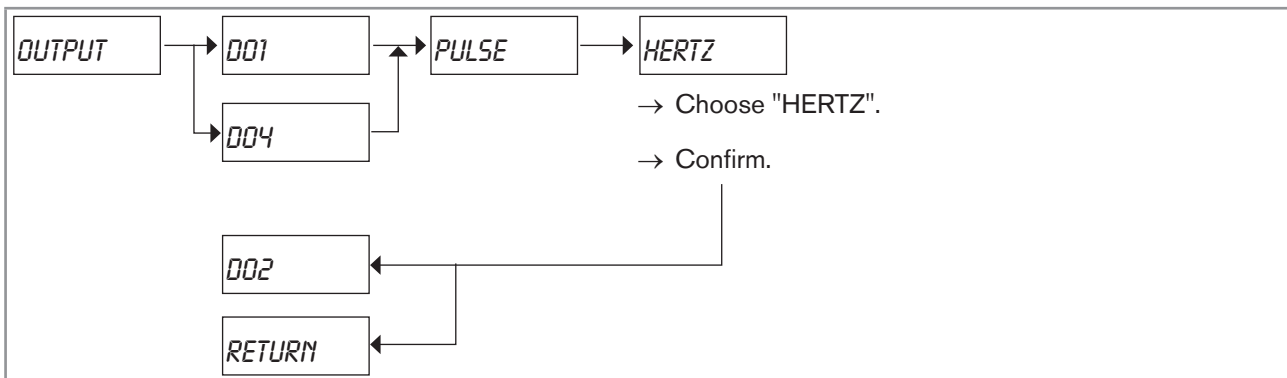

Fig. 84 : Configuring the transistor output DO1 or DO4 as a pulse output proportional to the rotational frequency of the paddle wheel

→ If you do not want to adjust another parameter, go to the "END" parameter of the Parameters menu and press to save the settings or not and go back to the Process level.

10.7.24 Configuring the relay output DO2

! Connect the main valve (installed into the pipe with high flow rate) to the relay output DO2. See chap. 8.14.

The output DO2 is dedicated to the control of the main valve (installed into the pipe with high flow rate).

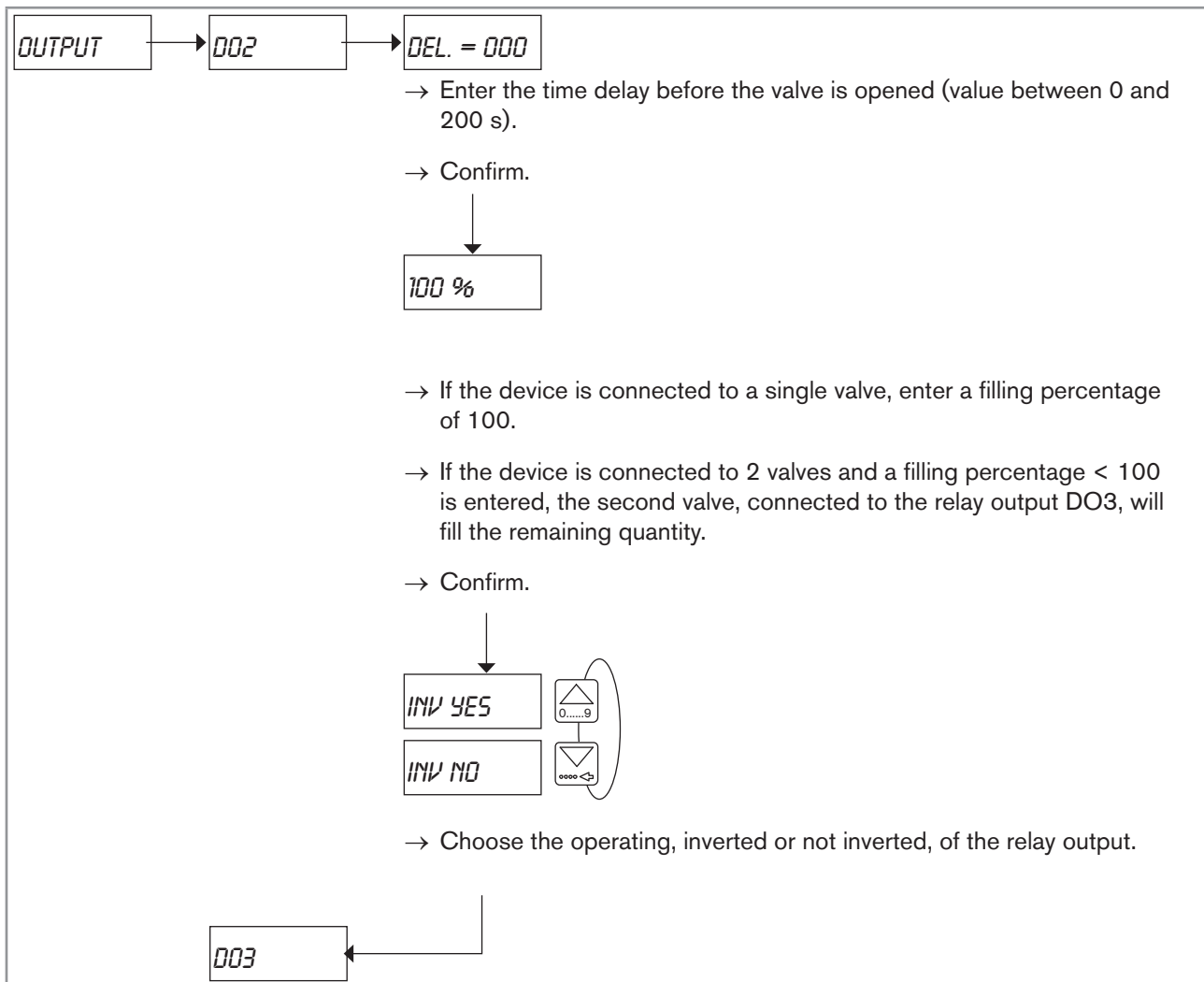

Fig. 85 : Configuring the DO2 relay output

→ If you do not want to adjust another parameter, go to the "END" parameter of the Parameters menu and press



to save the settings or not and go back to the Process level.

10.7.25 Configuring the relay output DO3 to control an auxiliary valve

- Connect the auxiliary valve (installed into the pipe with low flow rate) to the relay output DO3. See chap. [8.14](#).
- The time delay before opening the auxiliary valve is the same as the time delay before opening the main valve.
- If no auxiliary valve is necessary, enter a filling rate of 100 in the settings of the relay output DO2.

If the filling rate associated to the relay output DO2 is < 100, the relay output DO3 is automatically configured to control the auxiliary valve that completes the filling up to 100.

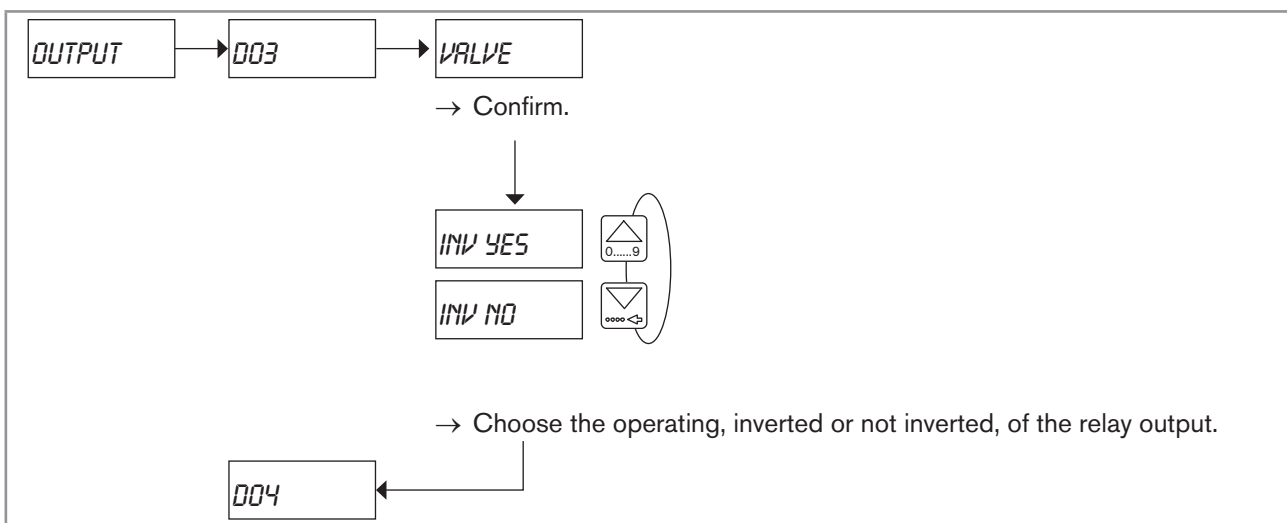

Fig. 86 : Configuring the relay output DO3 to control an auxiliary valve

→ If you do not want to adjust another parameter, go to the "END" parameter of the Parameters menu and press to save the settings or not and go back to the Process level.

10.7.26 Configuring the transistor output DO4 to transmit the device state and activating / deactivating the generation of a 10 Hz frequency when an error message is generated by the device

The transistor output DO4 can be configured to transmit the device state to a LED or a remote instrument (PLC for example).

If, furthermore, the device signals an operating error (see chap. [11.3.2](#)), the transistor output DO4 can be configured to generate a 10 Hz-frequency.

The following states are transmitted:

State of the device	State of the the transistor output DO4
No dosing being done	OFF
Dosing being done	ON
Dosing interrupted	1 Hz-frequency

State of the device	State of the the transistor output DO4
Problem which occurs during or at the end of a dosing: <ul style="list-style-type: none"> ▪ no flow in the pipe whereas the valves are open. ▪ a flow is measured in the pipe whereas the valves are closed. ▪ when the dosing mode "EXT [T]" is active on the device, the activation duration of the digital input DI1 does not respect the conditions described in chap. 10.7.11. 	3,5 Hz-frequency
An error message has been generated by the device. See chap. 11.3	10 Hz-frequency, if the function is active on the device: see Fig. 87
The power supply has been cut during a dosing	10 Hz-frequency for 2 seconds when the device is started, if the function is active on the device: see Fig. 87
Selected quantity Vn, when the dosing mode "EXT. +LOC" is active (see Fig. 47, chap. 10.6.4)	n pulses generated at a 50 Hz-frequency

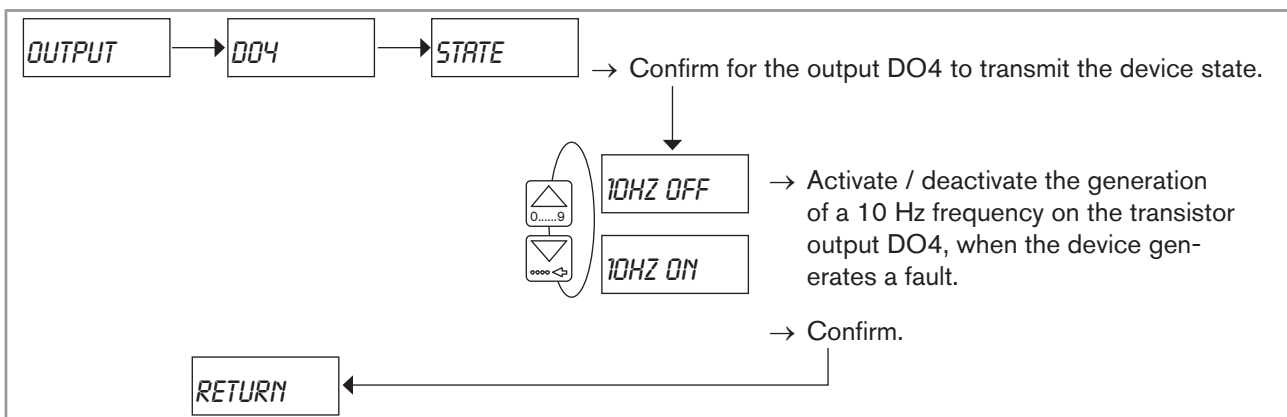



Fig. 87 : Configuring the transistor output DO4 to transmit the device state

→ If you do not want to adjust another parameter, go to the "END" parameter of the Parameters menu and press  to save the settings or not and go back to the Process level.

10.7.27 General diagram of the "RESET" sub-menu

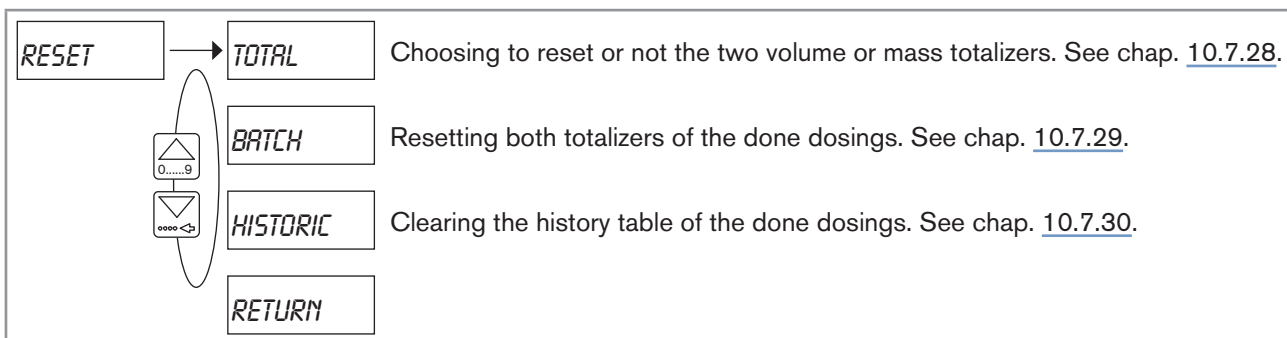

Fig. 88 : General diagram of the "RESET" sub-menu

10.7.28 Resetting the two volume or mass totalizers

The function allows for resetting the two volume or mass totalizers.

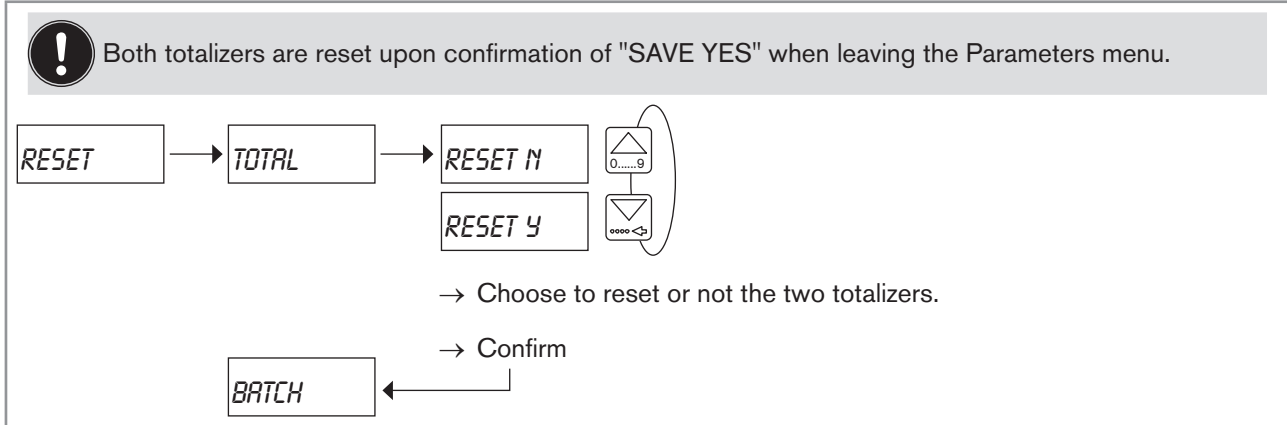

Fig. 89 : Diagram of the "TOTAL" parameter of the sub-menu "RESET"

The daily totalizer can be reset from the Process level. See chap. [10.6](#).

→ If you do not want to adjust another parameter, go to the "END" parameter of the Parameters menu and press to save the settings or not and go back to the Process level.

10.7.29 Resetting the two totalizers of the done dosings

The function allows for resetting the two totalizers of the done dosings.

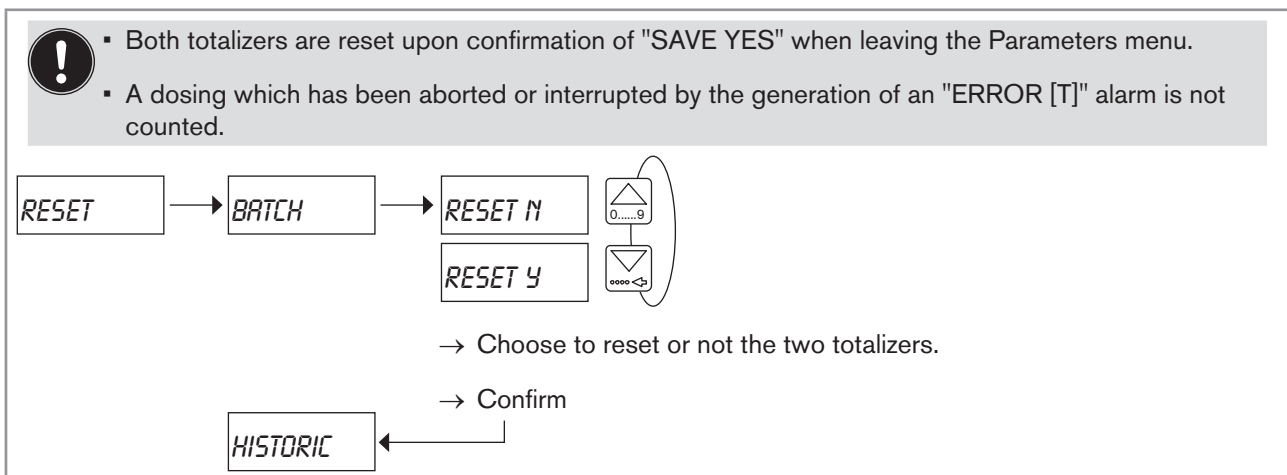

Fig. 90 : Diagram of the "BATCH" parameter of the sub-menu "RESET"

The daily totalizer can be reset from the Process level. See chap. [10.6](#).

→ If you do not want to adjust another parameter, go to the "END" parameter of the Parameters menu and press to save the settings or not and go back to the Process level.

10.7.30 Clearing the history table of the done dosings

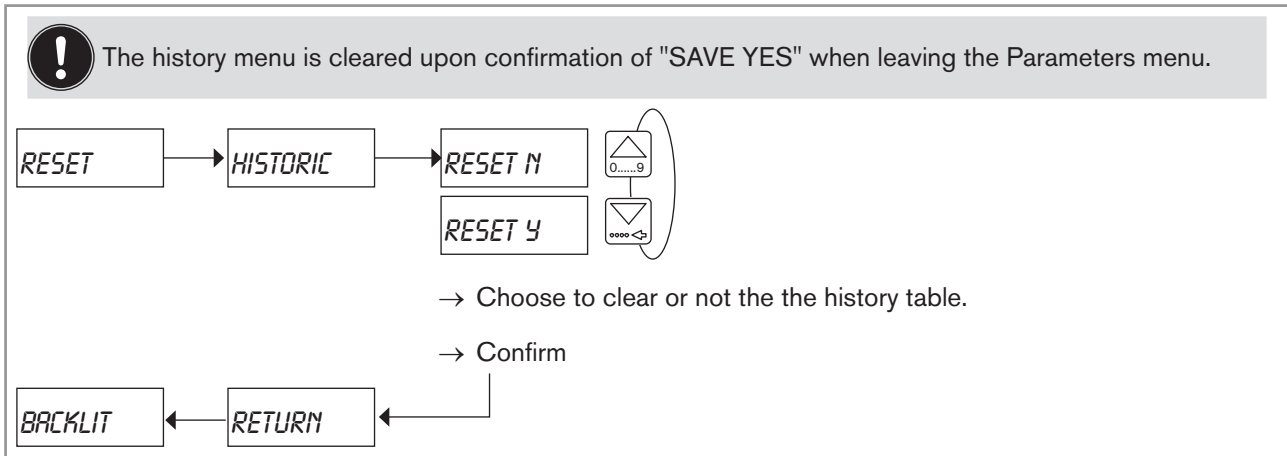

Fig. 91 : Diagram of the "HISTORIC" parameter of the sub-menu "RESET"

→ If you do not want to adjust another parameter, go to the "END" parameter of the Parameters menu and press to save the settings or not and go back to the Process level.

10.7.31 Setting the brightness of the display and how long it stays ON, or deactivating the backlight

This parameter makes it possible:

- to adjust the brightness of the display and how long the display is backlit after a key press.
- to deactivate the backlight.

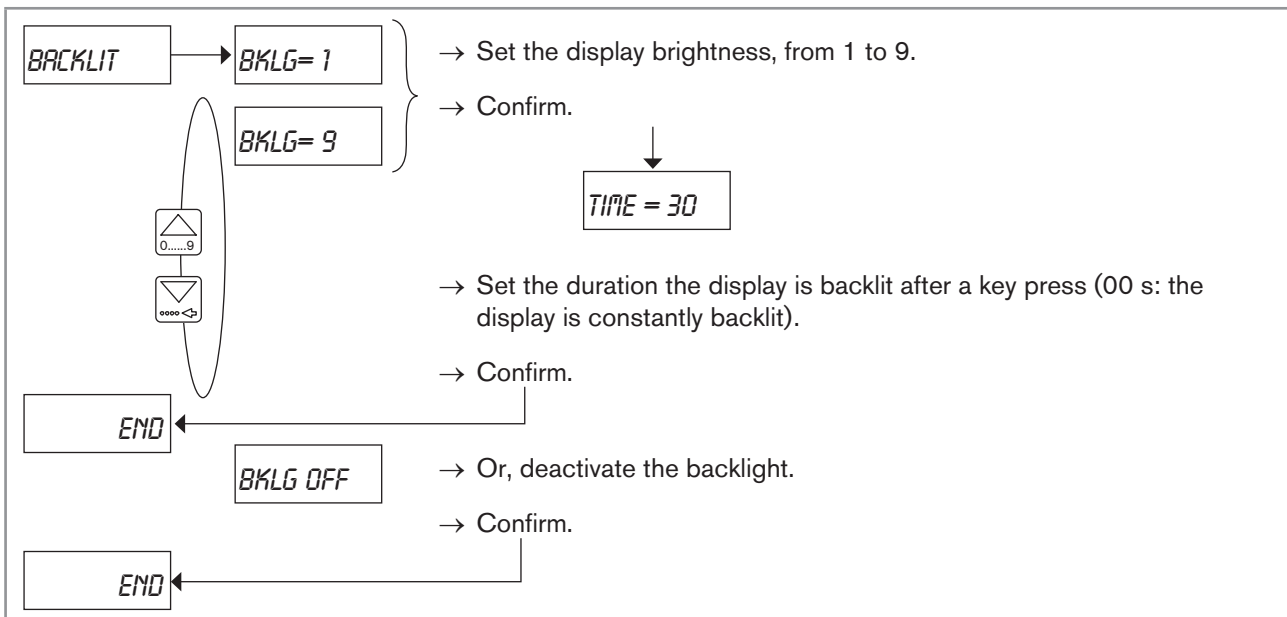

Fig. 92 : Diagram of the "BACKLIT" parameter of the Parameters menu

→ If you do not want to adjust another parameter, confirm the "END" parameter to save the settings or not and go back to the Process level.

10.8 Details of the Test menu

To access the Test menu, simultaneously press keys for at least 5 s.

This menu comprises the following configurable parameters:

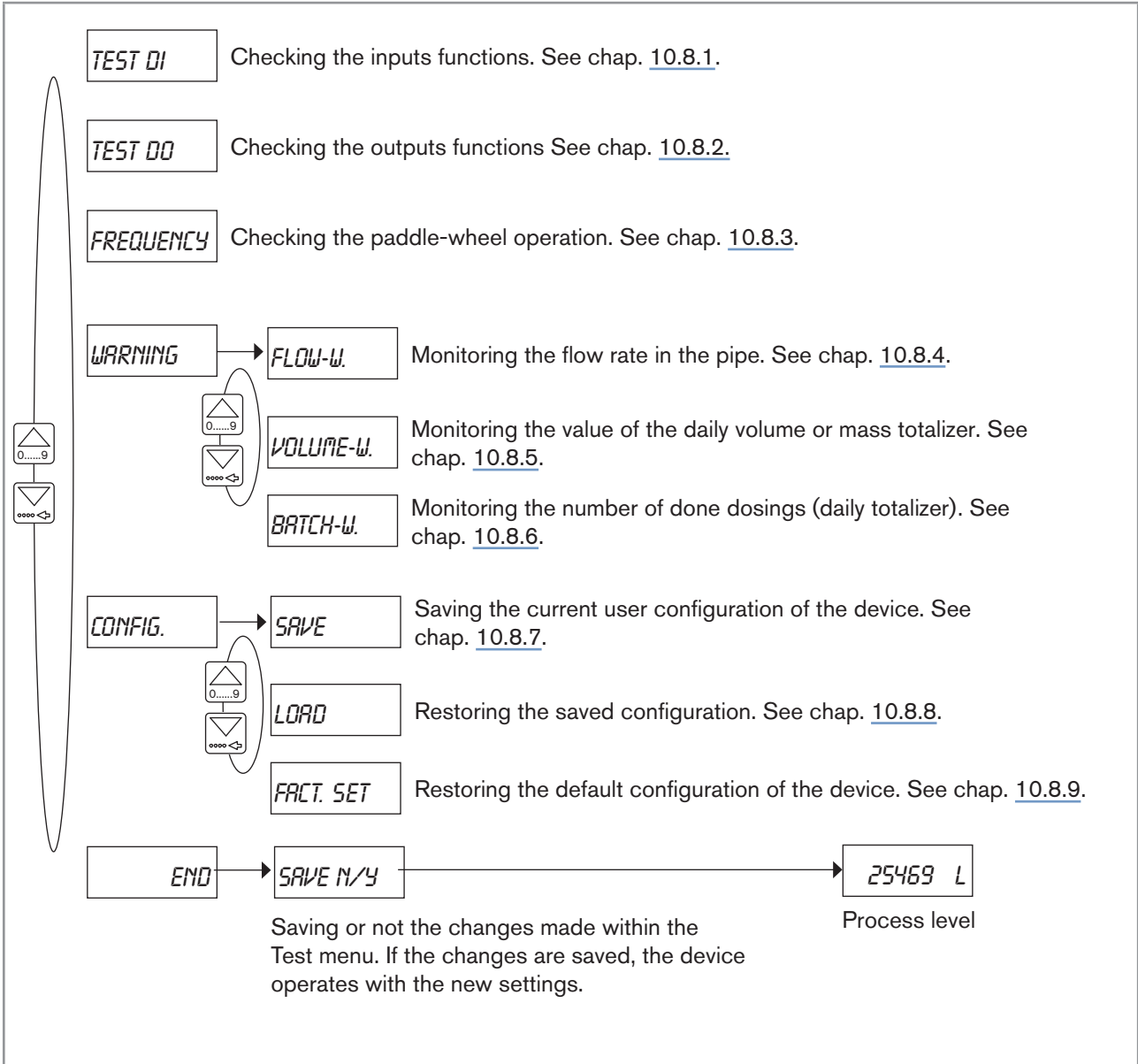

Fig. 93 : Diagram of the Test menu

10.8.1 Checking the inputs functions

The function allows for checking the correct working of the digital inputs.

! The device state LED flashes during the running check of the input working.

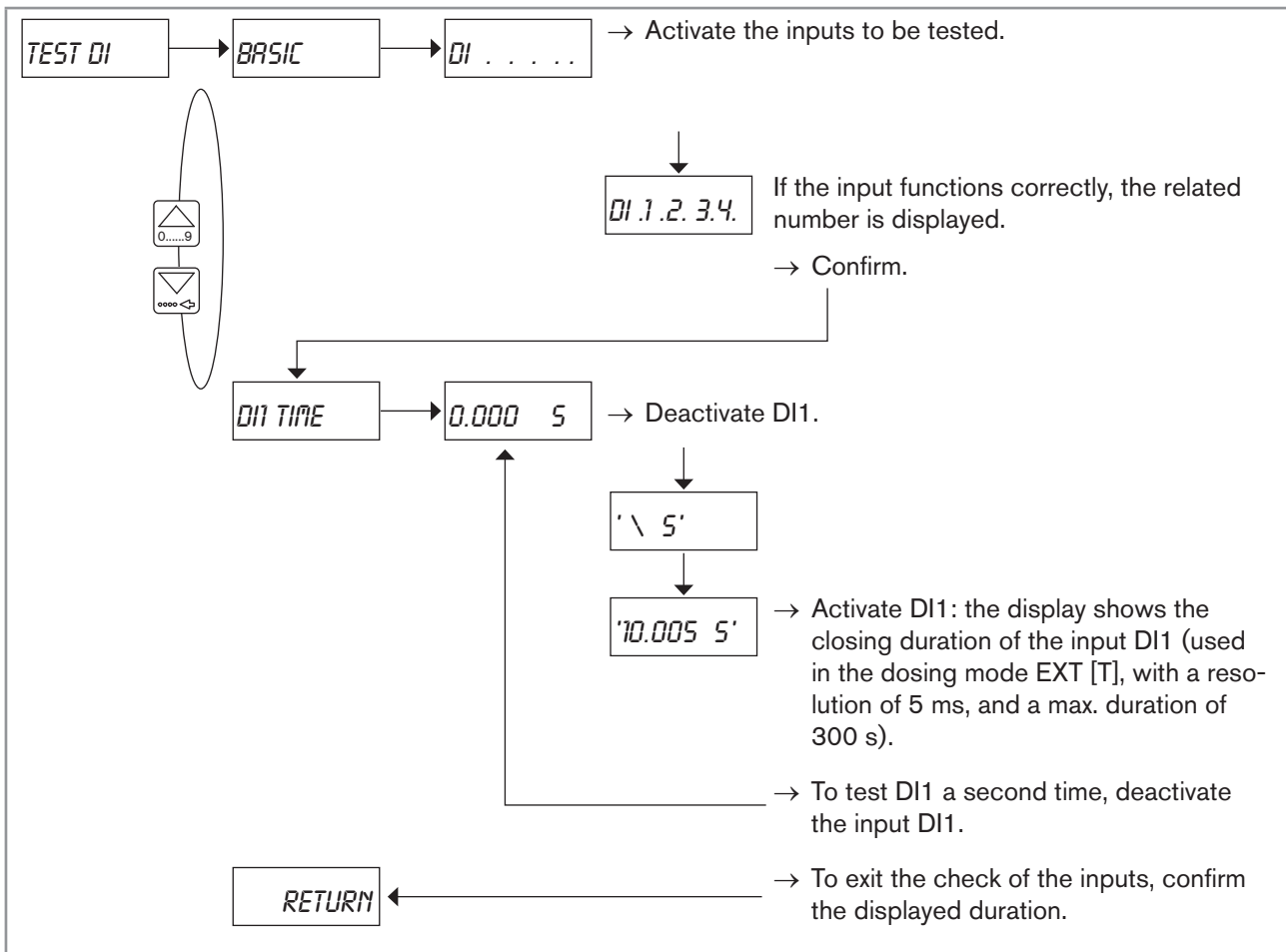



Fig. 94 : Diagram of the "TEST DI" parameter of the Test menu

→ If you do not want to adjust another parameter, go to the "END" parameter of the Test menu and press  to save the settings or not and go back to the Process level.

10.8.2 Checking the outputs functions

! If a valve is connected to the output DO2 or DO3, this function will open the valve.

The function allows for checking the correct working of the outputs.

- !** The device state LED flashes during the running check of the output working.
- After having confirmed the output to be checked, the display shows the current state of the output ("DOx ON" or "DOx OFF").

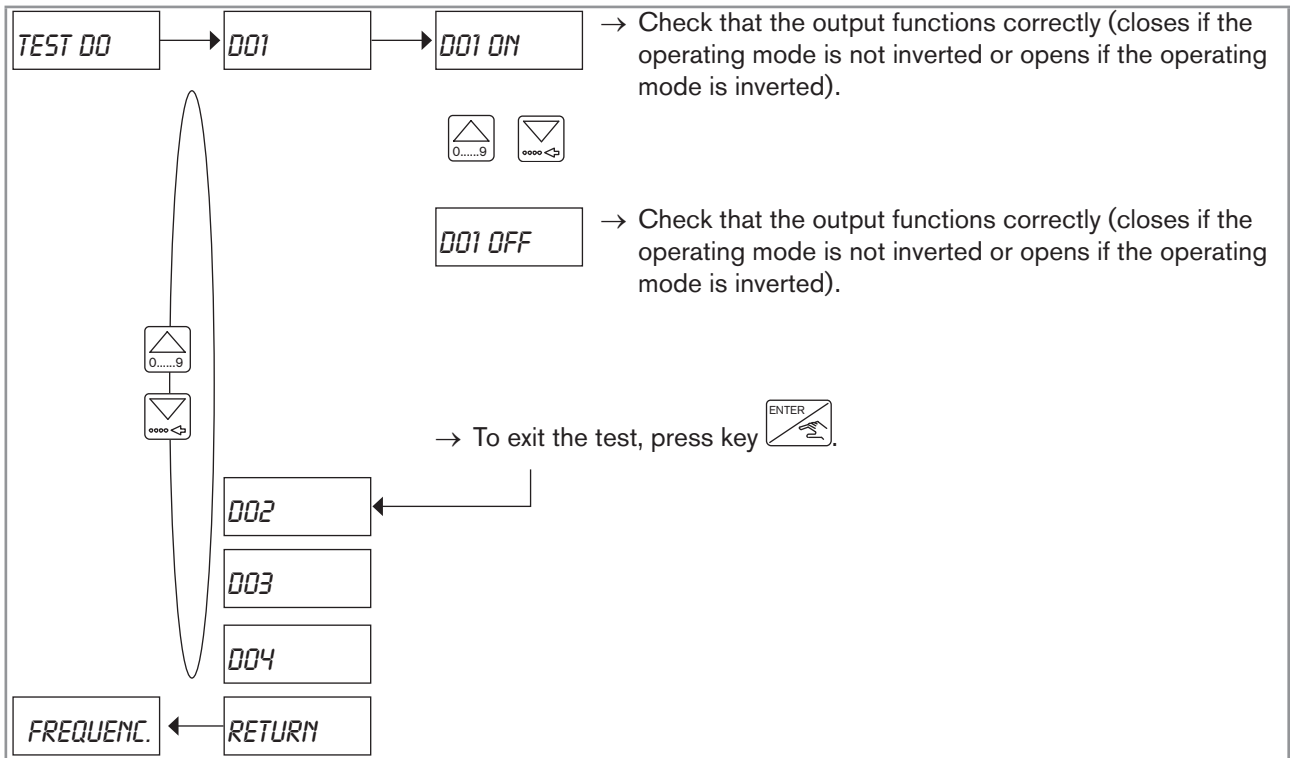

Fig. 95 : Diagram of the "TEST DO" parameter of the Test menu

→ If you do not want to adjust another parameter, go to the "END" parameter of the Test menu and press to save the settings or not and go back to the Process level.

10.8.3 Checking the paddle-wheel operation

! Risk of disrupting the process due to accidental opening of the valves.

- Before confirming the parameter "FREQUENC" and thus opening the valves, make sure there is no risk for the process.

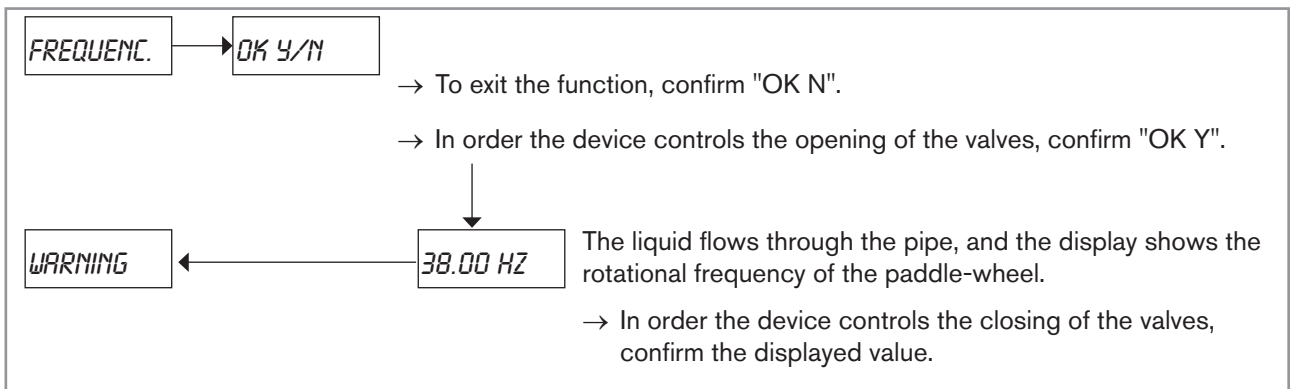

Fig. 96 : Diagram of the "FREQUENC." parameter of the Test menu

→ If you do not want to adjust another parameter, go to the "END" parameter of the Test menu and press to save the settings or not and go back to the Process level.



MAN 1000199281 EN Version: C Status: RL (released | freigegeben) printed: 22.09.2017

10.8.4 Monitoring the flow rate in the pipe

A malfunction in your process or in the flow sensor may be indicated either by too low or too high a flow rate.

The parameter "FLOW-W." makes it possible to monitor the flow rate.



- To disable the flow rate monitoring, set $W^- = W^+ = 0$.
- To disable one of the limits, set it to 0.
- When the warning message "WARN. LO" or "WARN. HI" is generated, access to the information menu, go to the message and confirm the message by simultaneously pressing the keys  and  for 2 seconds.

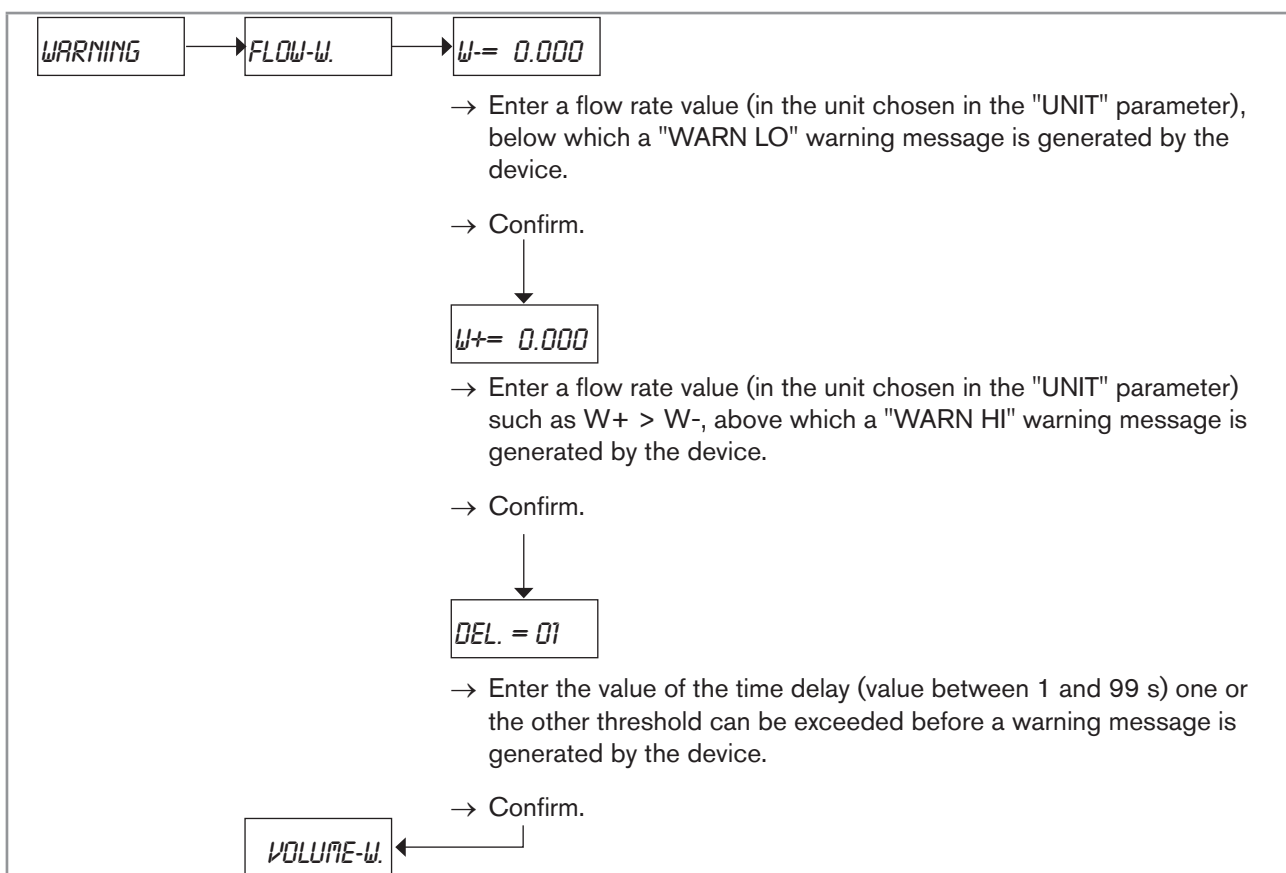

Fig. 97 : Diagram of the "FLOW-W." parameter of the sub-menu "WARNING"

To be warned when the flow rate is too low or too high, enter the flow rate range (in the units that have been chosen in the "UNIT" parameter of the Parameters menu), outside which the device generates a warning message, "WARN LO" or "WARN HI", and turns the device status LED to orange.

When a warning message, "WARN LO" or "WARN HI", is generated by the device:

- check the process.
- if the process is not faulty, check the flow sensor condition and clean it if necessary.
- if the flow rate measurement is still faulty, contact the Bürkert retailer.



- The transistor output DO1 or DO4 or the relay output DO3 can be configured to switch when a warning message is emitted by the device. See chap. [10.7.18](#).
- See also "If you encounter problems" in chap. [11.3](#)

→ If you do not want to adjust another parameter, confirm the "END" parameter to save the settings or not and go back to the Process level.

10.8.5 Monitoring the value of the daily volume or mass totalizer

The parameter "VOLUME-W." makes it possible to monitor the value of the volume or mass daily totalizer. When the daily totalizer has reached the set value, a warning message is generated by the device.



- To deactivate the monitoring of the totalizer, set "VOLUME-W." to zero.
- When the warning message "WARN. VOL." is sent out, reset the daily volume or mass totalizer: see chap. [10.6](#) or [10.7.28](#).

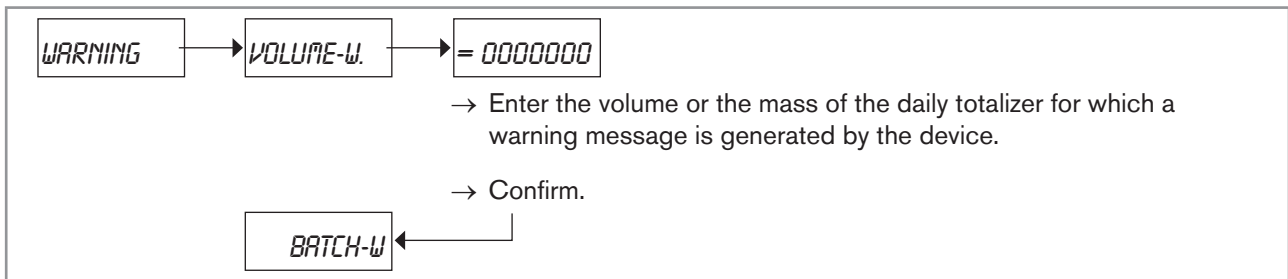

Fig. 98 : Diagram of the "VOLUME-W." parameter of the sub-menu "WARNING"



- The transistor output DO1 or DO4 or the relay output DO3 can be configured to switch when a warning message is emitted by the device. See chap. [10.7.18](#).
- See also "If you encounter problems" in chap. [11.3](#)

→ If you do not want to adjust another parameter, confirm the "END" parameter to save the settings or not and go back to the Process level.

10.8.6 Monitoring the number of done dosings

The parameter "BATCH-W." makes it possible to monitor the value of the done dosings daily totalizer. When the daily totalizer has reached the set value, a warning message is generated by the device.



- To deactivate the monitoring of the number of done dosings, set "BATCH-W." to zero.
- When the warning message "W. BATCH" is sent out, reset the daily totalizer of the done dosings: see chap. [10.6](#) or [10.7.28](#).

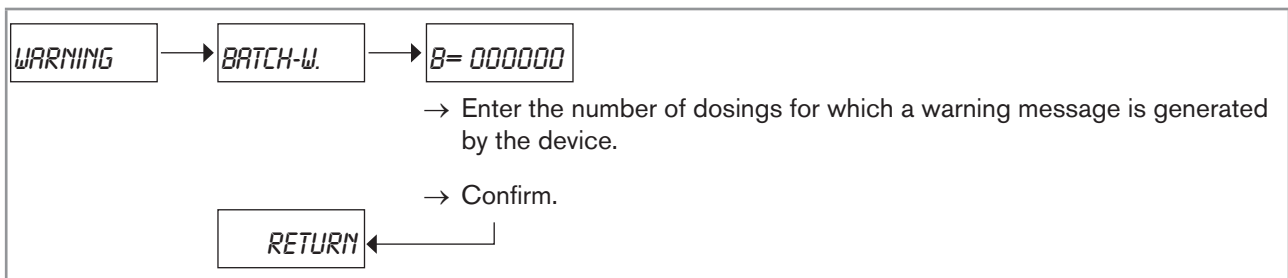

Fig. 99 : Diagram of the "BATCH-W." parameter of the sub-menu "WARNING"



- The transistor output DO1 or DO4 or the relay output DO3 can be configured to switch when a warning message is emitted by the device. See chap. [10.7.18](#).
- See also "If you encounter problems" in chap. [11.3](#)

→ If you do not want to adjust another parameter, confirm the "END" parameter to save the settings or not and go back to the Process level.

10.8.7 Saving the user set configuration

You may save the current configuration of the device in order to restore it later.

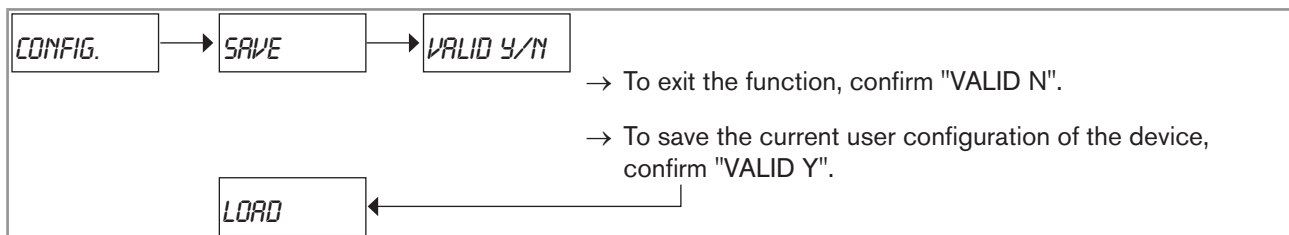

Fig. 100 : Saving the current user configuration

→ If you do not want to adjust another parameter, confirm the "END" parameter to save the settings or not and go back to the Process level.

10.8.8 Restoring the saved configuration

You can restore the configuration of the device that has been previously saved (see chap. [10.8.7](#)).



The device will use the restored configuration as soon as "SAVE YES" is confirmed when leaving the Test menu.

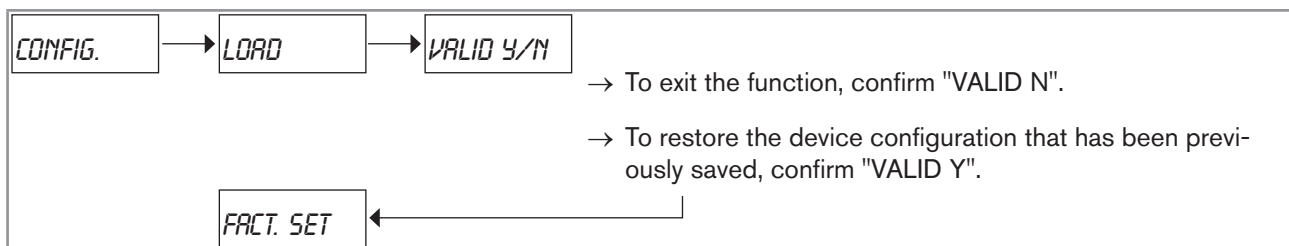

Fig. 101 : Restoring the configuration previously saved

→ If you do not want to adjust another parameter, confirm the "END" parameter to save the settings or not and go back to the Process level.

10.8.9 Restoring the default configuration



The device will use the default configuration as soon as "SAVE YES" is confirmed when leaving the Test menu.

The parameter makes it possible to restore the default configuration of the device ([Tab. 10](#)).

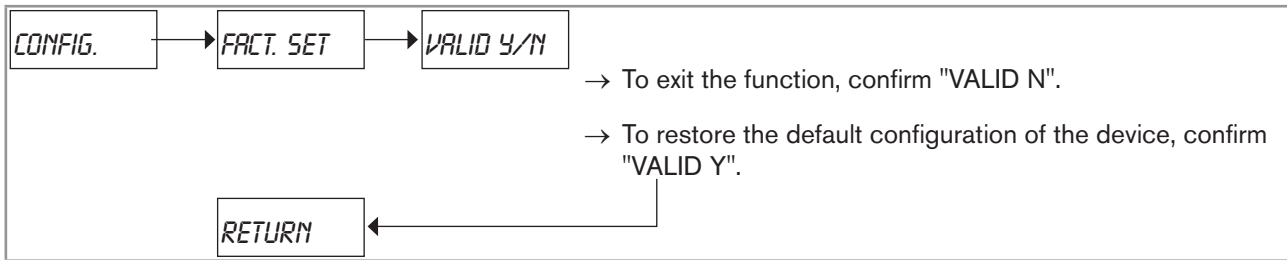

Fig. 102 : Restoring the default configuration of the device

Tab. 10 : Default configuration of the device

Function	Default value
LANGUAGE	English
Dosing UNITS	litre
UNIT of the flow rate	l/s
UNIT of the totalizers	litre, 0 decimals
K FACTOR	1.00
OPTIONAL	dosing mode "LOC. MANU"
	V1 to V7=0.00
Parameters A and B for dosing mode "EXT. [T]"	0
Teach-In dosing quantity for dosing modes "EXT. REP." and "LOC. REP."	0
OVERFILL CORRECTION	yes, direct, tolerance 0
ALARME during dosing	no
	Time delay = 1s
ALARME at the end of the dosing	no
	Time delay = 1s
OUTPUT DO1	Pulse, PU=0.0
	Litre
OUTPUT DO2	Valve 100%, not inverted, time delay before opening = 0 s
OUTPUT DO3	Alarm, not inverted
OUTPUT DO4	State
	ERR10Hz inactive
BACKLIGHT	level 9, activated for 30s
FLOW-WARNING	W- = W+ = 0.000
	Time delay = 1s
VOLUME-WARNING	0
BATCH-WARNING	0

→ If you do not want to adjust another parameter, confirm the "END" parameter to save the settings or not and go back to the Process level.

10.9 Details of the History menu

To access the History menu, press the  key for at least 2 s, in the Process level.

The menu makes it possible to consult the quantities dosed in the last 10 dosings done on the device.

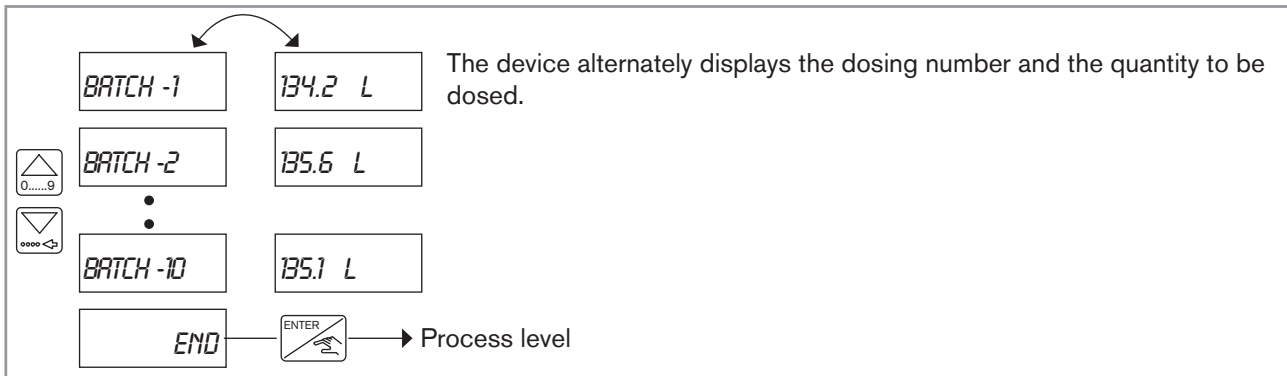



Fig. 103 : Diagram of the History menu

10.10 Details of the Information menu

- ! This menu is available when the device state LED is orange or red.
- For the meaning of a message, go to chap. [11.3](#).
- The messages "WARN. LOW", "WARN. HIG" and "W. OVER." can be confirmed in the Information menu by simultaneously pressing keys  and  for 2 seconds: the message "OK" is displayed.
- The messages "WARN. VOL" and "W. BATCH" are confirmed when the related totalizers are reset.

To access the Information menu, press the  key for at least 2 s, in the Process level.

In this menu read the fault and warning messages generated by the device.

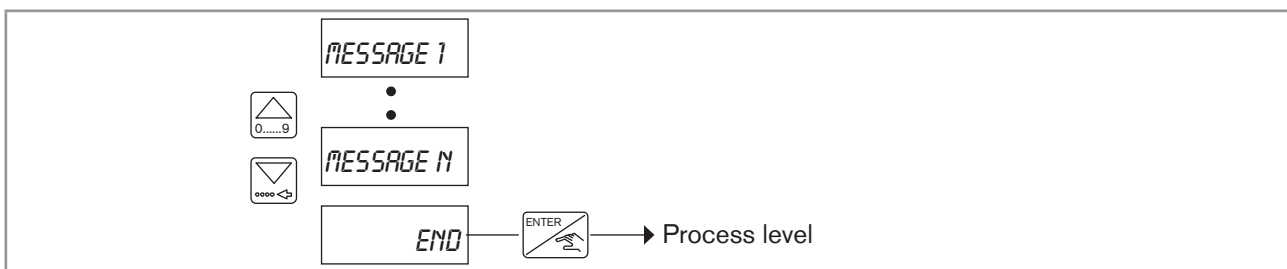

Fig. 104 : Diagram of the Information menu

→ To remotely consult and confirm the warning messages, see chap. [10.11](#).

10.11 Remote consultation and confirmation of the warning messages

! If the power supply of the device is cut during the remote consultation, the device will generate for 2 s a few 10 Hz-pulses on the output DO4 configured with the function "STATE" and the Process level will be active when the power supply is restored.

- !** When the remote consultation is active on the device:
- no dosing can be done.
 - the digital inputs are only used for the consultation and the confirmation of the warning messages.
 - the navigation keys are blocked, except to exit the consultation when "END" is displayed.
 - the device state LED flashes.

Remote consultation and confirmation of the warning messages via the digital inputs is only possible:

- from the Process level,
- when no dosing is being done on the device.
- if at least 1 warning message has been generated (the output(s) configured with the function "WARNING" take the value 1).

To use the feature:

- Configure the device with the dosing mode "EXT. MEM", "EXT.+LOC", "EXT. [T]" or "EXT. REP".
- Connect the 4 digital inputs DI1 to DI4 to 4 outputs of the PLC.
- Configure DO1 or DO3 with the function "WARNING": see chap. 10.7.20.
- Connect the transistor output DO1 or the relay output DO3 to an input of the PLC.
- In order for the PLC to be informed that the remote consultation has started or has finished, connect the transistor output DO4 to an input of the PLC and configure the output DO4 with the function "STATE": see chap. 10.7.26.

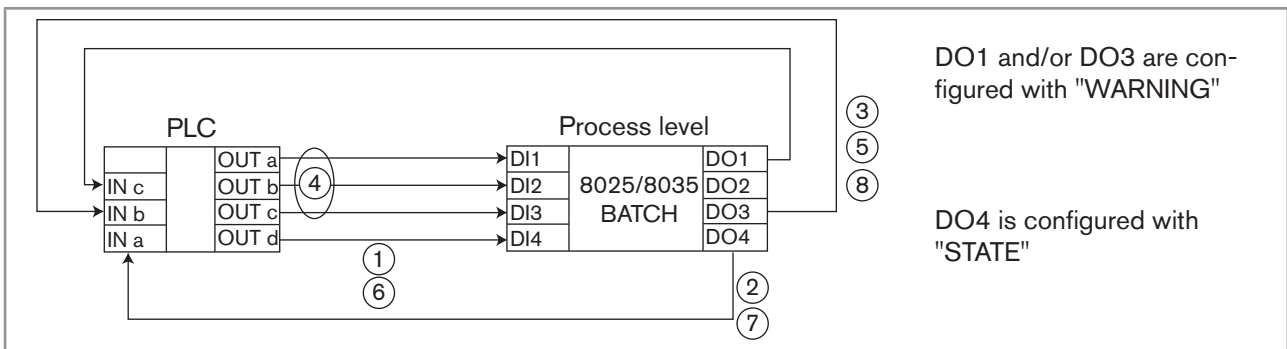

Fig. 105 : Remote consultation of the warning messages

1. To remotely access to the warning messages, the PLC sends out the code 000 on the digital inputs DI1 to DI3 then 1 pulse on DI4.
2. The device generates a 200 ms pulse on the output DO4 to confirm the access to the messages; The dosing feature cannot be accessed any more.
3. The output(s) configured with the function "WARNING" are switched to 0.
4. To identify which warning messages have been generated by the device, the PLC sends one after the other on the digital inputs DI1 to DI3 the codes related to the messages (see [Tab. 11](#)).
5. When the PLC encounters a message that has been generated by the device, the output(s) configured with the function "WARNING" switch to 1.
6. To confirm the message, the PLC sends out one pulse on DI4 and, if the active message is "WARN. VOL." or "W. BATCH", the related daily totalizer is reset.
7. To exit the consultation, the PLC sends the code 000 on the digital inputs DI1 to DI3 then confirms "END" by sending out one pulse on DI4. Pressing the key ENTER also confirms "END".
8. The device generates a 200 ms pulse on the output DO4 to confirm the end of the message consultation; The dosing feature is available again.

Tab. 11 : Code DI1/DI2/DI3 of the warning messages

DI1	DI2	DI3	Chosen message
0	0	0	END
1	0	0	WARN.LOW
0	1	0	WARN.HIG.
1	1	0	WARN. VOL.
0	0	1	W. BATCH
1	0	1	W.OVER

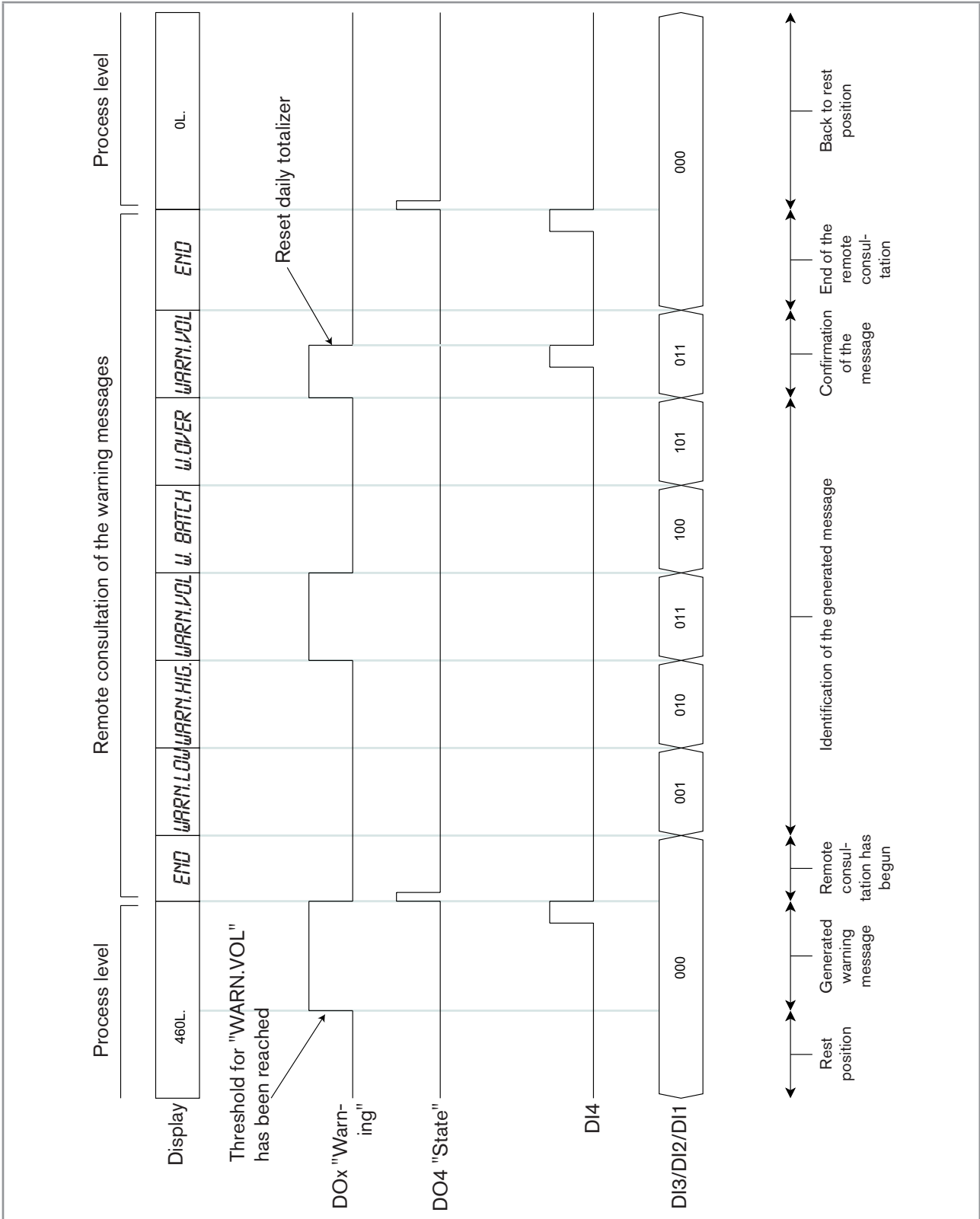

Fig. 106 : Timing chart for the remote consultation of the warning messages

11 MAINTENANCE AND TROUBLESHOOTING

11.1 Safety instructions



DANGER

Danger due to electrical voltage.

- ▶ Disconnect the electrical power for all the conductors and isolate it before carrying out work on the system.
- ▶ Observe all applicable accident protection and safety regulations for electrical equipment.



WARNING

Risk of injury due to non-conforming maintenance.

- ▶ Maintenance must only be carried out by qualified and skilled staff with the appropriate tools.
- ▶ Ensure that the restart of the installation is controlled after any interventions.

11.2 Cleaning the device

The device can be cleaned with a cloth dampened with water or a detergent compatible with the materials the device is made of.

Please feel free to contact your Bürkert supplier for any additional information.

11.3 If you encounter problems

11.3.1 Resolution of problems when the device state LED is OFF

Device state LED	Output DO4	Output DO1 and/or DO2 and/or DO3	Possible cause	Recommended action
OFF	0 Hz	not switched	The device is not energized.	<ul style="list-style-type: none"> → Check the wiring. → Check the fuse of the installation and replace it if necessary. → Check that the installation is not shut-down. → Check that the power source is working properly. → If the problem occurs again, take contact with the retailer.

11.3.2 Resolution of problems related to an error message and the device state LED is red

Device state LED	Output DO4	Output DO1 and/or DO2 and/or DO3	Message displayed	Possible cause	Recommended action
red	0 Hz	not switched	"PWRFAIL"	The supply voltage is too low. The device does not function.	→ Check that the supply voltage is between 12 and 36 V DC. → If the problem occurs again, take contact with the retailer.
red	0 Hz		"ERROR3"	The user parameters are lost.	→ Start the device again. → If the message persists, configure the device again. → If the problem occurs again, take contact with the retailer.
red	10 Hz ¹⁾		"ERROR4"	The totalizer values are lost. The values saved upon the next to last power down are retrieved.	→ Start the device again. → If the problem occurs again, take contact with the retailer.
red	0 Hz		"ERROR5"	Both "ERROR3" and "ERROR4".	→ Start the device again. → If the message persists, configure the device again. → If the problem occurs again, take contact with the retailer.
red	10 Hz ¹⁾		"ERROR6"	Totalizers definitely lost. The totalizers are reset.	→ Start the device again. → If the problem occurs again, take contact with the retailer.
red	0 Hz		"ERROR7"	Both "ERROR3" and "ERROR6".	→ Start the device again. → If the message persists, configure the device again. → If the problem occurs again, take contact with the retailer.
red	10 Hz ¹⁾		dosing being done...	The rotational frequency of the paddle wheel is > 2,2 kHz.	→ Check the flow rate in the pipe. → If necessary, adjust the flow rate. → If the problem occurs again, take contact with the retailer.

¹⁾ If parameter "ERR. 10HZ" is set to "ACTIVE". See chap. [10.7.26](#).

11.3.3 Resolution of problems related to a warning message and the device state LED is orange

Device state LED	Output DO1 and/or DO2 and/or DO3	Message displayed	Possible cause	Recommended action
orange	Switched ²⁾	"WARN. LOW"	<p>During dosing, the measured flow rate has stayed under the minimum threshold for the set time delay.</p> <p>This message appears when the flow rate is monitored (see chap. 10.8.4).</p>	<ul style="list-style-type: none"> → Check the flow rate in the pipe and its consequences on the process. → If necessary, clean the flow sensor. → When the dosing is finished, access the Information menu and confirm the message. See chap. 10.10. → Check the connection between the device and the flow sensor.
orange	Switched ²⁾	"WARN. HIG"	<p>During a dosing, the measured flow rate has stayed above the maximum threshold for the set time delay.</p> <p>This message appears when the flow rate is monitored (see chap. 10.8.4).</p>	<ul style="list-style-type: none"> → Check the flow rate in the pipe and its consequences on the process. → If necessary, clean the flow sensor. → When the dosing is finished, access the Information menu and confirm the message. See chap. 10.10.
orange	Switched ²⁾	"W.OVER"	<p>The last dosing could not be correctly corrected and the dosed quantity has exceeded the threshold set in the overfill correction parameter (see chap. 10.7.15).</p>	<ul style="list-style-type: none"> → Check the process, and especially for the flow rate being stable. → Check the last dosing (missing liquid or overfilling). → If the problem occurs again after several dosings, use the function to smoothen the overfill correction. See chap. 10.7.15. → Access the Information menu and confirm the message. See chap. 10.10.
orange	Switched ²⁾	"WARN. VOL."	<p>The daily volume or mass totalizer has reached the value set in parameter "VOLUME-W." of the Test menu.</p>	<ul style="list-style-type: none"> → Do the planned maintenance operation. → Reset the daily volume or mass totalizer: see chap. 10.6 or 10.7.28.

Device state LED	Output DO1 and/or DO2 and/or DO3	Message displayed	Possible cause	Recommended action
orange	Switched ²⁾	"W. BATCH"	The number of done dosings has reached the value set in parameter "BATCH-W." of the Test menu.	<ul style="list-style-type: none"> → Do the planned maintenance operation. → Reset the daily totalizer of the done dosings: see chap. 10.6 or 10.7.29.

²⁾ If the output is configured to switch when a warning message is generated. See chap. [10.7.20](#).

11.3.4 Resolution of a problem occurring during a dosing

Device state LED	Output DO1 and/or DO2 and/or DO3	Output DO4 in "STATE" mode	Message displayed	Possible cause	Recommended action
orange, 3,5 Hz flashing	Switched ²⁾	3,5 Hz frequency	"ALARM"	<p>The message can appear if the generation of alarms during dosing is active on the device. See chap. 10.7.16.</p> <p>The device has opened the valves but there is no flow.</p>	<ul style="list-style-type: none"> → Check the process. → Check the operation of the valves. → Check the wiring of the valves, for example via the TEST menu. See chap. 10.8.2. → Check the flow sensor. → To confirm the message, press the key "ENTER" or send out a pulse on DI4: the dosing has been interrupted. current dosing can be continued or aborted.
orange, 3,5 Hz flashing	Switched ²⁾	3,5 Hz-frequency	"ALARM"	<p>The message can appear if the generation of alarms at the end of dosing is active on the device. See chap. 10.7.17.</p> <p>The device has closed the valves but there is still flow in the pipe.</p>	<ul style="list-style-type: none"> → Check the process. → Check the operation of the valves. → Check the wiring of the valves, for example via the TEST menu. See chap. 10.8.2. → Check the flow sensor. → To confirm the message, press the key "ENTER" or send out a pulse on DI4: if the dosing is finished, the device goes back to the Process level. Else, the dosing has been interrupted and can be continued or aborted.

MAN 1000199281 EN Version: C Status: RL (released | freigegeben) printed: 22.09.2017

Device state LED	Output DO1 and/or DO2 and/or DO3	Output DO4 in "STATE" mode	Message displayed	Possible cause	Recommended action
orange, 3,5 Hz flashing	Switched ²⁾	3,5 Hz-frequency	"ERROR [T]"	<p>The message can only appear if the dosing mode "EXT. [T]" is active.</p> <p>The dosing quantity is exceeded when the input DI1 has been deactivated.</p>	<p>→ Increase the values of the parameters A and B in order to reduce the activation time of the digital input DI1 and so that "$A \cdot T + B$" < flow rate times T.</p> <p>→ or set a time delay before the valves open. See chap. 10.7.24 and 10.7.25.</p> <p>→ or reduce the flow rate in the pipe.</p> <p>→ Confirm the message by pressing the key "ENTER" or by sending out a pulse on DI4: the current dosing is aborted.</p>
orange, 3,5 Hz flashing	Switched ²⁾	3,5 Hz-frequency	"ERROR [T]"	<p>The message can only appear if the dosing mode "EXT. [T]" is active.</p> <p>The dosing quantity, determined by the device depending on the activation duration of the digital input DI1, has exceeded the required thresholds.</p>	<p>→ Set the values of the parameters A and B and the value of the activation duration T so that "$A \cdot T + B$" < 100 000 and "$A \cdot T + B$" times the K-factor of the fitting used is higher or equal to 6.</p> <p>→ Set an activation duration $T < 300$ s.</p> <p>→ Confirm the message by pressing the key "ENTER" or by sending out a pulse on DI4: the current dosing is aborted.</p>

²⁾ If the output is configured to switch when an alarm is generated. See chap. [10.7.18](#).

11.3.5 Resolution of problems without message generation and the device status LED is green

Device state LED	Possible cause	Recommended action
green	During a dosing, the displayed quantity is increased or decreased very slowly.	→ Check that the K-factor corresponds to the fitting used. → Do a Teach-In procedure to determine the K-factor of the fitting used. → Check that the flow rate in the pipe is high enough.
green	The dosing does not start although the procedure has been correctly started: <ul style="list-style-type: none"> ▪ Either the dosing quantity times the set K-factor is lower than 6. ▪ Either the pipe diameter is too high for the dosing of small quantities. 	→ Set a dosing quantity that is higher or equal to 6 divided by the set K-factor. → Reduce the pipe diameter.
green	The display shows that the dosing has started (the units blink) but the valve connected to DO2 and/or DO3 does not open.	→ Check the value of the time delay before opening of the valves. → Check that the flow rate in the pipe is high enough.

11.3.6 Resolution of problems linked to warning messages not registered in the Information menu

Device state LED	Output DO4 in "STATE" mode	Message displayed	Possible cause	Recommended action
any colour	-	"PU L LIM"	The message is displayed after the pulse value has been entered (parameter "PU" of the transistor output DO1) or upon validation of the settings of the Parameters menu. The pulse value times the K-factor of the device is > 1000000. The quantity entered for a pulse is too high.	→ Enter a lower quantity per pulse. See chap. 10.7.22 .

MAN 1000199281 EN Version: C Status: RL (released | freigegeben) printed: 22.09.2017

Device state LED	Output DO4 in "STATE" mode	Message displayed	Possible cause	Recommended action
any colour	-	"PU H LIM"	<p>The message is displayed after the pulse value has been entered (parameter "PU" of the transistor output DO1) or upon validation of the settings of the Parameters menu.</p> <p>The pulse value times the K-factor of the device is < 1.</p> <p>The quantity entered for a pulse is too low.</p>	→ Enter a higher quantity per pulse. See chap. 10.7.22 .
any colour	flashes at a 10 Hz-frequency for 2 seconds after the device has been energized, then flashes at a 1 Hz-frequency	"CONTINUE"	The power supply has been cut during a dosing the dosing has been interrupted.	<p>→ Check the electrical installation.</p> <p>→ Abort the current dosing or continue the dosing; in that case check that the current dosing is correct.</p>
any colour	flashes at a 10 Hz-frequency for 2 s then flashes at a 1 Hz-frequency	Process level	The power supply has been cut during the consultation of the messages of the Information menu via the digital inputs.	→ Check that the PLC knows that the device has returned to the Process level.

12 SPARE PARTS AND ACCESSORIES

ATTENTION

Risk of injury and/or damage caused by the use of unsuitable parts.

Incorrect accessories and unsuitable replacement parts may cause injuries and damage the device and the surrounding area.

- ▶ Use only original accessories and original replacement parts from Bürkert.

The damaged electronic board or housing can be replaced.

- Contact your local Bürkert sales office.

Spare part for 8025 Batch in panel version		Order code
	Mounting set (screws, washers, nuts, cable clips) (positions 1, 2, 3, 4)	554 807
	Seal (position 5)	419 350
	Set with 8 FLOW foils	553 191
Spare part for 8025 Batch in wall-mounting version		Order code
	Power supply board 115/230 VAC + mounting instruction sheet	555 722

Spare part for the 8025 Batch in compact version		Order code
	Electronic board mounted in the cover with lid, with window, foil and four screws (position 1)	425 432
	Power supply board 115/230 VAC (position 2) + mounting instruction sheet	553 168
	Set including:	
	▪ two M20x1,5 cable glands (position 3)	
	▪ two neoprene flat seals (position 5) for cable gland or screw plug	449 755
	▪ two M20x1.5 screw plugs (position 6)	
	▪ two 2x6 mm multiway seals (position 8)	
	Set including:	
	▪ two M20x1,5 / NPT1/2" reductions (mounted o-ring seal) (position 4)	551 782
	▪ two neoprene flat seals for plug (position 5)	
	▪ two M20x1.5 screw plugs (position 6)	
	Set including:	
	▪ one M20x1,5 cable gland stopper gasket (position 7)	551 775
	▪ one multiway seal, 2x6 mm, for cable gland (position 8)	
▪ one black EPDM seal (position 12) for the flow sensor		
▪ one mounting instruction sheet		
Housing (position 9) with snap ring and nut	425 526	
Snap ring (position 10)	619 205	
Nut (position 11)	619 204	
Set including:		
▪ one black EPDM seal (position 12) for the flow sensor	552 111	
▪ one green FKM seal (position 12) for the flow sensor		
Short flow sensor, Hall effect (position 13)	418 316	
Long flow sensor, Hall effect (position 14)	418 324	
Set with 8 FLOW foils	553 191	

Spare part for the 8035 Batch and the SE35 Batch		Order code
	Electronic board mounted in the cover with lid, with window, foil and four screws (position 1)	425 432
	Power supply board 115/230 VAC (position 2) + mounting instruction sheet	553 168
	Set including: <ul style="list-style-type: none"> two M20x1,5 cable glands (position 3) two neoprene flat seals (position 5) for cable gland or screw plug two M20x1.5 screw plugs (position 6) two 2x6 mm multiway seals (position 8) 	449 755
	Set including: <ul style="list-style-type: none"> two M20x1,5 / NPT1/2" reductions (mounted o-ring seal) (position 4) two neoprene flat seals for plug (position 5) two M20x1.5 screw plugs (position 6) 	551 782
	Set including: <ul style="list-style-type: none"> one M20x1,5 cable gland stopper gasket (position 7) one multiway seal, 2x6 mm, for cable gland (position 8) one black EPDM seal (unused) one mounting instruction sheet 	551 775
	Housing (position 9) with Hall effect flow sensor	425 248
	Set with 8 FLOW foils	553 191

MAN 1000199281 EN Version: C Status: RL (released | freigegeben) printed: 22.09.2017

13 PACKAGING, TRANSPORT

NOTE

Damage due to transport

Transport may damage an insufficiently protected device.

- ▶ Transport the device in shock-resistant packaging and away from humidity and dirt.
- ▶ Do not expose the device to temperatures that may exceed the admissible storage temperature range.
- ▶ Protect the electrical interfaces using protective plugs.

14 STORAGE

NOTE

Poor storage can damage the device.

- ▶ Store the device in a dry place away from dust.
- ▶ Storage temperature of the device: $-10\dots+60^{\circ}\text{C}$.

15 DISPOSAL OF THE DEVICE

→ Dispose of the device and its packaging in an environmentally-friendly way.

NOTE

Damage to the environment caused by parts contaminated by the fluid.

- ▶ Comply with the national and/or local regulations which concern the area of waste disposal.

