

Type 8696

Positioner Top Control Basic

Electropneumatic Position Controller



Operating Instructions

We reserve the right to make technical changes without notice.
Technische Änderungen vorbehalten.
Sous réserve de modifications techniques.

© Bürkert Werke GmbH & Co. KG, 2008 - 2021

Operating Instructions 2111/10_EN-EN_00805905 / Original DE

Positioner Type 8696

TABLE OF CONTENTS

1	OPERATING INSTRUCTIONS.....	7
1.1	Symbols	7
1.2	Definition of term / abbreviation	7
2	AUTHORIZED USE	8
2.1	Restrictions	8
3	BASIC SAFETY INSTRUCTIONS.....	9
4	GENERAL INFORMATION.....	10
4.1	Contact address	10
4.2	Warranty	10
4.3	Trademarks	10
4.4	Information on the internet.....	10
5	SYSTEM DESCRIPTION	11
5.1	Designated application area	11
5.2	Function of the positioner and combination with valve types.....	11
5.3	Features of the valve types	12
5.4	Model for control of third-party devices.....	13
5.5	Structure of the positioner	14
5.5.1	Representation.....	14
5.5.2	Features.....	15
5.5.3	Functional diagram of the positioner with single-acting actuator	16
5.6	Type 8696 positioner.....	17
5.6.1	Schematic representation of the position control Type 8696.....	17
5.6.2	Functions of the positioner software.....	18
5.7	Interfaces of the positioner	20

6	TECHNICAL DATA.....	21
6.1	Conformity.....	21
6.2	Standards.....	21
6.3	Licenses.....	21
6.4	Operating conditions	21
6.5	Mechanical data.....	21
6.6	Pneumatic data	22
6.7	Type label	22
6.8	UL additional label.....	23
6.9	Electrical data	23
6.10	Factory settings of the positioner	24
7	CONTROL AND DISPLAY ELEMENTS.....	25
7.1	Operating status.....	25
7.2	Control and display elements of the positioner	25
7.3	Configuration of the keys.....	26
7.4	Function of the DIP switches.....	28
7.5	Display of the LEDs.....	30
7.6	Error messages	31
7.6.1	Error messages in MANUAL and AUTOMATIC operating statuses	31
7.6.2	Error messages while the X.TUNE function is running	31
8	INSTALLATION	32
8.1	Safety instructions	32
8.2	Installation of the positioner Type 8696 to process valves of series 2103, 2300 and 2301	32
8.3	Rotating the actuator module for process valves belonging to series 2300 and 2301.....	36
9	PNEUMATIC INSTALLATION.....	38
10	ELECTRICAL INSTALLATION 24 V DC.....	40
10.2	Electrical installation with circular plug-in connector.....	41

10.2.1	Designation of the contacts Type 8696.....	41
10.2.2	Connection of the positioner Type 8696.....	41
11	START-UP	43
11.1	Safety instructions	43
11.2	Specifying the standard settings.....	43
11.2.1	Running the automatic adjustment X.TUNE	43
12	OPERATION AND FUNCTION	45
12.1	Basic functions	45
12.1.1	DIR.CMD - Effective direction of the positioner set-point value	46
12.1.2	CUTOFF - Sealing function for the positioner	47
12.1.3	CHARACT - Select the transfer characteristic between input signal (position set-point value) and stroke.....	48
12.1.4	INPUT - Enter the input signal.....	50
12.1.5	RESET - Reset to factory settings.....	51
12.1.6	X.TUNE - Automatic adjustment of the positioner to the relevant operating conditions.....	51
12.2	Auxiliary functions.....	52
12.2.1	DIR.ACTUATOR - Effective direction of the actuator.....	52
12.2.2	SPLITRANGE - Signal split range.....	53
12.2.3	X.LIMIT - Limiting the mechanical stroke range	54
12.2.4	X.TIME - Limiting the control speed.....	55
12.2.5	X.CONTROL - Parameterization of the positioner.....	56
12.2.6	SAFE POSITION - Definition of the safe position.....	56
12.2.7	SIGNAL ERROR - Configuration of signal level fault detection	57
12.2.8	BINARY INPUT - Activation of the binary input	57
12.2.9	OUTPUT (optional) - Configuration of the analog output	58

13	SAFETY END POSITIONS	59
	13.1 Safety end positions after failure of the electrical or pneumatic auxiliary power.....	59
14	MAINTENANCE	59
15	DISASSEMBLY	60
	15.1 Safety instructions	60
	15.2 Disassembly the positioner.....	60
16	ACCESSORIES	62
	16.1 Communications software.....	62
	16.1.1 USB interface.....	62
	16.1.2 Download	62
17	PACKAGING AND TRANSPORT	63
18	STORAGE	63
19	DISPOSAL	63

1 OPERATING INSTRUCTIONS

The operating instructions describe the entire life cycle of the device. Keep these instructions in a location which is easily accessible to every user and make these instructions available to every new owner of the device.

Important safety information.

Read the operating instruction carefully and thoroughly. Study in particular the chapters entitled "[Basic safety instructions](#)" and "[Authorized use](#)".

- ▶ The operating instructions must be read and understood.

1.1 Symbols



DANGER!

Warns of an immediate danger.

- ▶ Failure to observe the warning may result in a fatal or serious injury.



WARNING!

Warns of a potentially dangerous situation.

- ▶ Failure to observe the warning may result in serious injuries or death.



CAUTION!

Warns of a possible danger.

- ▶ Failure to observe this warning may result in a moderately severe or minor injury.

NOTE!

Warns of damage to property.

1. Failure to observe the warning may result in damage to the device or the equipment.



Indicates important additional information, tips and recommendations.



refers to information in these operating instructions or in other documentation.

- ▶ Designates an instruction to prevent risks.

→ Designates a procedure which you must carry out.

1.2 Definition of term / abbreviation

The term "device" used in these instructions always stands for the positioner Type 8696.

In these instructions, the abbreviation "Ex" always refers to "potentially explosive atmosphere".

2 AUTHORIZED USE

Incorrect use of the positioner Type 8696 may be a hazard to people, nearby equipment and the environment.

- ▶ The device is designed to be mounted on pneumatic actuators of process valves for the control of media.
- ▶ Do not expose the device to direct sunlight.
- ▶ Use according to the permitted data, operating conditions and conditions of use specified in the contract documents and operating instructions. These are described in the chapter entitled "[6 Technical data](#)".
- ▶ The device may be used only in conjunction with third-party devices and components recommended and authorized by Bürkert.
- ▶ In view of the large number of options for use, before installation, it is essential to study and if necessary to test whether the positioner is suitable for the actual use planned.
- ▶ Correct transportation, correct storage and installation and careful use and maintenance are essential for reliable and problem-free operation.
- ▶ Use the positioner Type 8696 only as intended.

2.1 Restrictions

If exporting the system/device, observe any existing restrictions.

3 BASIC SAFETY INSTRUCTIONS

These safety instructions do not make allowance for any

- contingencies and events which may arise during the installation, operation and maintenance of the devices.
- local safety regulations; the operator is responsible for observing these regulations, also with reference to the installation personnel.



DANGER!

Risk of injury from high pressure in the equipment/device.

- ▶ Before working on equipment or device, switch off the pressure and deaerate/drain lines.

Risk of electric shock.

- ▶ Before working on equipment or device, switch off the power supply and secure to prevent reactivation.
- ▶ Observe applicable accident prevention and safety regulations for electrical equipment.

General hazardous situations.

To prevent injury, ensure that:

- ▶ In the potentially explosive atmosphere the positioner Type 8696 may be used only according to the specification on the separate approval sticker. For use observe the additional instructions enclosed with the device together with safety instructions for the potentially explosive atmosphere.
- ▶ Devices without a separate approval sticker may not be used in a potentially explosive atmosphere.
- ▶ The system cannot be activated unintentionally.
- ▶ Installation and repair work may be carried out by authorised technicians only and with the appropriate tools.
- ▶ After an interruption in the power supply or pneumatic supply, ensure that the process is restarted in a defined or controlled manner.
- ▶ The device may be operated only when in perfect condition and in consideration of the operating instructions.
- ▶ The general rules of technology apply to application planning and operation of the device.

To prevent damage to property of the device, ensure:

- ▶ Do not feed any aggressive or flammable media into the pilot air port.
- ▶ Do not feed any liquids into the pilot air port.
- ▶ When unscrewing and screwing in the body casing or the transparent cap, do not hold the actuator of the process valve but the connection housing of Type 8696.
- ▶ Do not put any loads on the body (e.g. by placing objects on it or standing on it).
- ▶ Do not make any external modifications to the device bodies.

NOTE!

Electrostatic sensitive components / modules.

The device contains electronic components which react sensitively to electrostatic discharge (ESD). Contact with electrostatically charged persons or objects is hazardous to these components. In the worst case scenario, they will be destroyed immediately or will fail after start-up.

- ▶ Observe the requirements in accordance with EN 100 015 - 1 to minimise or avoid the possibility of damage caused by sudden electrostatic discharge.
- ▶ Also ensure that you do not touch electronic components when the power supply voltage is present.

4 GENERAL INFORMATION

4.1 Contact address

Germany

Bürkert Fluid Control System
Sales Centre
Chr.-Bürkert-Str. 13-17
D-74653 Ingelfingen
Tel. + 49 (0) 7940 - 10 91 111
Fax + 49 (0) 7940 - 10 91 448
E-mail: info@burkert.com

International

Contact addresses can be found on the final pages of the printed operating instructions.

And also on the internet at:

www.burkert.com

4.2 Warranty

The warranty is only valid if the positioner Type 8696 is used as intended in accordance with the specified application conditions.

4.3 Trademarks

Brands and trademarks listed below are trademarks of the corresponding companies / associations / organizations

Loctite Henkel Loctite Deutschland GmbH

4.4 Information on the internet

The operating instructions and data sheets for Type 8696 can be found on the Internet at:

www.burkert.com

5 SYSTEM DESCRIPTION

5.1 Designated application area

The positioner Type 8696 is designed to be mounted on pneumatic actuators of process valves for the control of media.

5.2 Function of the positioner and combination with valve types

Positioner Type 8696 is an electropneumatic position controller for pneumatically actuated control valves with single-acting actuators.

Together with the pneumatic actuator, the positioner forms a functional unit.

The control valve systems can be used for a wide range of control tasks in fluid technology and, depending on the application conditions, different process valves from the Bürkert range can be combined with the positioner. Angle seat valves, straight seat valves or diaphragm valves of the Type 2300, 2301 or 2103 with an actuator size of 50 mm are suitable.

“Figure 1” shows an overview of the possible combinations of positioner and different pneumatically actuated valves. Different valve orifices, not illustrated here, are available for each type. More precise specifications can be found on the respective data sheets. The product range is being continuously expanded.

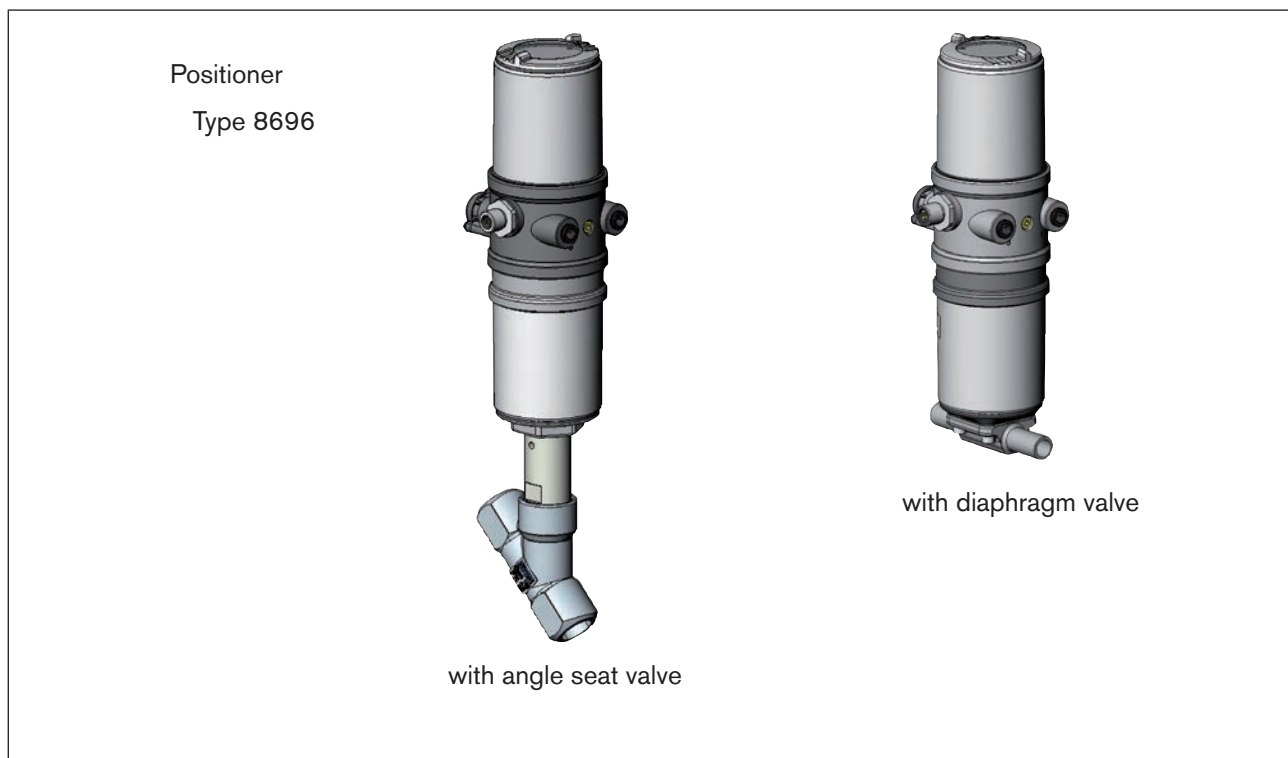

Figure 1: Overview of possible combinations

The position of the actuator is regulated according to the position set-point value. The nominal position value is specified by an external standard signal.

Pneumatically actuated piston actuators and rotary actuators can be used as an actuator. Single-acting actuators are offered in combination with the positioner.

For single-acting actuators, only one chamber is aerated and deaerated during actuation. The generated pressure works against a spring. The piston moves until there is an equilibrium of forces between compressive force and spring force.

5.3 Features of the valve types

	Angle seat control valves / Straight seat control valves	Diaphragm Valves
Types	<ul style="list-style-type: none"> ▪ 2300 ▪ 2301 	<ul style="list-style-type: none"> ▪ 2103
Features	<ul style="list-style-type: none"> ▪ incoming flow under seat ▪ no pressure surges when closing the valve ▪ straight flow path of the medium ▪ self-adjusting packing gland for high leak-tightness 	<ul style="list-style-type: none"> ▪ medium is hermetically separated from the actuator and environment ▪ cavity-free and self-draining body design ▪ any flow direction with low-turbulence flow ▪ steam-sterilizable ▪ CIP-compliant ▪ no pressure surges when closing the valve ▪ actuator and diaphragm can be removed when the housing is installed
Typical media	<ul style="list-style-type: none"> ▪ water, steam and gases ▪ alcohols, oils, propellants, hydraulic fluids ▪ salt solutions, lyes (organic) ▪ solvents 	<ul style="list-style-type: none"> ▪ neutral gases and liquids ▪ contaminated, abrasive and aggressive media ▪ media of higher viscosity

Table 1: Features of the valve types

5.4 Model for control of third-party devices

A special model enables the positioner Type 8696 to be attached to third-party devices.

This model has a different pneumatic connection housing so that the pilot air ports can be connected to the outside of the actuator.

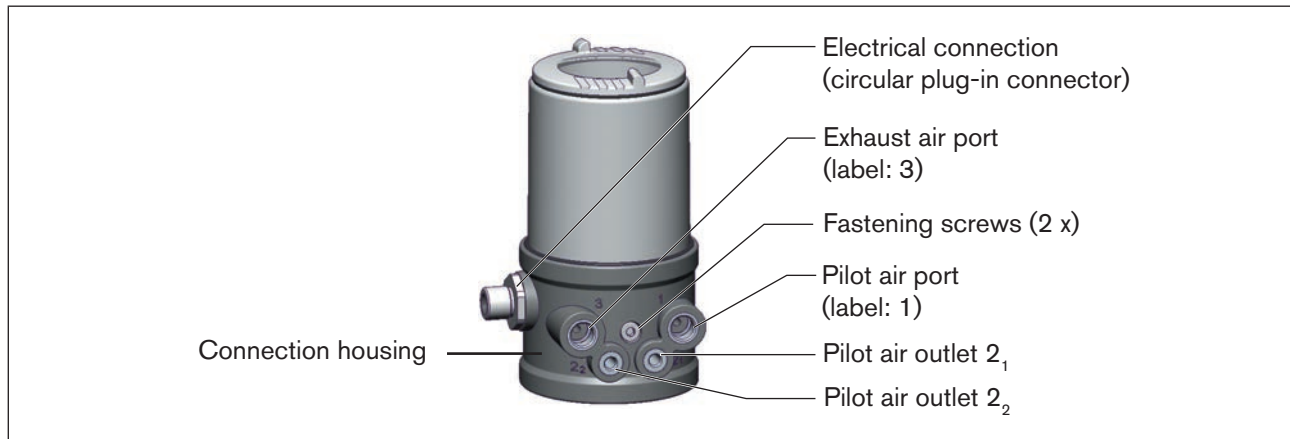

Figure 2: Model for third-party devices

NOTE!

Damage or malfunction due to ingress of dirt and moisture.

- ▶ To comply with degree of protection IP65 / IP67, connect the pilot air outlet (only for CFA or CFB) which is not required to the free pilot air port of the third-party device or seal with a plug.



“In rest position” means that the pilot valves of the positioner Type 8696 are isolated or not actuated.



If the ambient air is humid, a hose can be connected between pilot air outlet 2₂ of the positioner and the unconnected pilot air port of the third-party device for control function A or control function B. As a result, the spring chamber of the third-party device is supplied with dry air from the vent duct of the positioner.

Control function (CF)		Pneumatic connection Type 8696 with third-party device
A	Process valve closed in rest position (by spring force)	
B	Process valve open in rest position (by spring force)	

Table 2: Pneumatic connection to third-party device

¹⁾ Connection optionally, see note.

5.5 Structure of the positioner

The positioner Type 8696 consists of the micro-processor controlled electronics, the position measuring system and the control system.

The appliance is designed using three-wire technology. The operation of the positioner takes place via 2 keys and a 4-pole DIP switch.

The pneumatic control system for single-acting actuators consists of two solenoid valves.

5.5.1 Representation

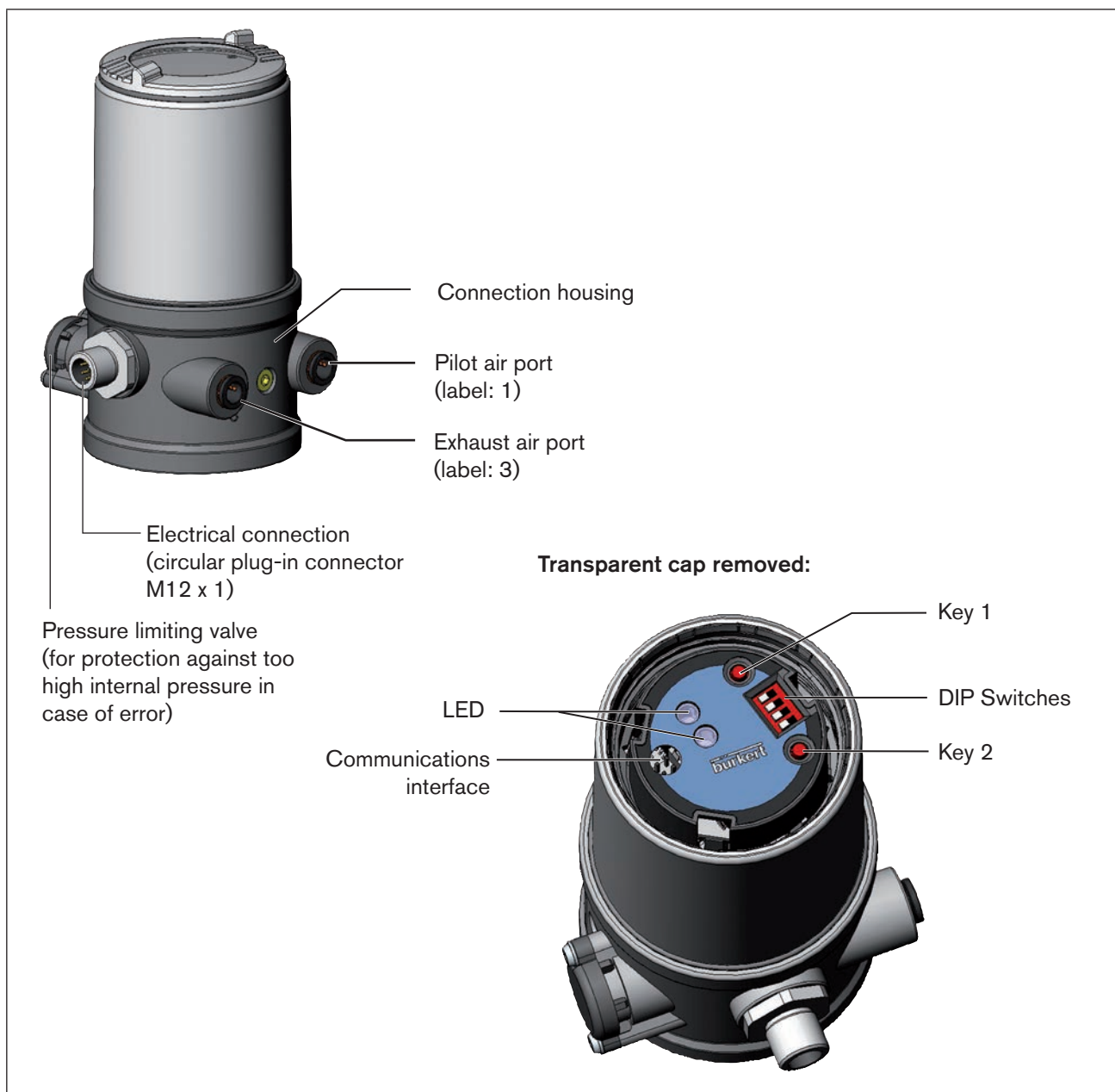

Figure 3: Structure

5.5.2 Features

- **Models**
for single-acting valve actuators.
- **Position measuring system**
Non-contact and therefore non-wearing position measuring system.
- **Microprocessor-controlled electronics**
for signal processing, control and valve control.
- **Control module**
The operation of the device takes place via 2 keys and a 4-pole DIP switch. 2 2-colored LEDs allow various status displays of the device.
- **Control system**
The control system consists of 2 solenoid valves. One valve is used to aerate and another to deaerate the pneumatic actuator. The solenoid valves operate according to the rocker principle and are controlled with a PWM voltage via the controller. Doing so achieves a higher flexibility with regard to actuator volume and final control speed. The direct-action model has an orifice of DN 0.6.
- **Position feedback (optional)**
The position of the valve can be relayed to the PLC via an analogue 0/4 – 20 mA output.
- **Binary input**
If a voltage > 10 V is applied, *SAFE POSITION* is activated, i.e. the valve is moved to the safety position (factory setting, can be changed with communications software).
- **Pneumatic interfaces**
hose plug-in connection \varnothing 6 mm / 1/4"
on request: threaded port
- **Electrical interfaces**
Circular plug-in connection
- **Body**
The body of the positioner is protected from excessively high internal pressure, e.g. due to leaks, by a pressure limiting valve.
- **Communications interface**
For configuration and parameterization.



5.5.3 Functional diagram of the positioner with single-acting actuator

The displayed functional diagram describes the function of the positioner (Type 8696).

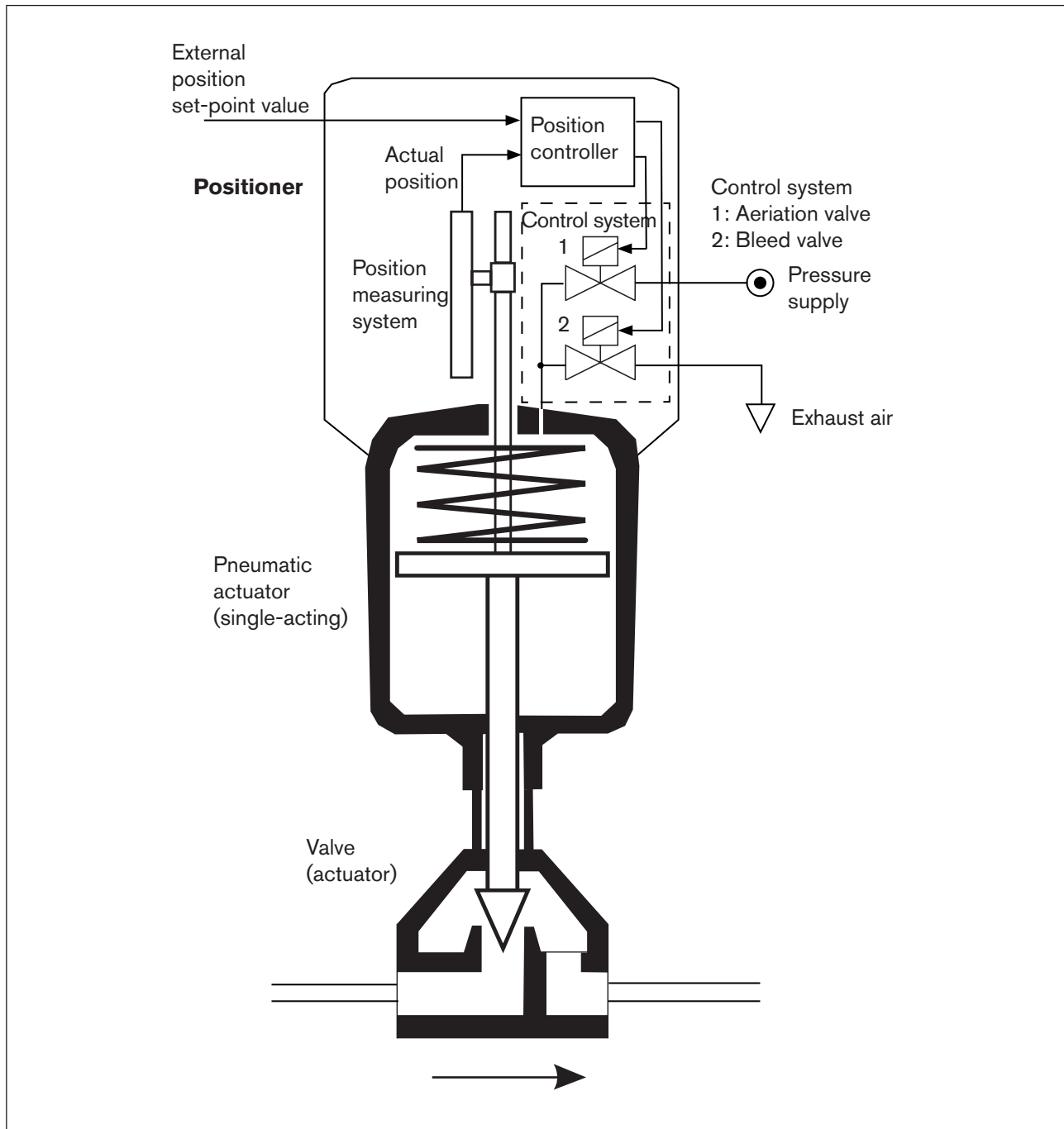

Figure 4: Function diagram

5.6 Type 8696 positioner

The position measuring system records the current position (*POS*) of the pneumatic actuator. The positioner compares this actual position value with the set-point value (*CMD*), which is definable as norm signal. In case of a control deviation (*Xd1*), a pulse-width modulated voltage signal is sent to the control system as a manipulated variable. If there is a positive control difference in single-acting actuators, the air inlet valve is controlled via output B1. If the control difference is negative, the bleed valve is controlled via output E1. In this way the position of the actuator is changed until control difference is 0. *Z1* represents a disturbance variable.

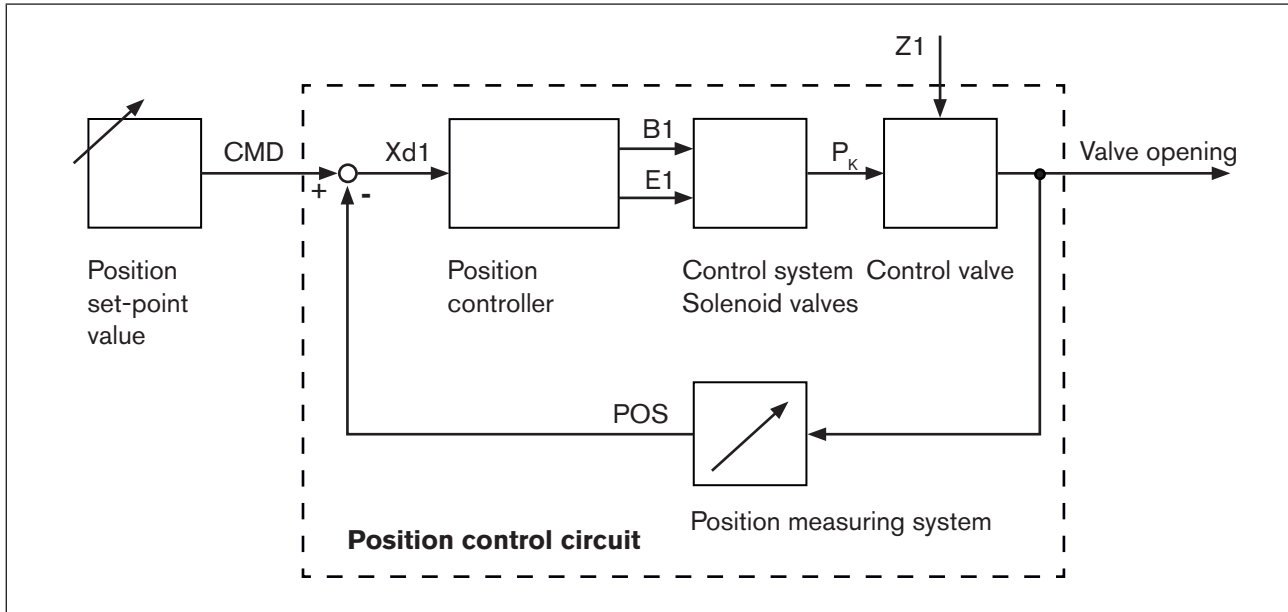

Figure 5: Signal flow plan of positioner

5.6.1 Schematic representation of the position control Type 8696

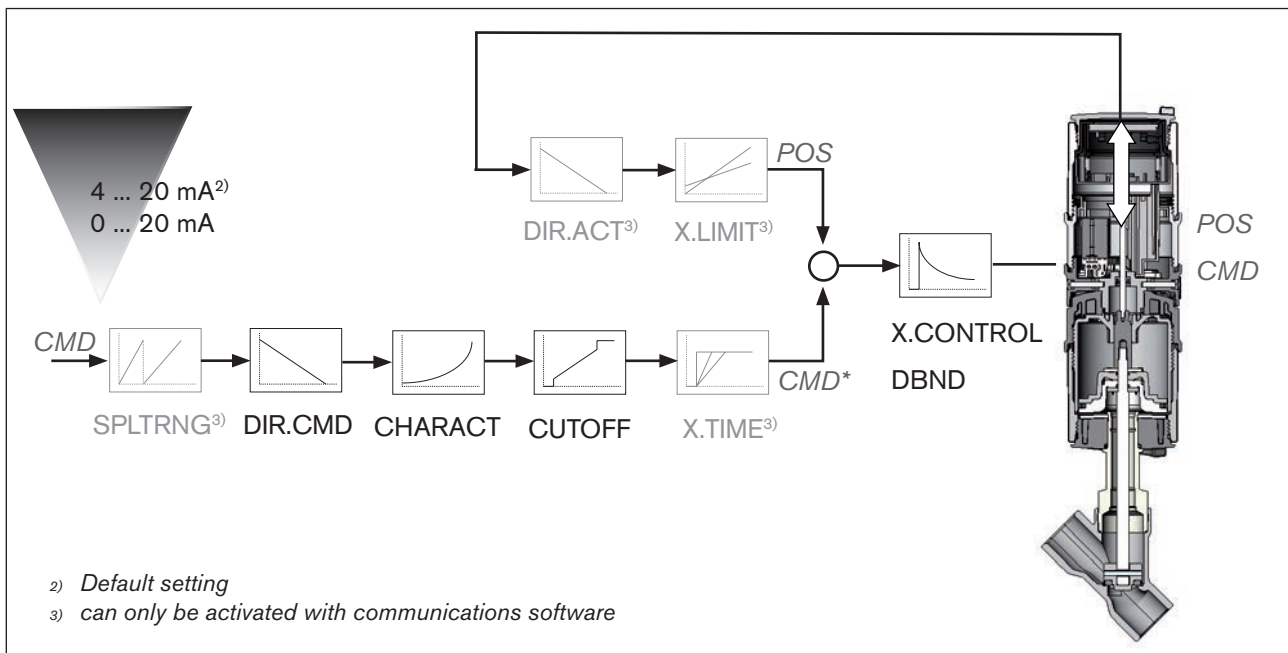

Figure 6: Schematic representation of the position control

5.6.2 Functions of the positioner software

Functions I

- Activation via DIP switches
- Parameter setting via communications software

Additional function	Effect
Sealing function <i>CUTOFF</i>	Valve closes tight outside the control range. Specification of the value (as %), from which the actuator is completely deaerated (when 0 %) or aerated (when 100 %) (see chapter “7.4 Function of the DIP switches”).
Correction line to adjust the operating characteristic <i>CHARACT</i>	Linearization of the operating characteristic can be implemented (see chapter “7.4 Function of the DIP switches”).
Effective direction of the controller set-point value <i>DIR.CMD</i>	Reversal of the effective direction of the set-point value (see chapter “7.4 Function of the DIP switches”).

Table 3: *Functions I*

Functions II

- Activation and parameter setting via communications software

Additional function	Effect
Standard signal for set-point value <i>INPUT</i>	Select set-point value standard signal
Effective direction of the actuator <i>DIR.ACTUATOR</i>	Assignment of the aeration status of the actuator chamber to the actual position.
Signal split range <i>SPLITRANGE</i>	Standard signal as % for which the valve runs through the entire mechanical stroke range.
Mechanical stroke range limit <i>X.LIMIT</i>	Limit the mechanical stroke range
Opening and closing time <i>X.TIME</i>	Limit the control speed
Positioner <i>X.CONTROL</i>	Parameterize the positioner
Safety position <i>SAFE POSITION</i>	Definition of the safety position
Signal level fault detection <i>SIGNAL ERROR</i>	Configuration of signal level fault detection
Binary input <i>BINARY INPUT</i>	Configuration of the binary input
Analog output <i>OUTPUT</i>	Configuration of the analog output (optional)
Reset <i>RESET</i>	Reset to factory settings

Table 4: Functions II

5.7 Interfaces of the positioner

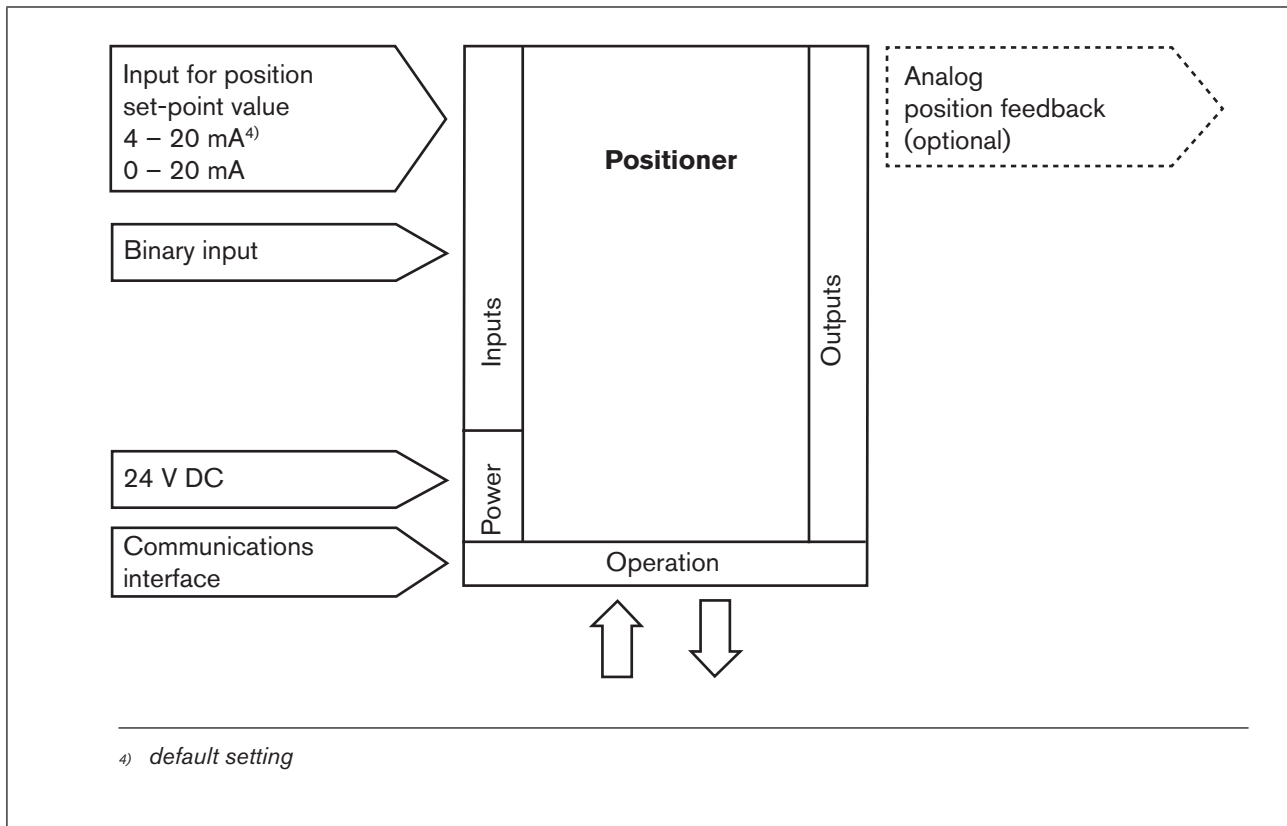

Figure 7: Interfaces



The positioner Type 8696 is a 3-wire device, i.e. the power (24 V DC) is supplied separately from the set-point value signal.

- Input for position set-point value (4 – 20 mA corresponds to 0 – 100%) (depending on the position of DIP switch 1)
- Binary input
If a voltage > 10 V is applied, *SAFE POSITION* is activated, i.e. the valve is moved to the safety position (factory setting, can be changed with communications software)
- Analog position feedback (optional)
The position of the valve can be transmitted via an analog 4 – 20 mA output to the PLC (4 – 20 mA corresponds to 0 – 100%)

6 TECHNICAL DATA

6.1 Conformity

In accordance with the EU Declaration of conformity, the positioner Type 8696 is compliant with the EU Directives.

6.2 Standards

The applied standards, which verify conformity with the EU Directives, can be found on the EU-Type Examination Certificate and / or the EU Declaration of Conformity.

6.3 Licenses

The product is approved for use in zone 2 and 22 in accordance with ATEX directive 2014/34/EU category 3GD.



Observe instructions on operation in a potentially explosive atmosphere.
Observe the ATEX additional instructions.

The product is cULus approved. Instructions for use in the UL area see chapter [“6.9 Electrical data”](#).

6.4 Operating conditions



WARNING!

Solar radiation and temperature fluctuations may cause malfunctions or leaks.

- ▶ If the device is used outdoors, do not expose it unprotected to the weather conditions.
- ▶ Ensure that the permitted ambient temperature does not exceed the maximum value or drop below the minimum value.

Ambient temperature: See type label

Degree of protection:

Evaluated by the manufacturer:	Evaluated by UL:
IP65 / IP67 according to EN 60529 ⁵⁾	UL Type 4x Rating, indoor only ⁵⁾

Operating altitude: up to 2000 m above sea level

Relative air humidity max. 90% at 55 °C (non condensing)

⁵⁾ Only if cables, plugs and sockets have been connected correctly and in compliance with the exhaust air concept, see chapter [“9 Pneumatic installation”](#).

6.5 Mechanical data

Dimensions		See data sheet
Body material	exterior: interior:	PPS, PC, VA, PA 6; ABS
Sealing material		EPDM / FKM
Stroke range of valve spindle:		2103 and 23xx series: 3 – 32 mm
		Third-party devices: (modified guide element required) 3 – 40 mm

6.6 Pneumatic data

Control medium		neutral gases, air Quality classes in accordance with ISO 8573-1
Dust content	Quality class 7	max. particle size 40 µm, max. particle density 10 mg/m ³
Water content	Quality class 3	max. pressure dew point - 20 °C or min. 10 °C below the lowest operating temperature
Oil content	Quality class X	max. 25 mg/m ³
Temperature range of the control medium		-10 – + 50 °C
Pressure range of the control medium		3 – 7 bar
Air output, pilot valve		7 I _N /min (for aeration and deaeration) (Q _{Nn} value according to definition for pressure drop from 7 to 6 bar absolute)
Connections 23xx / 2103 (Element)		Plug-in hose connector Ø 6 mm / 1/4" Threaded port G1/8
Model third-party device:		Socket connection G 1/8 with M5 connection for connecting to the third-party device

6.7 Type label

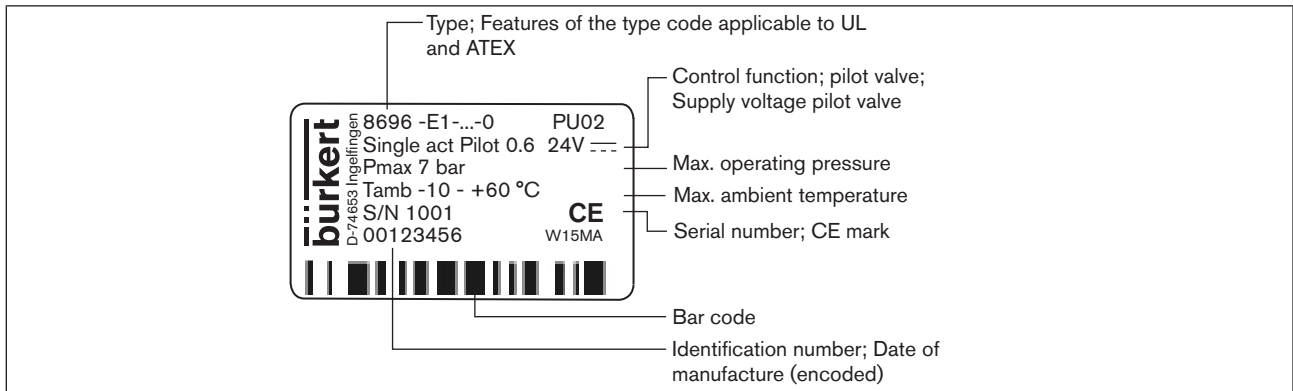

Figure 8: Example of type label

6.8 UL additional label

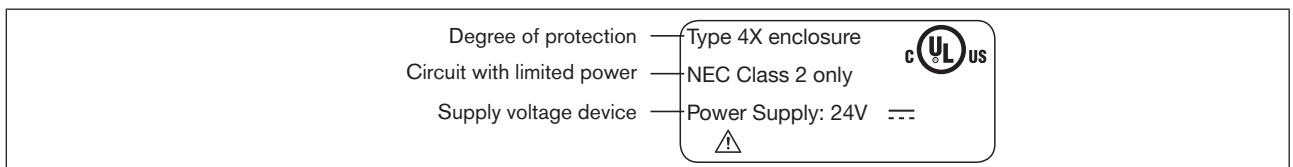

Figure 9: UL additional label (example)

6.9 Electrical data

WARNING!

Only circuits with limited power may be used for UL approved components according to “NEC Class 2”.

Connections	Circular plug-in connector (M12 x 1, 8-pole)
Pilot valve	
Operating voltage	24 V DC ± 10% - max. residual ripple 10 %
Power input	≤ 3.5 W
Input resistance for set-point value signal	180 Ω at 0/4 – 20 mA / 12 bit resolution
Protection class	III as per DIN EN 61140 (VDE 0140-1)
Analogue position feedback max. load for current output 0/4 – 20 mA	560 Ω
Binary input	0 – 5 V = log "0", 12 – 30 V = log "1" inverted input in reverse order
Communications interface	Direct connection to PC via USB adapter with integrated interface driver, communication with communications software, see “Table 25: Accessories”

6.10 Factory settings of the positioner

Functions can be activated via DIP switches:

Function	Parameter	Value
<i>CUTOFF</i>	Sealing function below Sealing function above	2 % 98 %
<i>CHARACT</i>	Select characteristic	FREE ⁶⁾
<i>DIR.CMD</i>	Effective direction set-point value	rise

Table 5: Factory settings - functions I

Functions can be activated via communications software:

Function	Parameter	Value
<i>INPUT</i>	Set-point value input	4 ... 20 mA
<i>DIR.ACTUATOR</i>	Effective direction actual value	rise
<i>SPLITRANGE</i> Function deactivated	Signal split range below Signal split range above	0 % 100 %
<i>X.LIMIT</i> Function deactivated	Stroke limit below Stroke limit above	0 % 100 %
<i>X.TIME</i> Function deactivated	Actuating time Open Actuating time Closed	(1 s) values determined by <i>X.TUNE</i> (1 s) values determined by <i>X.TUNE</i> After implementation of <i>RESET</i> : 1 s
<i>X.CONTROL</i>	Deadband Open amplification factor Close amplification factor	2,0 % (1) values determined by <i>X.TUNE</i> (1) values determined by <i>X.TUNE</i> After implementation of <i>RESET</i> : 1
<i>SAFE POSITION</i>	Safety position	0 %
<i>SIGNAL ERROR</i> Function deactivated	Sensor break detection set-point value	OFF
<i>BINARY INPUT</i>	Binary input function Operating principle of binary input	Safety position Normally open
<i>OUTPUT</i> (optional)	Norm signal output: Parameter Norm signal output: Type	Position 4 – 20 mA

Table 6: Factory settings functions II

⁶⁾ without change to the settings via the communications software a linear characteristic is stored in *FREE*.

7 CONTROL AND DISPLAY ELEMENTS

The following chapter describes the operating statuses as well as the control and display elements of the positioner.

For further information on the operation of the positioner, refer to chapter [“11 Start-up”](#).

7.1 Operating status

AUTOMATIC (AUTO)

Normal controller mode is implemented and monitored in AUTOMATIC operating state.

→ LED1 flashes green.

MANUAL (MANU)

In MANUAL operating state the valve can be opened and closed manually via the keys.

→ LED1 flashes red / green alternately.

The DIP switch 4 can be used to switch between the two operating states AUTOMATIC and MANUAL.

7.2 Control and display elements of the positioner

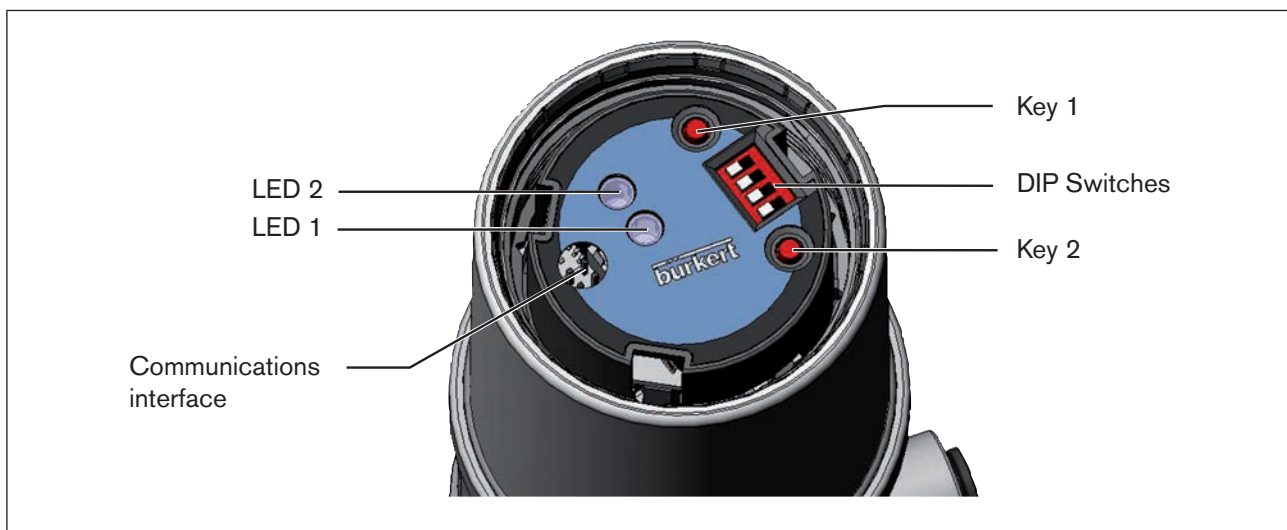

Figure 10: Description of the control elements

The positioner features two keys, a 4-pole DIP switch and 2 2-colored LEDs as a display element.

NOTE!

Breakage of the pneumatic connection pieces due to rotational impact.

- ▶ When unscrewing and screwing in the transparent cap, do not hold the actuator of the process valve but the connection housing.

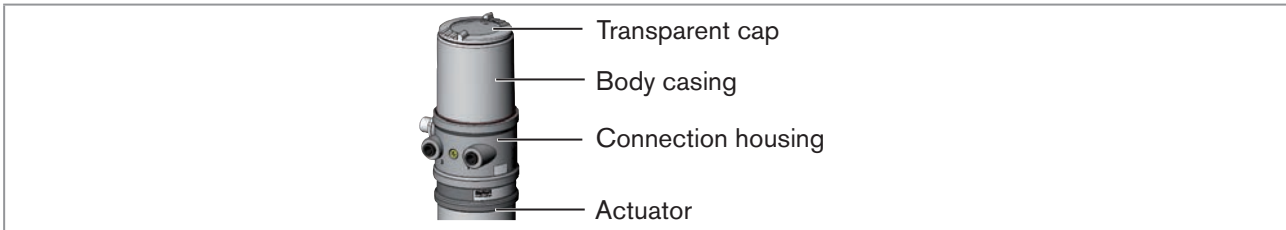

Figure 11: Open positioner

→ Screw off the transparent cap of the positioner to operate the keys and DIP switches.

NOTE!

Damage or malfunction due to penetration of dirt and humidity.

- ▶ To observe degree of protection IP65 / IP67, screw the transparent cap in all the way.

→ Close the device (assembly tool: 674078⁷⁾).

7.3 Configuration of the keys

The configuration of the 2 keys on the board varies depending on the operating status (AUTOMATIC / MANUAL).

The description of the operating statuses (AUTOMATIC / MANUAL) can be found in the chapter entitled [“7.1 Operating status”](#).

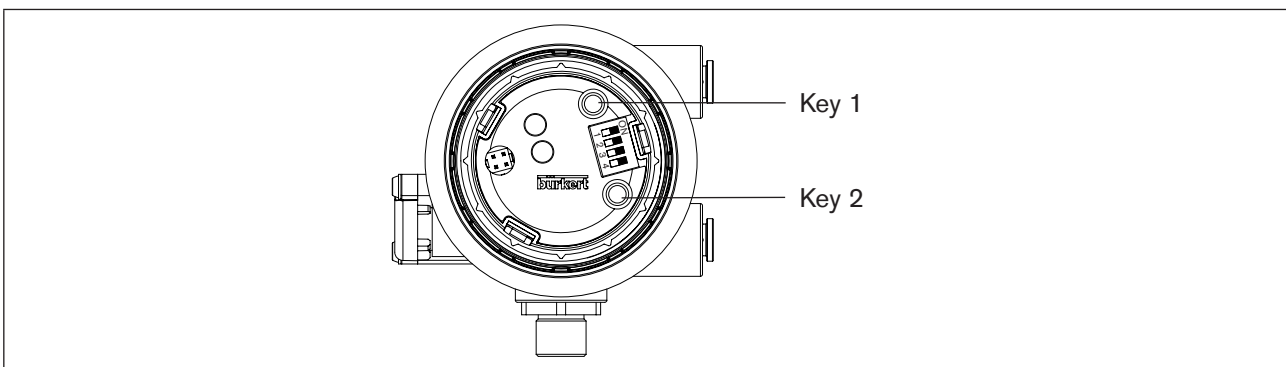

Figure 12: Description of the keys

NOTE!

Breakage of the pneumatic connection pieces due to rotational impact.

- ▶ When unscrewing and screwing in the transparent cap, do not hold the actuator of the process valve but the connection housing.

→ To operate the keys unscrew the transparent cap.

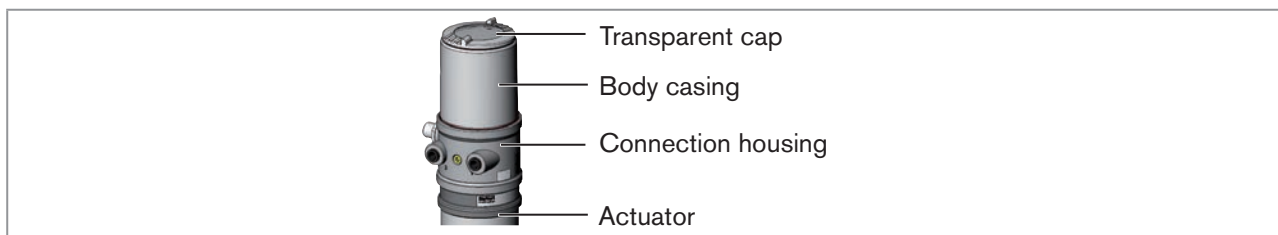

Figure 13: Open positioner

NOTE!

Damage or malfunction due to penetration of dirt and humidity.

- ▶ To observe degree of protection IP65 / IP67, screw the transparent cap in all the way.

→ Close the device (assembly tool: 674078⁸⁾).

MANUAL operating status (DIP switch 4 set to ON):

Key	Function
1	Aerate ⁹⁾ (manually open / close the actuator) ¹⁰⁾
2	Deaerate ⁹⁾ (manually open / close the actuator) ¹⁰⁾

Table 7: Configuration of the keys for MANUAL operating status

AUTOMATIC operating status (DIP switch 4 set to OFF):

Key	Function
1	Press for 5 s to start the X.TUNE function
2	-

Table 8: Configuration of the keys for AUTOMATIC operating status

⁸⁾ The assembly tool (674078) is available from your Bürkert sales office.

⁹⁾ No function if the binary input was activated with the "Manual/Auto change-over" via the communications software.

¹⁰⁾ depending on the operating principle of the actuator.

7.4 Function of the DIP switches

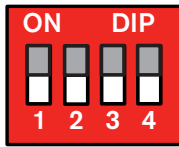

NOTE!

Breakage of the pneumatic connection pieces due to rotational impact.

- ▶ When unscrewing and screwing in the transparent cap, do not hold the actuator of the process valve but the connection housing.

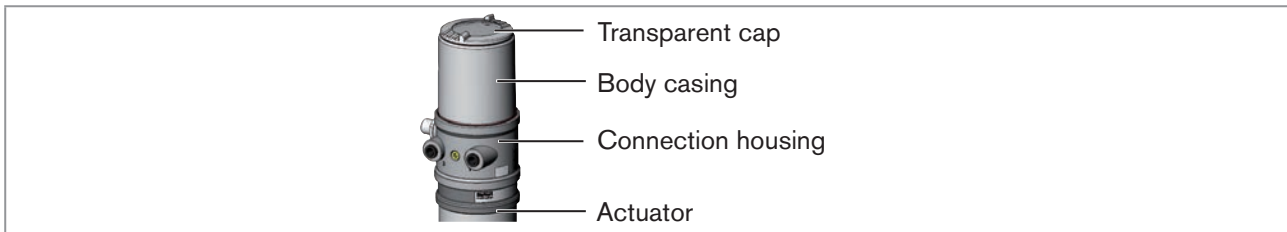

Figure 14: Open positioner

→ To operate the DIP switches, unscrew the transparent cap.

NOTE!

Damage or malfunction due to penetration of dirt and humidity.

- ▶ To observe degree of protection IP65 / IP67, screw the transparent cap in all the way.

→ Close the device (assembly tool: 674078¹¹⁾).

¹¹⁾ The assembly tool (674078) is available from your Bürkert sales office.

DIP Switches	Position	Function
1	ON	Reversal of the effective direction of the set-point value (<i>DIR.CMD</i>) (set-point value 20 – 4 mA corresponds to position 0 – 100 %), descending
	OFF	Normal effective direction of the set-point value (set-point value 4 – 20 mA corresponds to position 0 – 100 %), ascending
2	ON	Sealing function active. The valve completely closes below 2 % ¹²⁾ and opens above 98 % of the set-point value (<i>CUTOFF</i>)
	OFF	No sealing function
3	ON	Correction characteristic for adjustment of the operating characteristic (linearization of the process characteristic <i>CHARACT</i>) ¹³⁾
	OFF	Linear characteristic
4	ON	Operating status MANUAL (BY HAND)
	OFF	Operating status AUTOMATIC (AUTO)

Table 9: DIP Switches

**Information about the communications software:**

The switching position of the DIP switch has priority over the settings via the communications software.

If the values of the sealing function (*CUTOFF*) or the correction characteristic (*CHARACT*) are changed via the communications software, the corresponding function must be active (DIP switches set to ON).

The effective direction of the set-point value (*DIR.CMD*) can be changed via the DIP switches **only**.

If the correction characteristic (*CHARACT*) is not changed via the communications software, a linear characteristic is saved when DIP switch 3 is set to ON.



A detailed description of the functions can be found in the chapter entitled "[12.1 Basic functions](#)".

¹²⁾ Factory setting, can be changed via communications software.

¹³⁾ The characteristic type can be changed via communications software

7.5 Display of the LEDs

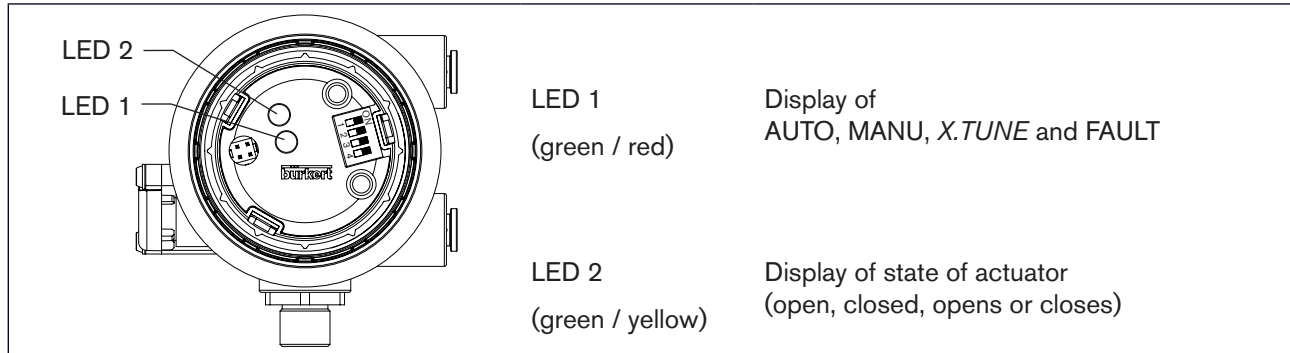

Figure 15: LED display

LED 1 (green / red)

LED States		Display
green	red	
on	off	Acceleration phase when Power ON
flashes slowly	off	Operating status AUTO (AUTOMATIC)
flashing alternating	flashing	MANUAL operating status
flashes quickly	off	X.TUNE function
off	on	ERROR (see chapter "7.6 Error messages")
flashing slow	flashing	AUTO operating status for sensor break detection

Table 10: Display LED 1

LED 2 (green / yellow)

LED States		Display
green	yellow	
on	off	Actuator closed
off	on	Actuator open
flashes slowly	off	Remaining control deviation (actual value > set-point value)
off	flashes slowly	Remaining control deviation (actual value < set-point value)
flashes quickly	off	Closing in MANUAL operating status
off	flashes quickly	Opening in MANUAL operating status

Table 11: Display LED 2

7.6 Error messages

7.6.1 Error messages in MANUAL and AUTOMATIC operating statuses

Display	Cause of fault	Remedial action
LED 1 (red) on	Checksum error in data memory → Data memory defective → The device automatically switches to an older (possibly not current) data record.	Not possible, device defective

Table 12: Error messages in the operating statuses

7.6.2 Error messages while the X.TUNE function is running

Display	Cause of fault	Remedial action
LED 1 (red) on	No compressed air connected	Connect compressed air
	Compressed air failure while the X.TUNE function was running	Check compressed air supply
	Actuator or control system deaeration side leaking	Not possible, device defective
	Control system aeration side leaking	Not possible, device defective

Table 13: Error messages for the X.TUNE function

8 INSTALLATION

8.1 Safety instructions



DANGER!

Risk of injury from high pressure in the equipment/device.

- ▶ Before working on equipment or device, switch off the pressure and deaerate/drain lines.

Risk of electric shock.

- ▶ Before working on equipment or device, switch off the power supply and secure to prevent reactivation.
- ▶ Observe applicable accident prevention and safety regulations for electrical equipment.



WARNING!

Risk of injury from improper installation.

- ▶ Installation may be carried out by authorised technicians only and with the appropriate tools.

Risk of injury from unintentional activation of the system and an uncontrolled restart.

- ▶ Secure system from unintentional activation.
- ▶ Following assembly, ensure a controlled restart.

8.2 Installation of the positioner Type 8696 to process valves of series 2103, 2300 and 2301

NOTE!

When mounting on process valves with a welded body, follow the installation instructions in the operating instructions for the process valve.

Procedure:

1. Install switch spindle

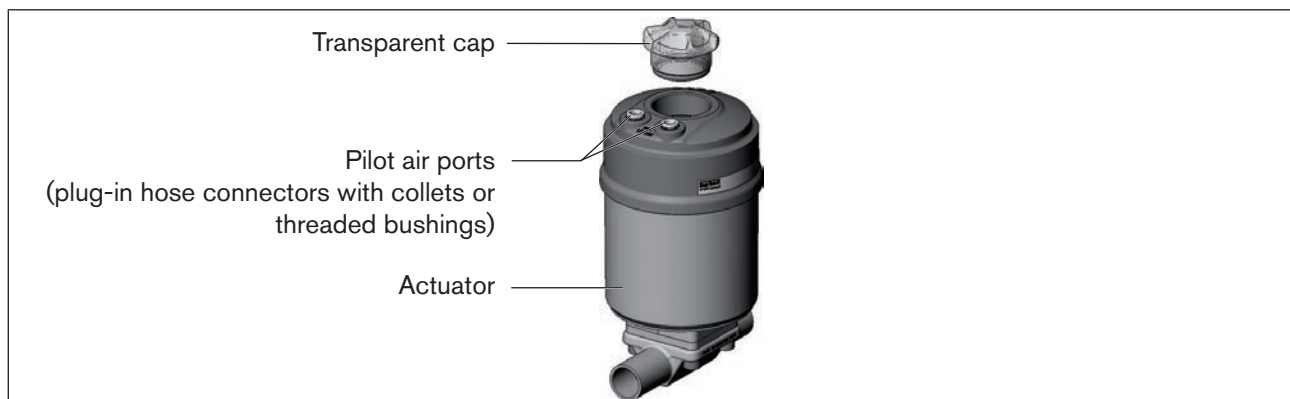

Figure 16: Installation of positioner, series 2103, 2300 and 2301

→ Unscrew the transparent cap on the actuator and unscrew the position display (yellow cap) on the spindle extension (if present).

→ For version with plug-in hose connector, remove the collets (white nozzles) from both pilot air ports (if present).

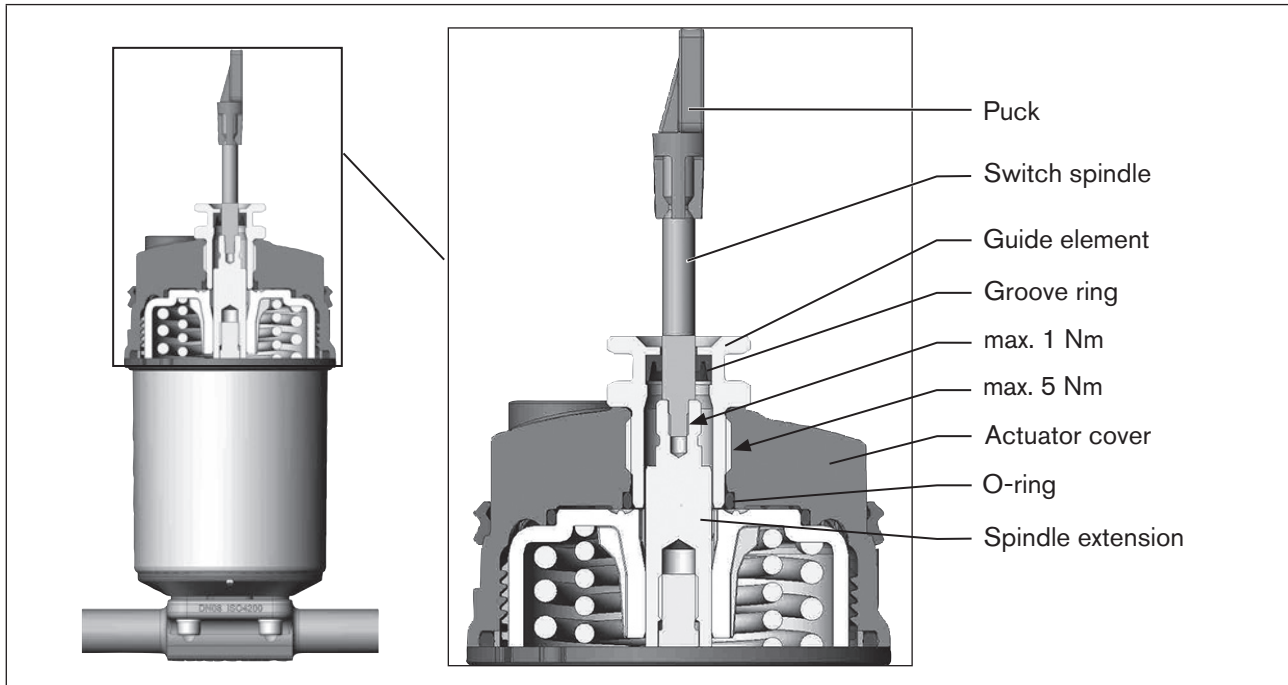

Figure 17: Installing the switch spindle, series 2103, 2300 and 2301

NOTE!

Improper installation may damage the groove ring in the guide element.

The groove ring is already pre-assembled in the guide element and must be “locked into position” in the undercut.

- ▶ When installing the switch spindle, do not damage the groove ring.

→ Push the switch spindle through the guide element.

NOTE!

Screw locking paint may contaminate the groove ring.

- ▶ Do not apply any screw locking paint to the switch spindle.

→ To secure the switch spindle, apply some screw locking paint (Loctite 290) in the tapped bore of the spindle extension in the actuator.

→ Check that the O-ring is correctly positioned.

→ Screw the guide element to the actuator cover (maximum torque: 5 Nm).

→ Screw switch spindle onto the spindle extension. To do this, there is a slot on the upper side (maximum torque: 1 Nm).

→ Push puck onto the switch spindle and lock into position.

2. Install sealing rings

- Pull the form seal onto the actuator cover (smaller diameter points upwards).
- Check that the O-rings are correctly positioned in the pilot air ports.



When the positioner is being installed, the collets of the pilot air ports must not be fitted to the actuator.

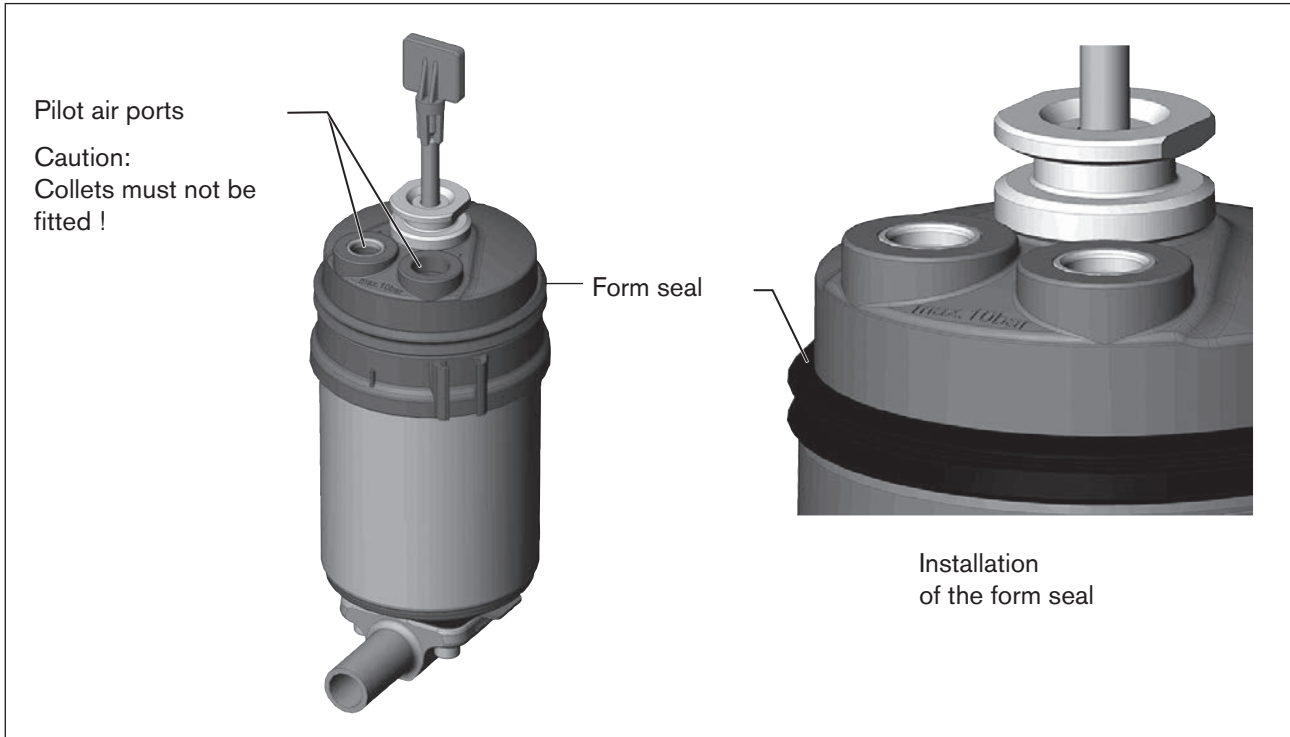

Figure 18: Installation of the sealing rings

3. Install positioner

- Align the puck and the positioner until
 1. the puck can be inserted into the guide rail of the positioner and
 2. the connection pieces of the positioner can be inserted into the pilot air ports of the actuator (see also "Figure 20").

NOTE!

Damaged printed circuit board or malfunction.

- ▶ Ensure that the puck is situated flat on the guide rail.

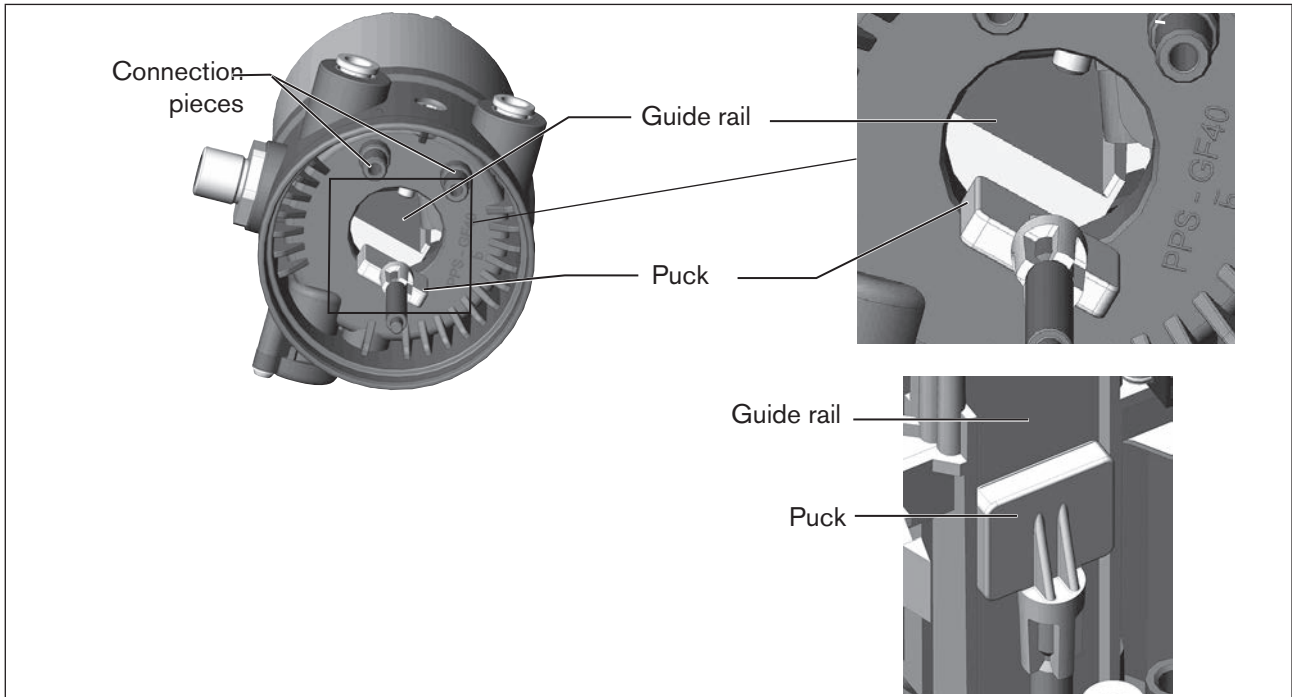

Figure 19: *Aligning the puck*

→ Push the positioner, without turning it, onto the actuator until no gap is visible on the form seal.

NOTE!

Too high torque when screwing in the fastening screw does not ensure degree of protection IP65 / IP67.

▶ The fastening screws may be tightened to a maximum torque of 1.5 Nm only.

→ Attach the positioner to the actuator using the two side fastening screws. In doing so, tighten the screws only hand-tight (max. torque: 1.5 Nm).

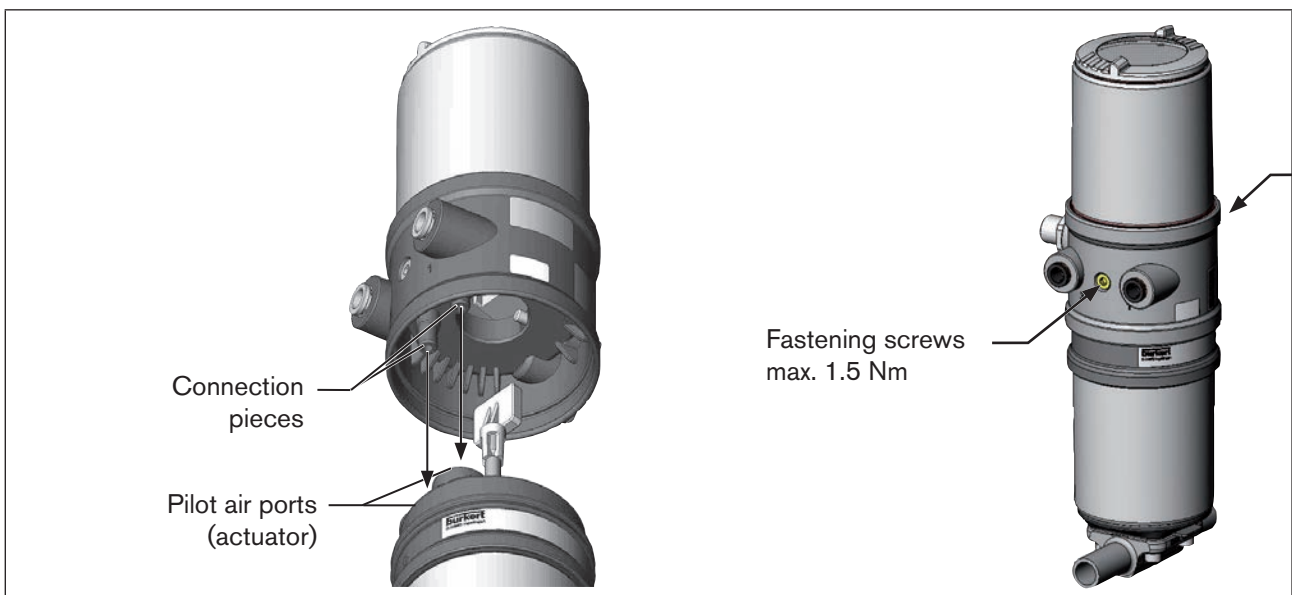

Figure 20: *Installation of the positioner*

8.3 Rotating the actuator module for process valves belonging to series 2300 and 2301

! The actuator module (positioner and actuator) can be rotated for straight seat valves and angle seat valves belonging to series 2300 and 2301 only.

The position of the connections can be aligned steplessly by rotating the actuator module (positioner and actuator) through 360°.

! Only the entire actuator module can be rotated. The positioner cannot be rotated contrary to the actuator. The process valve must be in the open position for alignment of the actuator module.

! **DANGER!**

Risk of injury from high pressure in the equipment/device.

- ▶ Before working on equipment or device, switch off the pressure and deaerate/drain lines.

Procedure:

- Clamp valve body in a holding device (only required if the process valve has not yet been installed).
- Control function A: Open process valve.

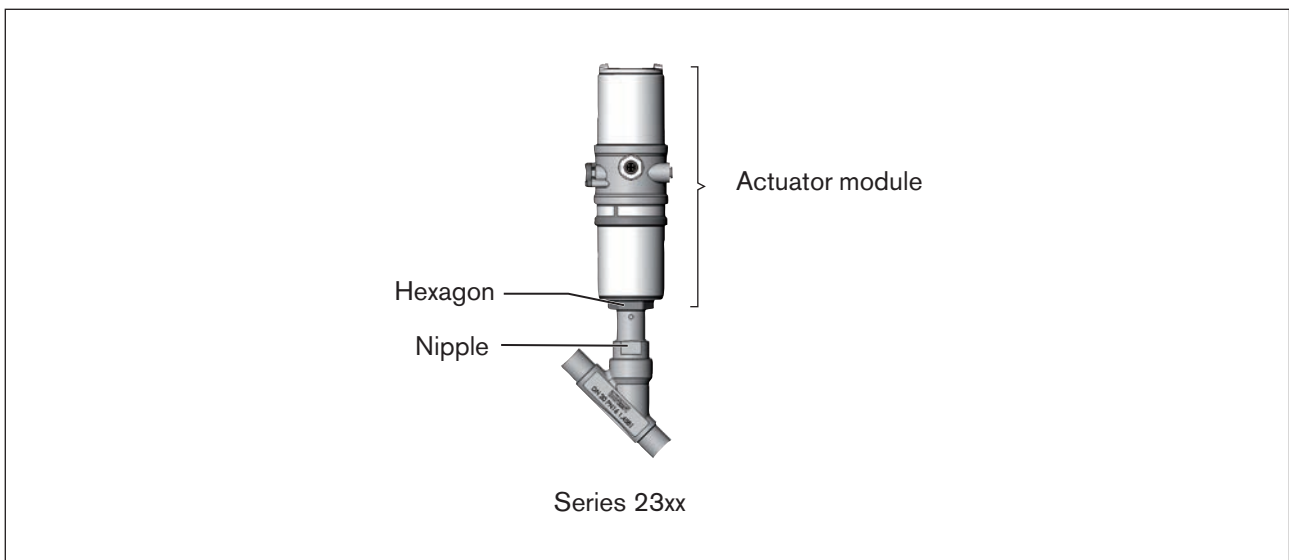

Figure 21: Rotating the actuator module

→ Using a suitable open-end wrench, counter the wrench flat on the pipe.

→ Place suitable open-end wrench on the hexagon of the actuator.

**WARNING!**

Risk of injury from discharge of medium and pressure.

If the direction of rotation is wrong, the body interface may become detached.

▶ Rotate the actuator module counter-clockwise only (see "Figure 22").

→ Rotate counter-clockwise (as seen from below) to bring the actuator module into the required position.

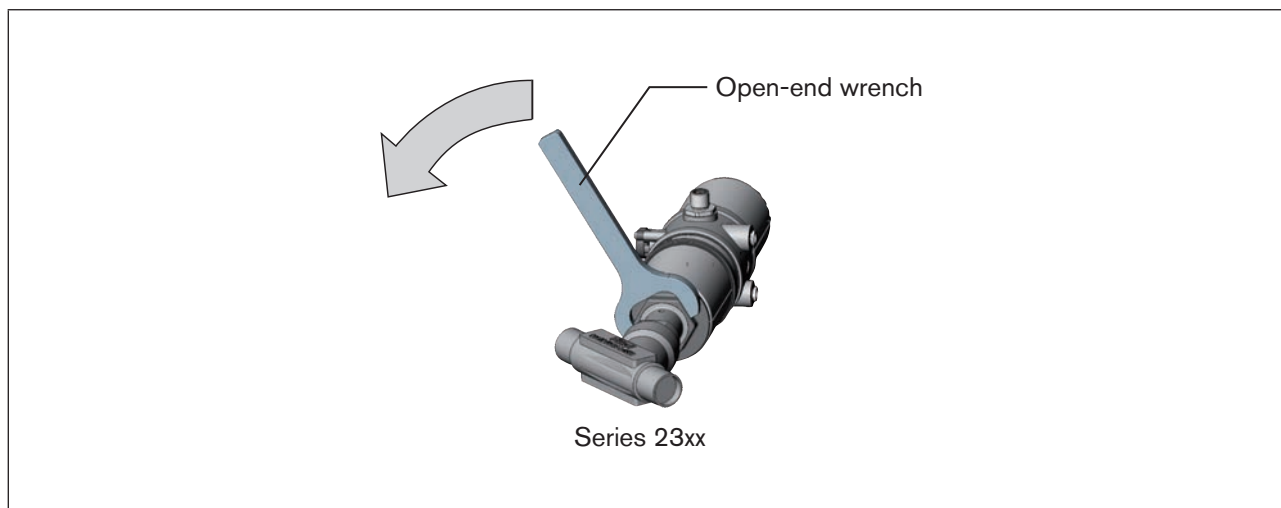

Figure 22: Rotating open-end wrench

9 PNEUMATIC INSTALLATION

DANGER!

Risk of injury from high pressure in the equipment/device.

- ▶ Before working on equipment or device, switch off the pressure and deaerate/drain lines.

WARNING!

Risk of injury from improper installation.

- ▶ Installation may be carried out by authorised technicians only and with the appropriate tools.

Risk of injury from unintentional activation of the system and an uncontrolled restart.

- ▶ Secure system from unintentional activation.
- ▶ Following installation, ensure a controlled restart.

Procedure:

- Connect the control medium to the pilot air port (1)
(3 – 7 bar; instrument air, free of oil, water and dust).
- Attach the exhaust airline or a silencer to the exhaust air port (3).



Important information for the problem-free functioning of the device:

- ▶ The installation must not cause back pressure to build up.
- ▶ Select a hose for the connection with an adequate cross-section.
- ▶ The exhaust air line must be designed in such a way that no water or other liquid can get into the device through the exhaust air port.

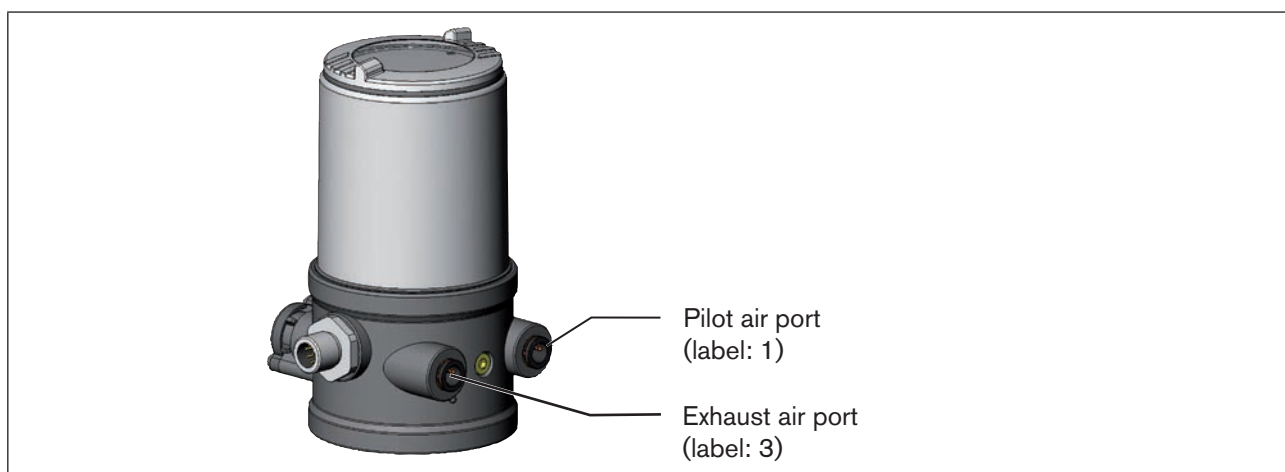

Figure 23: Pneumatic connection



Caution: (Exhaust air concept):

In compliance with degree of protection IP67, an exhaust air line must be installed in the dry area.

Keep the adjacent supply pressure **always** at least 0.5 – 1 bar above the pressure which is required to move the actuator to its end position. This ensures that the control behavior is not extremely negatively affected in the upper stroke range on account of too little pressure difference.

During operation keep the fluctuations of the pressure supply as low as possible (max. $\pm 10\%$). If fluctuations are greater, the control parameters measured with the *X.TUNE* function are not optimum.

10 ELECTRICAL INSTALLATION 24 V DC

All electrical inputs and outputs of the device are not galvanically isolated from the supply voltage.

The kind of connection is used for the electrical bonding of the positioner:

- **Multipole**
with circular plug-in connector M12 x 1, 8-pole

10.1 Safety instructions



DANGER!

Risk of electric shock.

- ▶ Before working on equipment or device, switch off the power supply and secure to prevent reactivation.
- ▶ Observe applicable accident prevention and safety regulations for electrical equipment.



WARNING!

Risk of injury from improper installation.

- ▶ Installation may be carried out by authorized technicians only and with the appropriate tools.

Risk of injury from unintentional activation of the system and an uncontrolled restart.

- ▶ Secure system from unintentional activation.
- ▶ Following installation, ensure a controlled restart.

Minimum temperature rating of the cable to be connected to the field wiring terminals: 75 °C

10.2 Electrical installation with circular plug-in connector

DANGER!

Risk of electric shock.

- ▶ Before working on equipment or device, switch off the power supply and secure to prevent reactivation.
- ▶ Observe applicable accident prevention and safety regulations for electrical equipment.

10.2.1 Designation of the contacts Type 8696

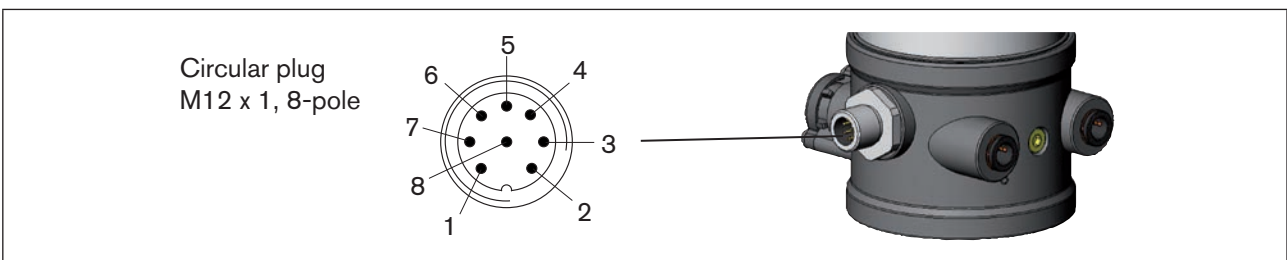

Figure 24: Circular plug M12 x 1, 8-pole

10.2.2 Connection of the positioner Type 8696

→ Connect the pins according to the model (options) of the positioner.

Input signals of the control center (e.g. PLC) - circular plug M12 x 1, 8-pole

Pin	Wire color ¹⁴⁾	Configuration	external circuit / signal level
1	white	Set-point value + (0/4 – 20 mA)	1 ○ — + (0/4 – 20 mA)
2	brown	Set-point value GND	2 ○ — GND
5	grey	Binary input +	5 ○ — +
6	pink	Binary input -	6 ○ — GND

Table 14: Pin assignment - input signals of the control center - circular plug M12 x 1, 8-pole

Output signals to the control center (e.g. PLC) - circular plug M12 x 1, 8-pole (required for analogue output option only)

Pin	Wire color ¹³⁾	Configuration	external circuit / signal level
8	red	Analogue position feedback +	8 ○ — → + (0/4 – 20 mA)
7	blue	Analogue position feedback GND	7 ○ — → GND

Table 15: Pin assignment - output signals of the control center - circular plug M12 x 1, 8-pole

¹⁴⁾ The indicated colors refer to the connecting cable available as an accessory (919061)

Supply voltage (circular plug M12 x 1, 8-pole)

Pin	Wire color ¹⁵⁾	Configuration	External circuit
4	yellow	+ 24 V	 <p>24 V DC ± 10 % max. residual ripple 10 %</p>
3	green	GND	

Table 16: Pin assignment - supply voltage (circular plug M12 x 1, 8-pole)

¹⁵⁾ The indicated colors refer to the connecting cable available as an accessory (919061)

When the supply voltage is applied, the positioner is operating.

→ Make the required basic settings and actuate the automatic adjustment of the positioner, as described in the chapter entitled [“11 Start-up”](#).

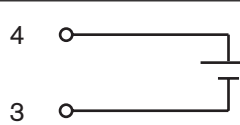
11 START-UP

11.1 Safety instructions

DANGER!

Risk of electric shock.

- ▶ Before working on equipment or device, switch off the power supply and secure to prevent reactivation.
- ▶ Observe applicable accident prevention and safety regulations for electrical equipment.

WARNING!

Risk of injury from improper operation.

Improper operation may result in injuries as well as damage to the device and the area around it.

- ▶ Before start-up, ensure that the operating personnel are familiar with and completely understand the contents of the operating instructions.
- ▶ Observe the safety instructions and intended use.
- ▶ Only adequately trained personnel may operate the equipment/the device.

11.2 Specifying the standard settings

The basic settings of the positioner are implemented at the factory.

 To adjust the positioner to local conditions, the *X.TUNE* function must be run following installation.

11.2.1 Running the automatic adjustment *X.TUNE*

WARNING!

While the *X.TUNE* function is running, the valve automatically moves from its current position.

- ▶ Never run *X.TUNE* while a process is running.
- ▶ Take appropriate measures to prevent the equipment from being accidentally actuated.

NOTE!

Avoid maladjustment of the controller due to an incorrect pilot pressure or applied operating medium pressure.

- ▶ Run *X.TUNE* **whenever** the pilot pressure (= pneumatic auxiliary energy) is available during subsequent operation.
- ▶ Run the *X.TUNE* function preferably **without** operating medium pressure to exclude interference caused by flow forces.

 To run *X.TUNE*, the positioner must be in the AUTOMATIC operating status (DIP switch 4 = OFF).

NOTE!

Breakage of the pneumatic connection pieces due to rotational impact.

- ▶ When unscrewing and screwing in the transparent cap, do not hold the actuator of the process valve but the connection housing.

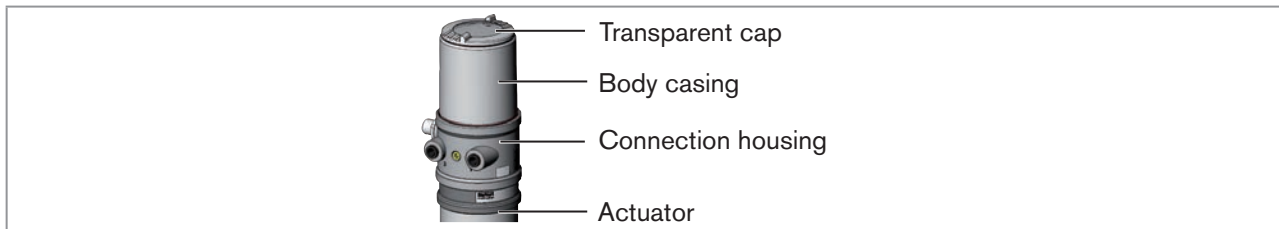

Figure 25: Open positioner

→ Screw off the transparent cap of the positioner to operate the keys and DIP switches.

→ Start the *X.TUNE* by pressing key 1¹⁶⁾ for 5 s.

While the *X.TUNE* is running, LED 1 flashes quickly (green).

When the automatic adjustment is complete, LED 1 flashes slowly (green)¹⁷⁾.

The changes are automatically transferred to the memory (EEPROM) provided the *X.TUNE* function is successful.

NOTE!

Damage or malfunction due to penetration of dirt and humidity.

- ▶ To observe degree of protection IP65 / IP67, screw the transparent cap in all the way.

→ Close the device (assembly tool: 674078¹⁸⁾).

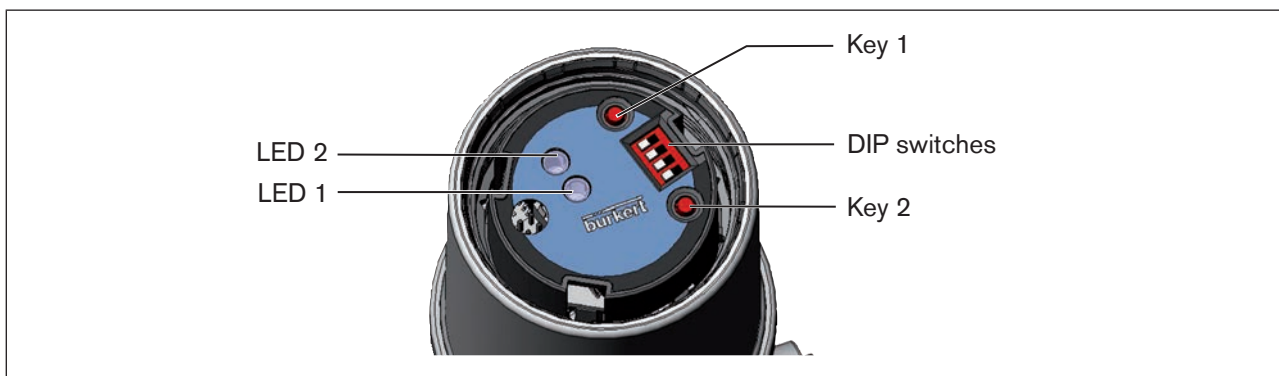

Figure 26: Starting *X.TUNE*

¹⁶⁾ The *X.TUNE* can also be started via communications software.

¹⁷⁾ if a fault occurs, LED 1 is lit red.

¹⁸⁾ The assembly tool (674078) is available from your Bürkert sales office

12 OPERATION AND FUNCTION

The positioner Type 8696 has different basic and additional functions which can be configured and parameterized via the DIP switches or the communications software.

12.1 Basic functions

The following basic functions can be activated via the DIP switches (*CUTOFF* and *CHARACT*) or changed (*DIR.CMD*).

Function	Description	DIP Switches	OFF	ON
<i>DIR.CMD</i>	Effective direction between input signal and set-point position	1	Rise	Fall
<i>CUTOFF</i>	Sealing function for positioner	2	Sealing function off	Sealing function on
<i>CHARACT</i>	Selection of the Transfer Characteristic between Input Signal and Stroke (Correction Characteristic)	3	Linear characteristic	Correction characteristic

Table 17: Basic functions of DIP switches

NOTE!

Breakage of the pneumatic connection pieces due to rotational impact.

- ▶ When unscrewing and screwing in the transparent cap, do not hold the actuator of the process valve but the connection housing.

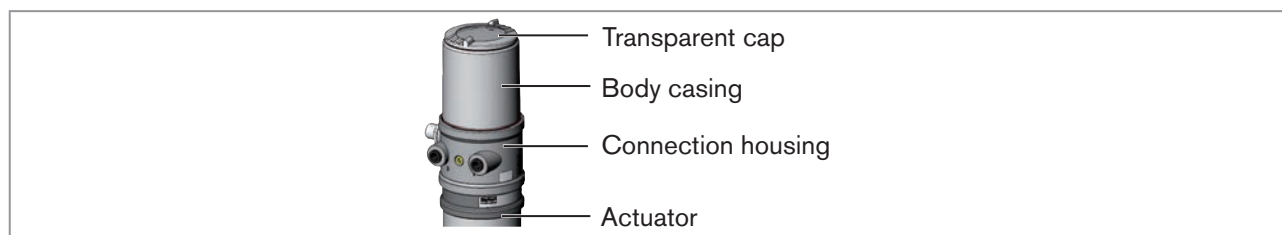

Figure 27: Open positioner

→ Screw off the transparent cap of the positioner to operate the DIP switches.

NOTE!

Damage or malfunction due to penetration of dirt and humidity.

- ▶ To observe degree of protection IP65 / IP67, screw the transparent cap in all the way.

→ Close the device (assembly tool: 674078¹⁹⁾).

¹⁹⁾ The assembly tool (674078) is available from your Bürkert sales office

The following basic function can be changed via the communications software only.

Function	Description	Factory setting
<i>INPUT</i>	Entry of the standard signal input for the set-point value	4 – 20 mA
<i>RESET</i>	Reset to factory settings	
<i>X.TUNE</i>	Automatic adjustment of the positioner to the relevant operating conditions	

Table 18: Basic function of communications software

The *INPUT*, *CUTOFF* and *CHARACT* functions can be parameterized via the communications software.

12.1.1 *DIR.CMD* - Effective direction of the positioner set-point value

You can use this function to adjust the effective direction between the input signal (*INPUT*) and the nominal position of the actuator.

Factory setting: DIP switch set to OFF (ascending)

DIP Switches	Position	Function
1	ON	Reversal of the effective direction of the set-point value (<i>DIR.CMD</i>) (set-point value 20 – 4 mA corresponds to position 0 – 100 %), fall
	OFF	Normal effective direction of the set-point value (set-point value 4 – 20 mA corresponds to position 0 – 100 %), rise

Table 19: DIP switch 1



The effective direction (*DIR.CMD*) can **only** be changed via DIP switch 1 in the positioner.

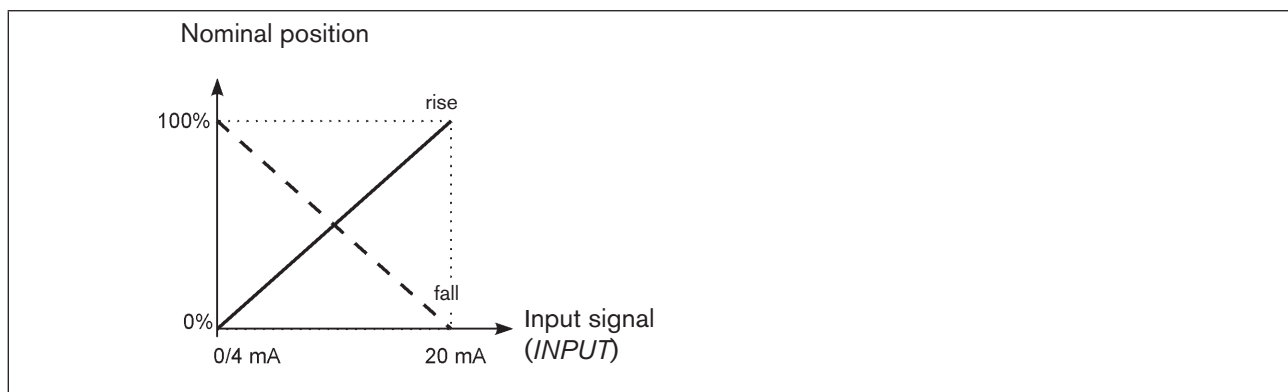

Figure 28: *DIR.CMD* graph

12.1.2 CUTOFF - Sealing function for the positioner

This function causes the valve to be sealed outside the control range.

Control mode resumes at a hysteresis of 1%.

Factory setting: DIP switch 2 set to OFF (no sealing function)

DIP Switches	Position	Function
2	ON	Sealing function active. The valve completely closes below 2 % ²⁰⁾ and opens above 98 % of the set-point value (<i>CUTOFF</i>)
	OFF	No sealing function

Table 20: DIP switch 2

The communications software can be used to change the limits for the position set-point value as a percentage.



The switching position of the DIP switches in the positioner has priority over the communications software, i.e. settings of the sealing function (*CUTOFF*) which are modified via the communications software are only active if DIP switch 2 in the positioner is set to ON.

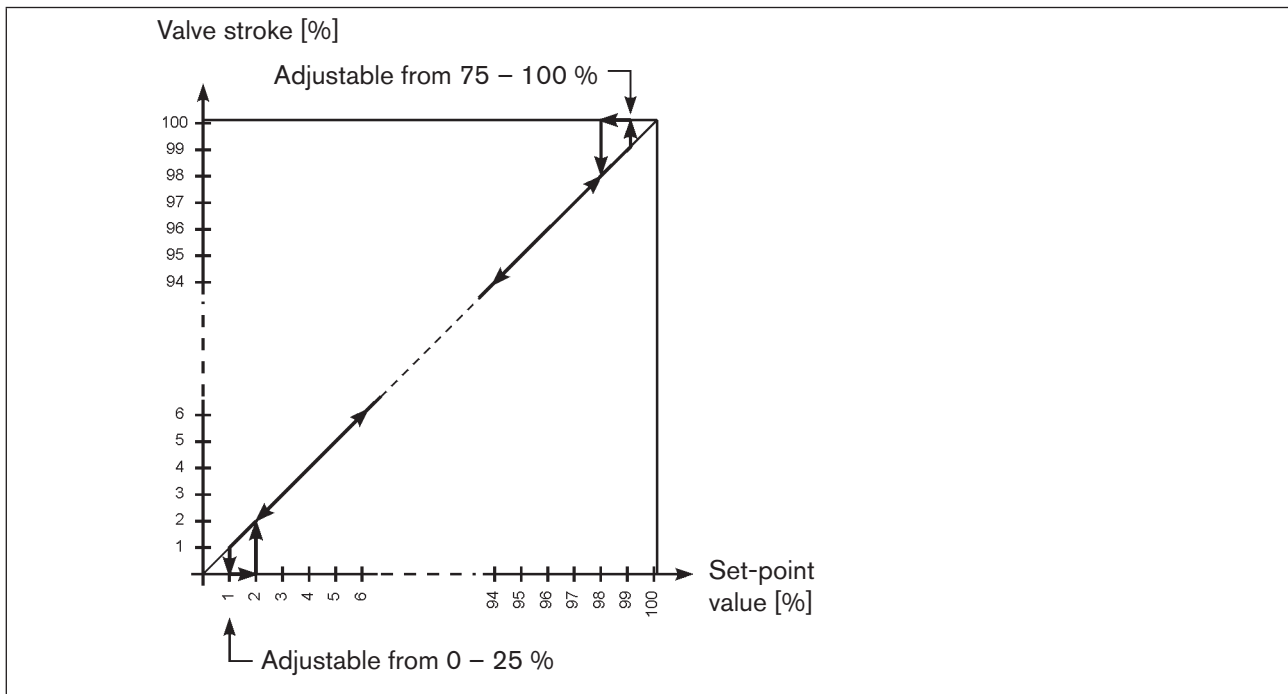

Figure 29: CUTOFF graph

²⁰⁾ Factory setting can be changed via communications software.

12.1.3 CHARACT - Select the transfer characteristic between input signal (position set-point value) and stroke

Characteristic (customer-specific characteristic)

This function can be used to activate a transfer characteristic with respect to set-point value (set-point position) and valve stroke for correction of the flow-rate or operating characteristic.



The transfer characteristic can be changed via the communications software only.

Factory setting: DIP switch 3 set to OFF (linear)

DIP Switches	Position	Function
3	ON	Correction characteristic for adjustment of the operating characteristic (linearization of the process characteristic <i>CHARACT</i>) ²¹⁾
	OFF	Linear characteristic

Table 21: DIP switch 3



The switching position of the DIP switches in the positioner has priority over the communications software, i.e. settings of the correction characteristic (*CHARACT*) which are modified via the communications software are only active if DIP switch 3 in the positioner is set to ON.

Characteristics which can be selected via the communications software:

Characteristic	Description
linear	Linear characteristic
1 : 25	Equal percentage characteristic 1 : 25
1 : 33	Equal percentage characteristic 1 : 33
1 : 50	Equal percentage characteristic 1 : 50
25 : 1	Inversely equal percentage characteristic 25 : 1
33 : 1	Inversely equal percentage characteristic 33 : 1
55 : 1	Inversely equal percentage characteristic 55 : 1
FREE	User-defined characteristic, freely programmable via nodes

Table 22: Selection of characteristics

²¹⁾ The characteristic type can be changed via the communications software only.

The flow characteristic $k_v = f(s)$ indicates the flow-rate of a valve, expressed by the value k_v as a function of the stroke s of the actuator spindle. It is determined by the design of the valve seat and the seat seal. In general two types of flow characteristics are implemented, the linear and the equal percentage.

In the case of linear characteristics, equal k_v value changes dk_v are assigned to equal stroke changes ds .

$$(dk_v = n_{lin} \cdot ds).$$

In the case of an equal percentage characteristic, an equal percentage change of the k_v value corresponds to a stroke change ds .

$$(dk_v/k_v = n_{eqprct} \cdot ds).$$

The operating characteristic $Q = f(s)$ specifies the correlation between the volumetric flow Q in the installed valve and the stroke s . This characteristic has the properties of the pipelines, pumps and consumers. It therefore exhibits a form which differs from the flow characteristic.

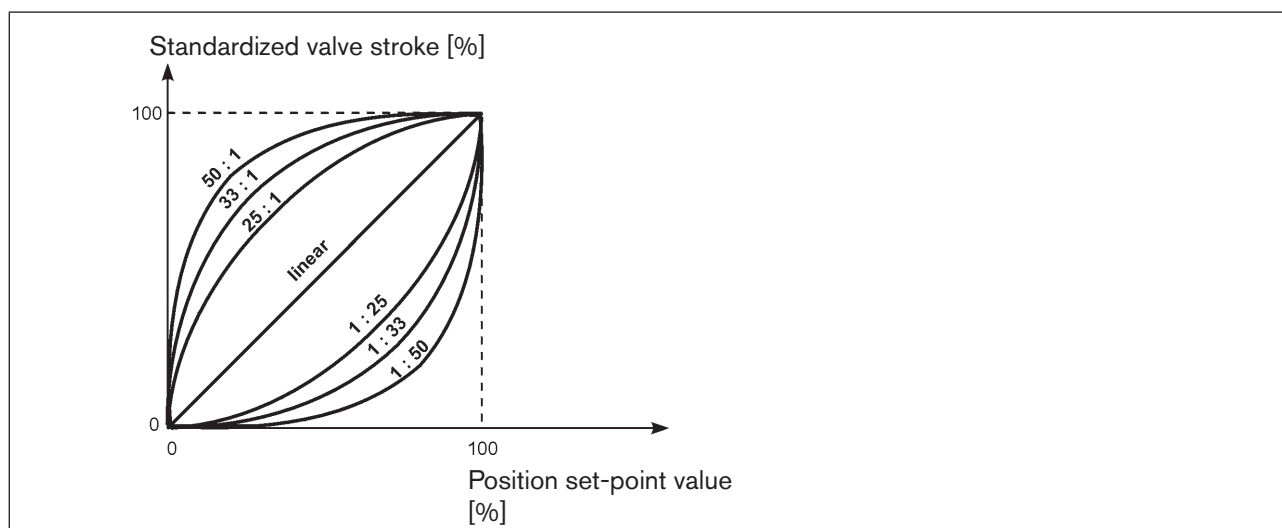

Fig. 30: Characteristic

In the case of control tasks for closed-loop control systems it is usually particular demands which are placed on the course of the operating characteristic, e.g. linearity. For this reason it is occasionally necessary to correct the course of the operating characteristic in a suitable way. For this purpose the positioner features a transfer element which implements different characteristics. These are used to correct the operating characteristic.

Equal percentage characteristics 1:25, 1:33, 1:50, 25:1, 33:1, and 50:1 as well as a linear characteristic can be set. A characteristic can be freely programmed using nodes.

Entering the freely programmable characteristic

The characteristic is defined by 21 nodes distributed uniformly over the position set-point values ranging from 0 – 100 %. They are spaced at intervals of 5 %. A freely selectable stroke (adjustment range 0 – 100 %) is assigned to each node. The difference between the stroke values of two adjacent nodes must not be greater than 20%.

Example of a programmed characteristic

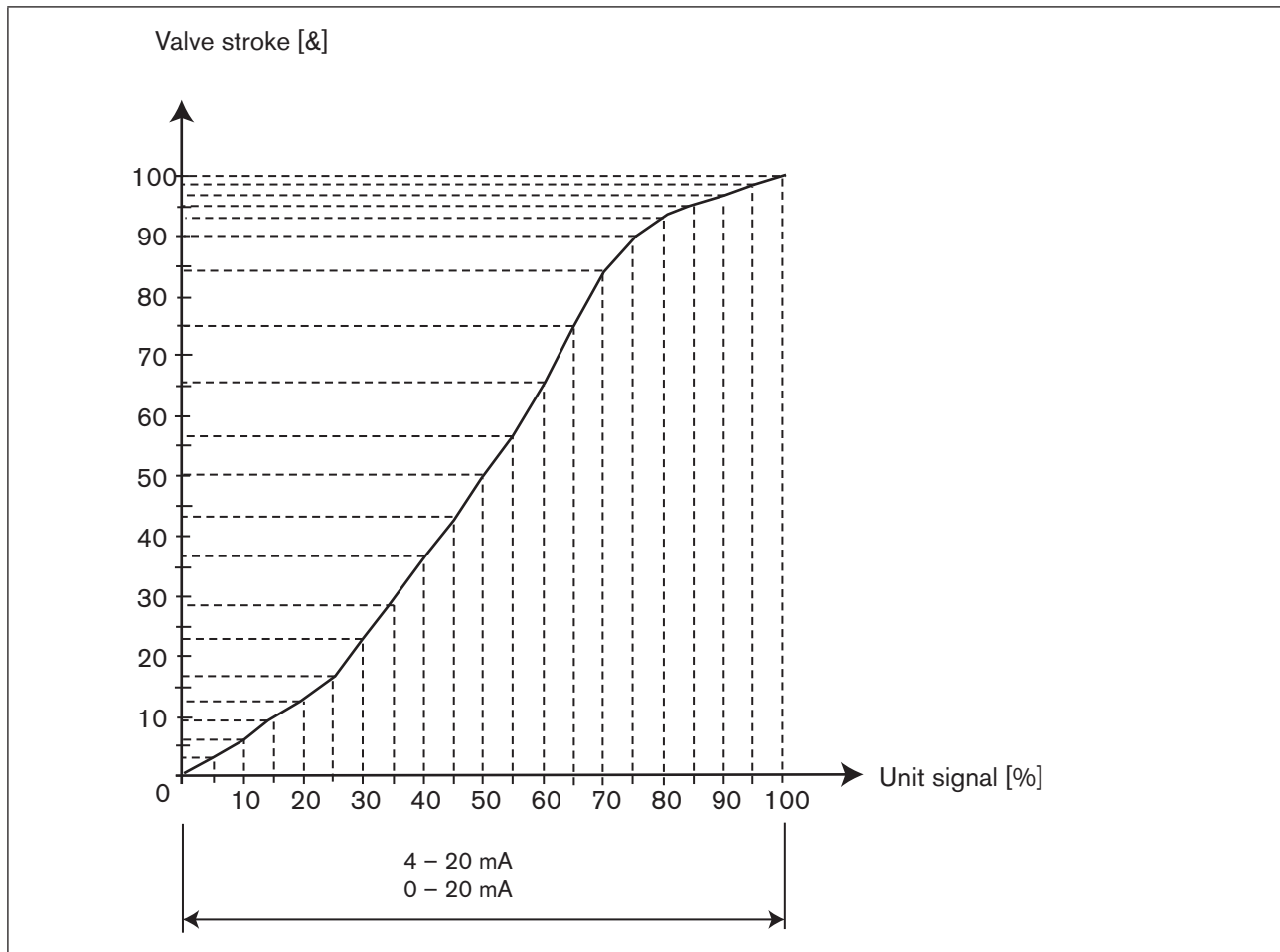

Fig. 31: Example of a programmed characteristic

12.1.4 INPUT - Enter the input signal

Under this menu option, enter the unit signal used for the set-point value.

Factory setting: 4 – 20 mA

12.1.5 **RESET -** **Reset to factory settings**

This function can be used to reset the positioner to the factory settings.

12.1.6 **X.TUNE -** **Automatic adjustment of the positioner to the relevant operating conditions**



The *X.TUNE* function must be run for a function check of the positioner to adjust to specific local features.



WARNING!

While the *X.TUNE* function is running, the valve automatically moves from its current position.

- ▶ Never run *X.TUNE* while a process is running.
- ▶ Take appropriate measures to prevent the system / positioner from being unintentionally actuated.

NOTE!

Avoid maladjustment of the controller due to an incorrect compressed air supply or applied operating medium pressure.

- ▶ Run *X.TUNE* **whenever** the compressed air supply (= pneumatic auxiliary energy) is available during subsequent operation.
- ▶ Run the *X.TUNE* function preferably **without** operating medium pressure to exclude interference caused by flow forces.



To run *X.TUNE*, the positioner must be in the AUTOMATIC operating state (DIP switch 4 = OFF).

→ Set up *TUNE* / *TUNE* Functions.

→ Start *X.TUNE*. To do this, click „Start *X.TUNE*“ ²⁾.

The progress of *X.TUNE* is shown in the communication software:

When the automatic adjustment completes, a message appears.

The changes are automatically transferred to the positioner's memory (EEPROM) after the *X.TUNE* function is successful.

12.2 Auxiliary functions

The following additional functions can be configured and parameterized via the communications software:

Function	Description
<i>DIR.ACTUATOR</i>	Assignment of the aeration status of the actuator chamber to the actual position
<i>SPLITRANGE</i>	Signal split range; input signal as a % for which the valve runs through the entire stroke range
<i>X.LIMIT</i>	Limit the mechanical stroke range
<i>X.TIME</i>	Limit the control speed
<i>X.CONTROL</i>	Parameterize the positioner
<i>SAFE POSITION</i>	Input the safety position
<i>SIGNAL ERROR</i>	Configuration of signal level fault detection
<i>BINARY INPUT</i>	Activation of the binary input
<i>OUTPUT</i>	Configuration of the outputs (only with auxiliary board for analogue feedback signal or binary outputs)

Table 23: Auxiliary functions

12.2.1 *DIR.ACTUATOR* - Effective direction of the actuator

Use this function to set the effective direction between the aeration state of the actuator and the actual position.

Factory setting: rise

Rise: Direct effective direction (deaerated → 0 %; aerated 100 %)

Case: Inverse effective direction (deaerated → 100 %; aerated 0 %)

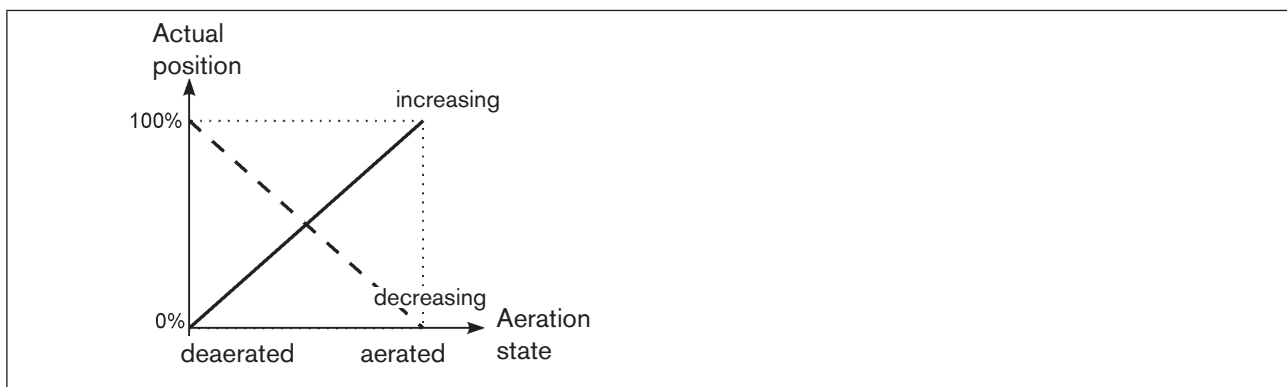

Fig. 32: *DIR.ACTUATOR* graph

12.2.2 *SPLITRANGE* - Signal split range

Minimum and maximum values of the input signal as a % for which the valve runs through the entire stroke range.

Factory setting: Lower signal range split = 0 %; Upper signal range split = 100 %

Lower value split range: Input the minimum value of the input signal as a %
Adjustment range: 0 – 75 %

Upper value split range: Input the maximum value of the input signal as a %
Adjustment range: 25 – 100 %

Use this function to limit the position set-point value range of the positioner by specifying a minimum and a maximum value. This makes it possible to divide a unit signal range that is used (4 – 20 mA, 0 – 20 mA) into several positioners (without or with overlapping). This allows several valves to be used alternately or, in the case of overlapping set-point value ranges, simultaneously as actuators.

To split a unit signal range into two set-point value ranges:

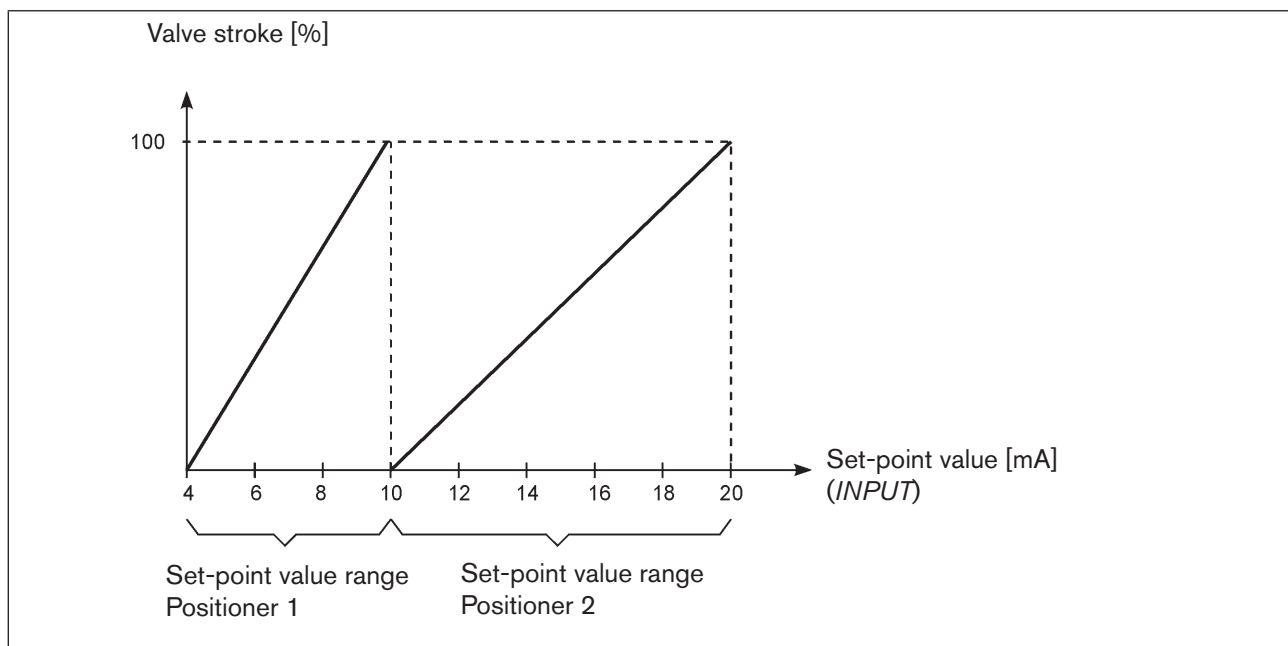

Fig. 33: *SPLTRNG* graph

12.2.3 X.LIMIT - Limiting the mechanical stroke range

This function limits the (physical) stroke to specified % values (lower and upper). In doing so, the stroke range of the limited stroke is set equal to 100 %. If the limited stroke range is left during operation, negative actual positions or actual positions greater than 100 % are shown.

Factory setting: Lower position limit = 0 %, upper position limit = 100 %

Adjustment ranges:

Lower position limit: 0 – 50 % of the entire stroke

Upper position limit: 50 – 100 % of the entire stroke

The minimum distance between the upper and lower stroke limit is 50 %. Therefore if one value is entered with a minimum distance of < 50 % the other value is adjusted automatically.

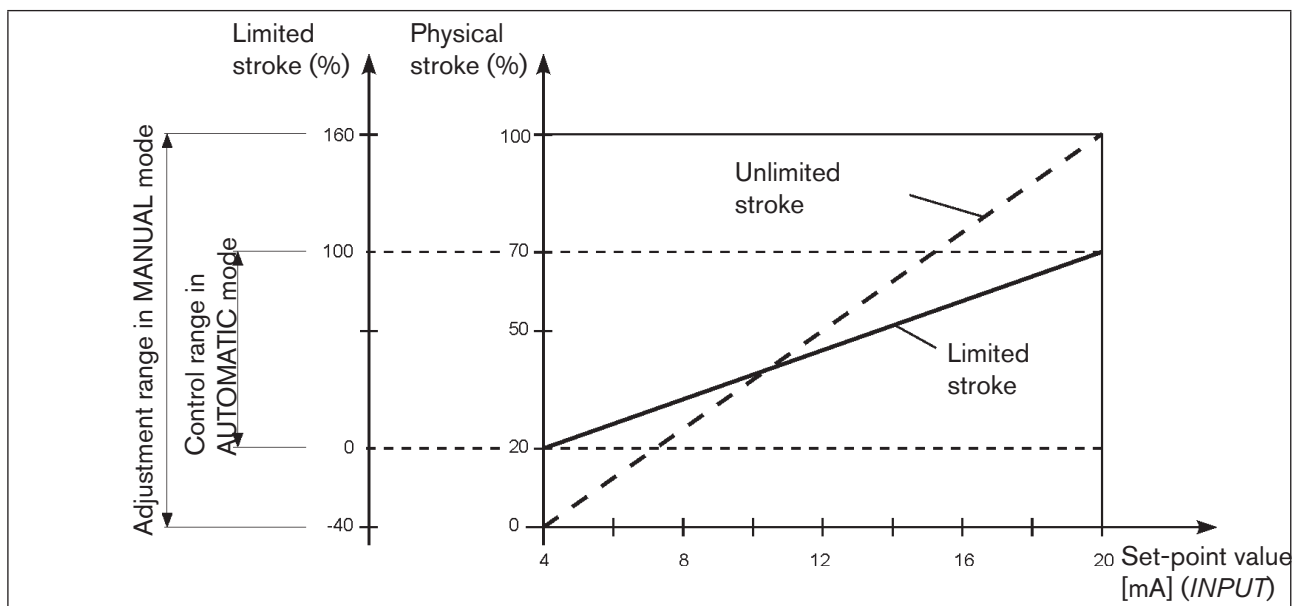

Fig. 34: X.LIMIT graph

12.2.4 X.TIME - Limiting the control speed

Use this function to specify the opening and closing times for the entire stroke and thereby limit control speeds.



When the *X.TUNE* function is running, the minimum opening and closing time for the entire stroke is automatically entered for Open and Close. Therefore, movement can be at maximum speed.

Factory setting: values determined at the factory by the *X.TUNE* function

If the control speed will be limited, values can be input for Open and Close which are between the minimum values determined by the *X.TUNE* and 60 seconds.

Valve timeopen: Opening time for entire stroke (in seconds)
Adjustment range: 1 – 60 seconds

Valve timeclose: Closing time for entire stroke (in seconds)
Adjustment range: 1 – 60 seconds

Effect of limiting the opening speed when there is a jump in the set-point value

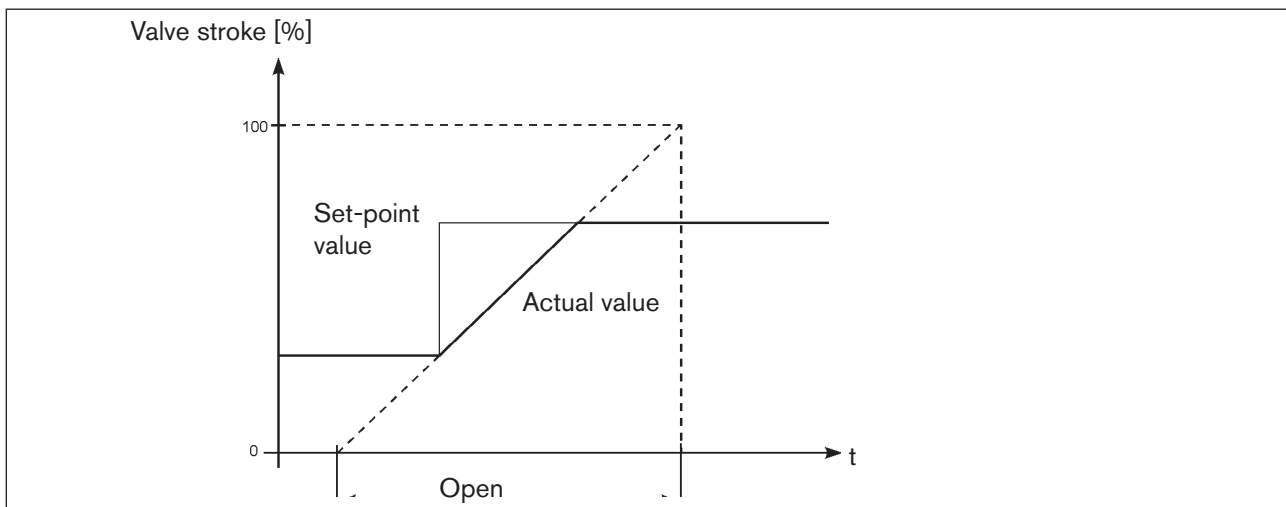

Fig. 35: *X.TIME* graph

12.2.5 X.CONTROL - Parameterization of the positioner

Use this function to set the parameters for the positioner (dead band and amplification factors (kp)).

Deadband: Insensitivity range of the positioner

Entry for the deadband as a % in reference to the scaled stroke range;
i.e. X.LIMIT upper stroke limit - X.LIMIT lower stroke (see auxiliary function X.LIMIT).

This function causes the controller to respond only beginning at a specific control difference. This function saves wear on the solenoid valves in the positioner and the pneumatic actuator.



If the auxiliary function X.CONTROL is in the main menu while X.TUNE (Autotune of the positioner) is running, the deadband is determined automatically depending on the friction behavior of the actuator drive. The value determined in this way is an approximate value. You can re-adjust it manually.

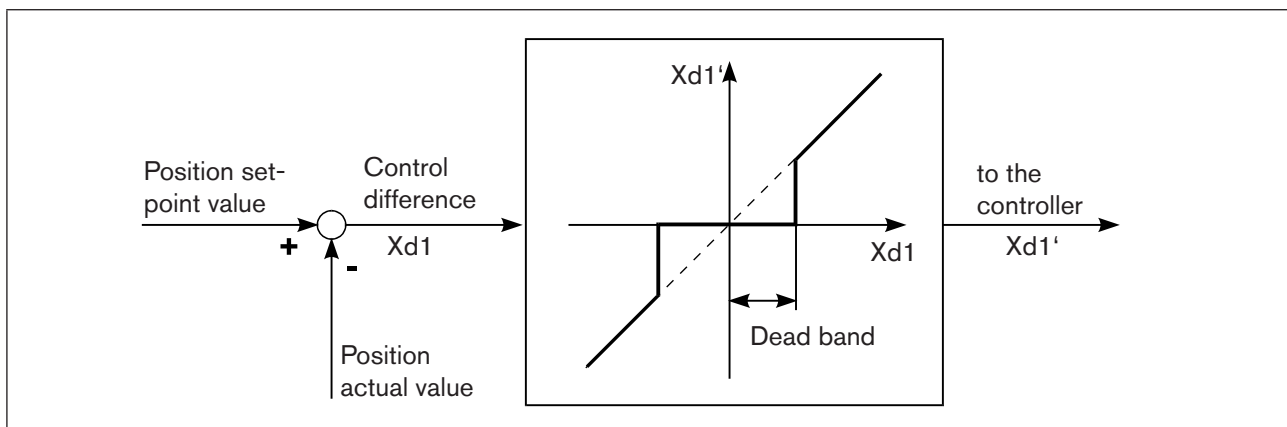

Fig. 36: X.CONTROL graph

Open/close amplification factor: Parameters for the positioner

Open amplification factor: Amplification factor of the positioner (for closing the valve)

Close amplification factor: Amplification factor of the positioner (for opening the valve)

12.2.6 SAFE POSITION - Definition of the safe position

This function specifies the actuator safety position which is approached at defined signals.



The set safety position is only approached if there is a corresponding signal at the binary input (for configuration see BINARY INPUT) or if a signal error occurs (for configuration see SIGNAL ERROR). If the mechanical stroke range is limited with the X.LIMIT function, only safety positions within these limits can be approached. This function is executed in AUTOMATIC mode only.

12.2.7 **SIGNAL ERROR -** **Configuration of signal level fault detection**

The *SIGNAL ERROR* function is used to detect a fault on the input signal.



Fault detection

Fault detection can be selected for a 4 – 20 mA signal only:

Fault if input signal ≤ 3.5 mA (± 0.5 % of final value, hysteresis 0.5 % of final value)

If 0 – 20 mA is selected, sensor break detection cannot be selected.

A signal error is indicated on the device by the red LED for “setpoint error detection” ON.

Safety position for sensor break ON:

The following configurations can occur with “safety position if setpoint error” ON:

Active *SAFE POSITION*

If a fault is detected, the drive moves to the lower *SAFE POSITION* set position.

Inactive *SAFE POSITION*

If a fault is detected, the drive moves to the end position which it would assume in the isolated state.

12.2.8 **BINARY INPUT -** **Activation of the binary input**

This function activates the binary input.

The following settings can be implemented for this:

- Approach the safety position
- Switching over the MANUAL/AUTOMATIC operating mode
- Starting the function *X.TUNE* (valid since software version A.18).

Safety position

Approach the safety position.

Active *SAFE POSITION* function

the drive moves to the lower *SAFE POSITION* set position.

Inactive *SAFE POSITION*

The drive moves to the end position which it would assume in the isolated state.

Switch over the operating state to MANUAL or AUTOMATIC.

Binary input = 0 → AUTOMATIC operating state

Binary input = 1 → MANUAL operating state

If switching over the operating mode is selected, you can no longer switch the operating mode with DIP switch 4

Starting the function *X.TUNE*

Binary input = 1 → Starting *X.TUNE*.

12.2.9 **OUTPUT (optional) - Configuration of the analog output**

The *OUTPUT* menu item only appears in the selection of auxiliary functions if the positioner has an analog output (optional) or if no parameters have been read in yet.

The analog output can be used for feedback of the current position or of the set-point value to the control center.

Standard signal output: parameter	Position Set-point value	Output of the current position Output of the set-point value
Standard signal output: type	4 – 20 mA 0 – 20 mA	Selection of the unit signal

13 SAFETY END POSITIONS

13.1 Safety end positions after failure of the electrical or pneumatic auxiliary power

Actuator System	Designation	Safety end positions after failure of the auxiliary power	
		electrical	pneumatic
	single-acting control function A	down	not defined
	single-acting control function B	up	not defined

Table 24: Safety positions

14 MAINTENANCE

The positioner Type 8696 is maintenance-free when operated according to the instructions in this manual.

15 DISASSEMBLY

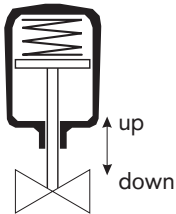
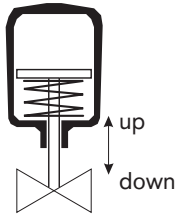
15.1 Safety instructions



DANGER!

Risk of injury from high pressure in the equipment/device.

- ▶ Before working on equipment or device, switch off the pressure and deaerate/drain lines.

Risk of electric shock.

- ▶ Before working on equipment or device, switch off the power supply and secure to prevent reactivation.
- ▶ Observe applicable accident prevention and safety regulations for electrical equipment.



WARNING!

Risk of injury from improper disassembly.

- ▶ Disassembly may be carried out by authorized technicians only and with the appropriate tools.

Risk of injury from unintentional activation of the system and an uncontrolled restart.

- ▶ Secure system from unintentional activation.
- ▶ Following disassembly, ensure a controlled restart.

15.2 Disassembly the positioner

Procedure:

1. Pneumatic connection



DANGER!

Risk of injury from high pressure in the equipment/device.

- ▶ Before working on equipment or device, switch off the pressure and deaerate/drain lines.

→ Loosen the pneumatic connection.

2. Electrical connection



DANGER!

Risk of electric shock.

- ▶ Before working on equipment or device, switch off the power supply and secure to prevent reactivation.
- ▶ Observe applicable accident prevention and safety regulations for electrical equipment.

→ Loosen the circular plug-in connector.

3. Mechanical connection

→ Loosen the fastening screws.

→ Remove the positioner upwards.

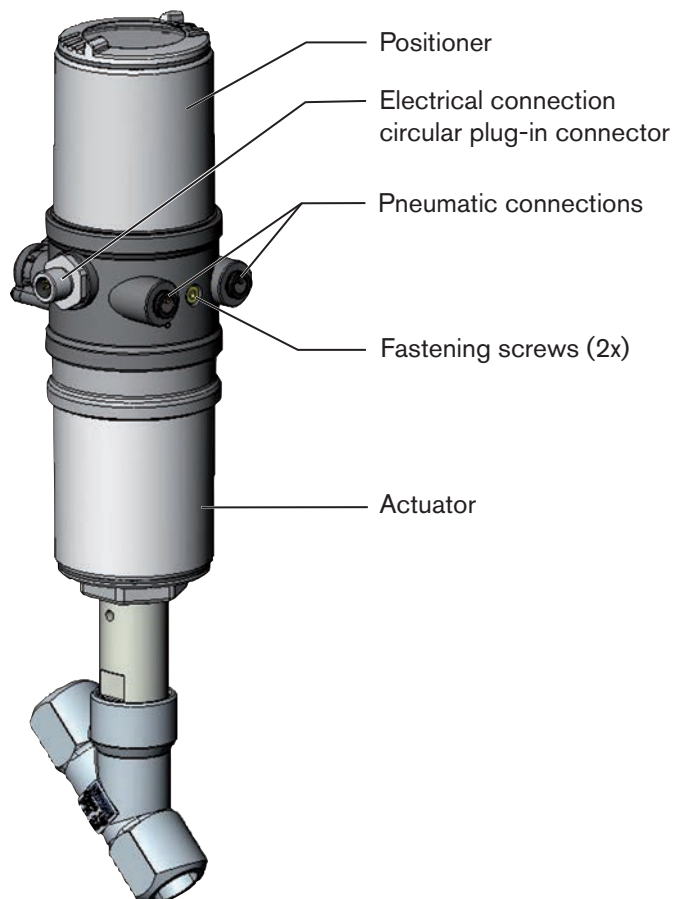

Figure 37: Disassembly the positioner

16 ACCESSORIES

Designation	Order no.
USB adapter for connection to a PC in conjunction with an extension cable	227093
Communicator	Information at www.burkert.com
Connection cable M12 x 1, 8-pole	919061
Assembly tool	647078

Table 25: Accessories

16.1 Communications software

The PC operating program “Communicator” is designed for communication with the devices from the Bürkert positioner family (valid since serial number 20000).



A detailed description and precise schedule of the procedure for the installation and operation of the software can be found in the associated documentation.

16.1.1 USB interface

The PC requires an USB interface for communication with the positioners as well as an additional adapter with interface driver (see “Table 25: Accessories”).

The data transfer must be according to HART specification.

16.1.2 Download

Download the software at: www.burkert.com.

17 PACKAGING AND TRANSPORT

NOTE!

Transport damages.

Inadequately protected equipment may be damaged during transport.

- ▶ During transportation protect the device against wet and dirt in shock-resistant packaging.
- ▶ Avoid the action of heat and cold which can lead to temperatures above or below the admissible storage temperature.

18 STORAGE

NOTE!

Incorrect storage may damage the device.

- ▶ Store the device in a dry and dust-free location.
- ▶ Storage temperature: -20 – +65°C.

19 DISPOSAL

→ Dispose of the device and packaging in an environmentally friendly manner.

NOTE!

Damage to the environment caused by device components contaminated with media.

- ▶ Observe the relevant disposal and environmental protection regulations.



Observe national waste disposal regulations.

