

Data Sheet

Oil Pump type BFP 21 LE - size 3

Application

BFP 21 LE is a special version of the BFP 21 pump. The pump has a connection from the nozzle line back to the suction side. This connection can be turned off by means of the screw K. The BFP 21 LE is designed for domestic burners with limited capacity featuring reduced start/stop emission. Please notice the capacity/pressure diagram.

BFP 21 LE features:

- Light oil domestic oil burners
- Low emission at start and stop
- 1-stage oil burners
- 1- or 2-pipe operation
- Build in solenoid valve cut-off
- Cartridge filter
- Build in pressure regulator

Function

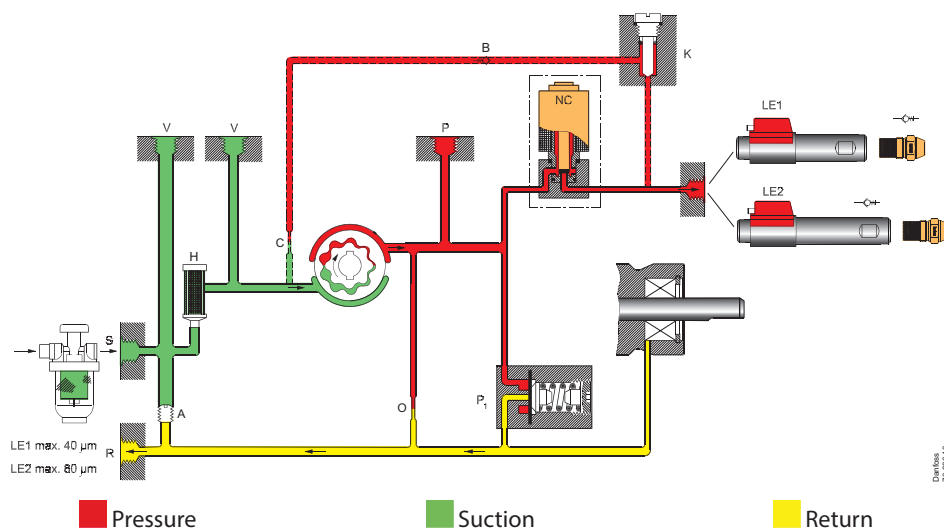

The LE pump is used with either an LE nozzle (System 1) or an LE preheater (System 2). Before burner start the preheater heats up the oil in the nozzle line. The expanding oil is prevented from dripping out of the nozzle because of the connection back to the suction side. The non return valve B inside the pump has an opening pressure of less than 2 bar whereas the LE valve in the nozzle opens at a pressure of 5 ± 1 bar. (The valve in the preheater opens at min. 6 bar.) When the burner starts, the pump build up pressure and the solenoid valve NC opens. The oil pressure will open the LE valve and the nozzle will function as normal. If the LE nozzle is used the pump pressure must be adjusted 1,6 bars above the required nozzle pressure as the valve has a pressure drop of 1,6 bar. If the LE valve in the preheater is used there is no need for pressure correction as this valve has no pressure drop. During operation there will be a loss of oil back to the suction side. This loss is minimized by the restriction C that allows 14 l/h loss at 10 bar. The pump is therefore limited in its capacity compared with a standard pump.

When the burner stops the solenoid valve NC is closed and cuts off the flow to the nozzle. The LE valve secures a fast and tight shut off at the nozzle. If the nozzle line is heated due to radiation from the combustion chamber the LE function will secure that the expanding oil is released back to the suction side and does not drip out the nozzle.

Bleeding

In 2-pipe systems the pump is self-priming, i.e. bleeding is performed via the constriction (O) to the return outlet (R).

In 1-pipe systems with plugged return outlet (R), bleeding must be performed through the nozzle outlet (E) or the pressure gauge port (P).

Warranty

For pumps used outside the stated technical data and used with oil containing abrasive particles Danfoss cannot give any warranty.

Note!

Do not mount the pump with the solenoid valve pointing downwards.

The solenoid valve must be replaced after 250.000 operations or 10 years (approved life expectancy).

Identification

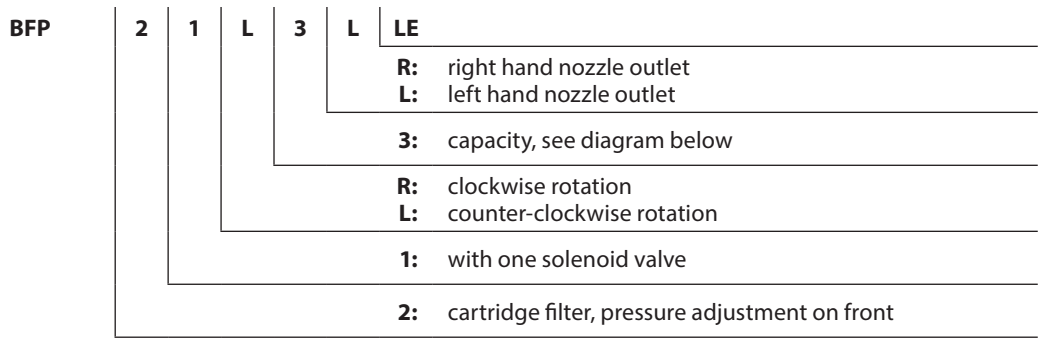

Nozzle capacity at 4.3 cSt, 10 bar, 2800 min⁻¹

Technical Data

BFP 21 LE	3
Oil types	Standard fuel gas oil and fuel gas oil acc. to DIN V 51603-6 EL A Bio-10 (max. 10% FAME)
Viscosity range (measured in suction inlet)	1.8 to 12.0 cSt. (mm ² /s)
Filter area/mesh	11 cm ² /200 μm
Pressure range	7 to 16.5 bar
Default setting	10 ±1 bar
Max. pressure in suction inlet/return outlet	1.5 bar
Speed	2400 to 3450 min ⁻¹
Max. starting torque	0.1 Nm
Ambient/transport temperature	-20 to +70° C
Temperature of medium	-10 to +70° C
Coil power consumption	9 W
Rated voltage (other voltages on request)	230 V, 50/60 Hz
Coil enclosure	IP 40
Shaft/neck	EN 225

Nozzle capacity

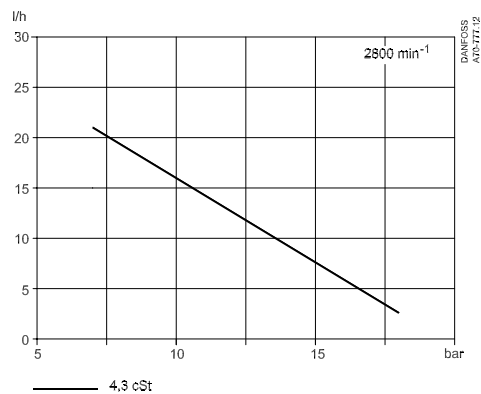

Operating torque

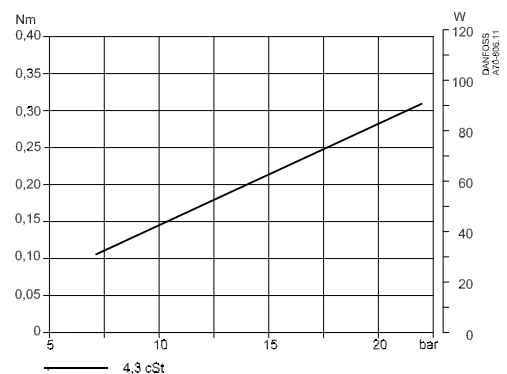

Connections

Example shows BFP 21 L3L LE

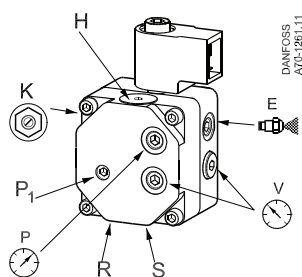

- P₁**: Pressure adjustment
- S**: Suction inlet G 1/4
- R**: Return outlet G 1/4
- E**: Nozzle outlet G 1/8
- K**: LE changeover screw
- P**: Pressure gauge port G 1/8
- V**: Vacuum gauge port G 1/8
- H**: Filter

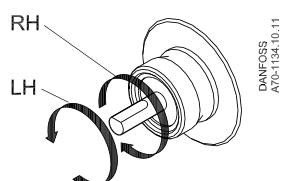

Note! Shaft rotation, location of nozzle outlet and other connections are seen from shaft end.

- RH**: R-rotation
- LH**: L-rotation

Change-over and Filter Replacement

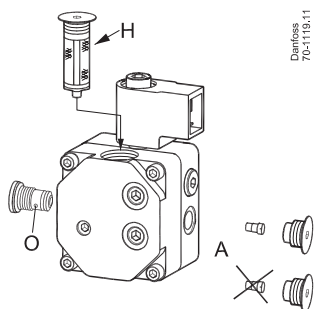

- H**: Filter
- A**: 2-pipe operation, with screw
1-pipe operation, without screw

Dimensions

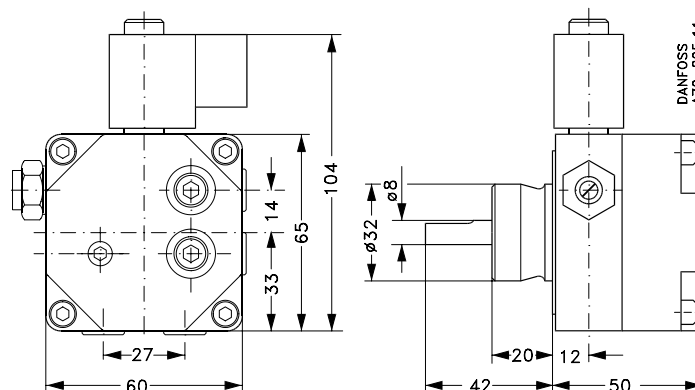

www.burner.danfoss.com