

ProtEX PD8-6080/PD8-6081 Explosion-Proof Modbus® Scanner Instruction Manual



Modbus Scanner

- Modbus® RTU Master, Slave, or Snooper Mode
- Poll and Display up to 16 Process Variables
- Two (2) 0-20 mA, 4-20 mA, 0-5 V, 1-5 V, and ± 10 V Inputs
- Math functions Capabilities
- Isolated 24 VDC @ 25 mA Transmitter Power Supply
- Multi-Pump Alternation Control
- Signal Input Conditioning for Flow & Round Horizontal Tank
- Programmable Displays & Function Keys
- 32-Point, Square Root, or Exponential Linearization
- Up to Three 4-20 mA Analog Outputs Available
- Modern, Sleek and Practical Enclosure
- Display Mountable at 0°, 90°, 180°, & 270° Degrees
- Explosion-Proof, IP68, NEMA 4X Enclosure
- SafeTouch® Through-Glass Button Programming
- Flanges for Wall or Pipe Mounting
- Superluminous Sunlight Readable Display
- Free USB Programming Software & Cable

PRECISION DIGITAL CORPORATION

233 South Street • Hopkinton MA 01748 USA
Tel (800) 343-1001 • Fax (508) 655-8990

PRECISION
DIGITAL

www.predig.com

Disclaimer

The information contained in this document is subject to change without notice. Precision Digital Corporation makes no representations or warranties with respect to the contents hereof; and specifically disclaim any implied warranties of merchantability or fitness for a particular purpose.



Caution

Read complete instructions prior to installation and operation of the scanner.



Warning!

Risk of electric shock or personal injury. Hazardous voltages exist within enclosure. Installation and service should be performed only by trained service personnel.



Warning!

- ***This product is not recommended for life support applications or applications where malfunctioning could result in personal injury or property loss. Anyone using this product for such applications does so at his/her own risk. Precision Digital Corporation shall not be held liable for damages resulting from such improper use.***
- ***Failure to follow installation guidelines could result in death or serious injury. Make sure only qualified personnel perform the installation.***
- ***Never remove the instrument cover in explosive environments when the circuit is live.***
- ***Cover must be fully engaged to meet flameproof/explosion-proof requirements.***
- ***Information in this manual supersedes all enclosure, compliance, and agency approval information included in additional product manuals included with this product.***

Limited Warranty

Precision Digital Corporation warrants this product against defects in material or workmanship for the specified period under “Specifications” from the date of shipment from the factory. Precision Digital’s liability under this limited warranty shall not exceed the purchase value, repair, or replacement of the defective unit.

Registered Trademarks

Modbus® is a Registered Trademark of Schneider Automation Inc. All other trademarks mentioned in this document are the property of their respective owners.

© 2018 Precision Digital Corporation. All rights reserved.

www.predig.com

Table of Contents

Table of Contents -----	3
Table of Figures -----	4
Introduction -----	5
Ordering Information -----	6
Specifications -----	7
Operating Modes -----	7
Master & Snooper Settings -----	7
PV Settings -----	7
Display Settings -----	7
Math Functions -----	8
Serial Communications -----	8
General -----	8
Relays -----	9
Isolated 4-20 mA Transmitter Output -----	9
Digital Inputs & Outputs -----	9
Dual Process Input -----	10
MeterView Pro -----	10
Product Ratings and Approvals; -----	11
Compliance Information -----	12
Safety -----	12
Electromagnetic Compatibility -----	12
Safety Information -----	13
Installation -----	13
Unpacking -----	13
Pre-Installed Conduit/Stopping Plug -----	14
Mounting -----	14
Cover Jam Screw -----	14
Transmitter Supply Voltage Selection (P+, P-) -----	14
Connections -----	15
Required & Factory Wired Connection-----	15
Connectors Labeling-----	16
Power Connections-----	16
Serial Communications Connections-----	17
Using ProVu Serial Adapters-----	19
F4 Digital Input Connections-----	19
Relay Connections-----	19
Switching Inductive Loads-----	20
4-20 mA Output Connections-----	20
Analog Output Transmitter Power Supply-----	20
Interlock Relay Feature-----	21
Analog Input Signal Connections-----	21
Digital I/O Connections-----	23
External Switch Contacts-----	23
Setup and Programming -----	24
Overview -----	24
SafeTouch® Buttons -----	24
Front Panel Buttons and Status LED Indicators -----	25
ScanView Software -----	26
ScanView Installation-----	26
Display Functions & Messages -----	27
Menu Navigation Tip -----	30
Setting Numeric Values -----	30
Main Menu -----	30
Serial Communications (SERIAL) -----	31
Scanner Mode Selection -----	32
Operating Modes (MODE) -----	32
How to Enable Process Variables (PVs) -----	32
Master Mode (MASTER)-----	33
Snooper Mode (SNOOP) -----	34
How to Select 5 or 6-Digit Registers -----	35
Slave Mode (SLAVE)-----	35
Setting Up the Scanner (SETUP) -----	36
Setting Up the Process Variables (PVs) (PV SETUP)-----	37
Setting the Display Decimal Point (disp.dp)-----	37
Setting the Float Decimal Point (FLOAT.P)-----	37
Scaling the PV Display Values (SCALE)-----	38
Scale Menu-----	38
Setting Up the Displays (DISPLAY SETUP) -----	39
Display Line 1 Parameters (LINE 1 DISPLAY)-----	39
Display Line 2 Parameters (LINE 2 DISPLAY)-----	39
Display Intensity (DINT)-----	39
Display Line 1 Menu (LINE 1 DISPLAY)-----	40
Display Line 2 Menu (LINE 2 DISPLAY)-----	41
Setting the Tags (TAG) & Units (UNIT)-----	42
Application Example 1-----	42
Application Example 2-----	45
Setting the Relay Operation (RELAY) -----	46
Relay Setup Menu (RELAY SETUP)-----	46
Setting the Relay Action (act 1)-----	47
Programming Set (set) & Reset (rst) Points-----	47
Setting Fail-Safe Operation (failsf)-----	47
Programming Time Delay (delay)-----	47
Relay Action for Communications Break (break)-----	48
Relay Action for Loss of 4-20 mA Input (Loop Break)-----	48
Relay and Alarm Operation Diagrams -----	48
High Alarm Operation (Set > Reset)-----	48
Low Alarm Operation (Set < Reset)-----	48
High Alarm with Fail-Safe Operation (Set > Reset)-----	49
Low Alarm with Fail-Safe Operation (Set < Reset)-----	49
Pump Alternation Control Operation-----	49
Relay Sampling Operation-----	50
Relay Operation After Communications Break-----	50
Signal Loss or Loop Break Relay Operation-----	51
Time Delay Operation-----	51
Relay Operation Details -----	52
Overview-----	52
Relays Auto Initialization-----	52
Fail-Safe Operation (FAILSAFE)-----	52
Front Panel LEDs-----	52
Latching and Non-Latching Relay Operation-----	53
Non-Latching Relay (RLO)-----	53
Non-Latching Relay (RNO)-----	53
Latching Relay (RLCH)-----	53
Latching Relay (LCLR)-----	53
Acknowledging Relays-----	54
Pump Alternation Control Applications (RLTERN)-----	54
Setting Up the Interlock Relay (Force On) Feature-----	55
Scaling the 4-20 mA Analog Output (ROUT) -----	56
Setting Up the Password (PASS) -----	57
Protecting or Locking the Scanner-----	57
Making Changes to a Password Protected Scanner-----	57
Disabling Password Protection-----	57
Advanced Features Menu -----	58
Advanced Menu Navigation Tips-----	58

Advanced Features Menu & Display Messages ---	59	Troubleshooting -----	76
Scan Function (SCAN)-----	61	Diagnostics Menu (d iAG) -----	77
Control Menu (CONTROL)-----	61	Determining Software Version -----	77
Noise Filter (filter)-----	62	Reset Scanner to Factory Defaults -----	77
Noise Filter Bypass (bypass)-----	62	Testing the Display LEDs -----	77
Rounding Feature (round)-----	62	Scanner Operation -----	78
Select Menu (SELECT)-----	62	Front Panel Buttons Operation -----	78
Analog Output Source Programming (ROUTPR) ----	71	SafeTouch® Buttons -----	79
User Menu (USER)-----	72	Function Keys Operation -----	79
Digital Input Menu (d i i)-----	73	F4 Operation -----	79
Digital Output Menu (d o i)-----	73	Maximum/Minimum Readings -----	79
Reset Menu (RESET)-----	73	Factory Defaults & User Settings -----	80
4-20 mA Output Calibration-----	74	Service -----	82
Input Calibration Menu (ICAL)-----	75	Mounting Dimensions -----	82
Recalibrating the Analog Input Channels (Ch-A &		EU Declaration of Conformity -----	83
Ch-B)-----	75		

Table of Figures

Figure 1. Transmitter Supply Voltage Selection	14	Figure 13. 4-20 mA Output Connections -----	20
Figure 2: Integrated ProVu Required Connections	15	Figure 14. Interlock Connections -----	21
Figure 3. Connector Labeling for Fully Loaded PD6080/6081	16	Figure 15. Transmitters Powered by Internal Supply	21
Figure 4. Power Connections	16	Figure 16. Transmitter Powered by Ext. Supply or Self-Powered	21
Figure 5: ProtEX-MAX Connections to a Serial Converter	17	Figure 17. Voltage Input Connections	22
Figure 6. Three-Wire RS485 Connection	17	Figure 18: Digital I/O Connections	23
Figure 7: RS-485 Wiring	18	Figure 19. Acknowledge Relays with F4 Function Key	54
Figure 8: RS-485 Two-Wire Multi-Drop Wiring	18	Figure 20. Acknowledge Relays with Digital Input	54
Figure 9. F4 Digital Input Connections	19	Figure 21: Enclosure Dimensions – Front View	82
Figure 10. Relay Connections	19	Figure 22: Enclosure Dimensions – Side Cross Section View	82
Figure 11. AC and DC Loads Protection	20		
Figure 12. Low Voltage DC Loads Protection	20		

Introduction

The ProtEX-MAX PD8-6080 Super Snooper Modbus® scanner offers all the functionality of the ProVu PD6080 as a fully FM, CSA, ATEX, and IECEx approved explosion-proof product. It can be programmed as a Modbus RTU Master, Slave, or Snooper. It is capable of scanning up to 16 variables generated by any Modbus device, which makes it ideal for tank level monitoring and control. Its superluminous LED digits make it easily readable in smoke, dust, fog, and, with the optional SunBright® display, even direct sunlight. The PD8-6080 displays in decimal format, while the PD8-6081 displays in Feet & Inches.

As a master, the PD8-6080/1 reads up to 16 slave devices, scales the data from each, displays the result, and operates the internal relays and 4-20 mA output. The PD8-6080/1 in Master mode is capable of polling up to 16 process variables (PVs); it displays all the enabled PVs in sequence, at a user programmable scan rate; it also allows other PD8-6080/1s in Snooper mode to read any of the variables being polled by the master. As a snooper, the PD8-6080/1 listens to the Modbus traffic and picks up a specific register or registers being polled by a master device from a specific slave device and processes the data being read. As a slave, it is controlled by a master device. The data sent to it by the master is scaled, displayed, and used to operate the relays and 4-20 mA output.

Data is displayed on an adjustable intensity, dual-line, six-digit display. Its superluminous LED digits make it easily readable in smoke, dust, fog, and direct sunlight. The upper display is a 0.6 inch, seven-segment LED display, while the lower display digit height is 0.46 inches. The scanner can be powered from 85-265 VAC or 12-36 VDC. It is available with up to 4 internal relays and 4 digital inputs/outputs.

The PD8-6080/6081 comes equipped with dual analog input channels (4-20 mA and/or 0-10 VDC) for use in Master Mode. These can be assigned to mA or volts by mapping a PV to the internal scanner addresses 256-259, depending on the desired function.

Various math functions may be applied to the Modbus and analog inputs including addition, difference, absolute difference, average, weighted average, multiplication, division, minimum, maximum, draw, ratio, and concentration. This is in addition to the signal input conditioning functions (linear, square root, programmable exponent, or round horizontal tank calculations). The displays, relays, and the analog outputs may be assigned to PVs or to math channels C1, C2, C3, or C4. The digital inputs/outputs can be custom-programmed for specific operations. A digital input (F4) is standard.

Free ScanView software allows the Modbus Scanner to be programmed directly from a PC using the onboard USB connection. Configure multiple scanners, conveniently monitor critical information, and Datalog right from a PC with ease, further increasing plant efficiency.

Ordering Information

Standard Display Models

85-265 VAC Power Model	12/24 VDC Power Model	Options Installed
PD6080-6H0	PD6080-7H0	No options
PD6080-6H7	PD6080-7H7	4 relays & 4-20 mA output

Feet & Inches Display Models

PD6081-6H0	PD6081-7H0	No options
PD6081-6H7	PD6081-7H7	4 relays & 4-20 mA output



WARNING - Cancer and Reproductive Harm - www.P65Warnings.ca.gov

Accessories

Model	Description
PDA1485	RS-485 serial adapter - (Included with PD6080 and PD6081)
PDA7485-I	RS-232 to RS-422/485 isolated converter
PDA8485-I	USB to RS-422/485 isolated converter
PDX6901	Suppressor (snubber): 0.01 μ F/470 Ω , 250 VAC

Specifications

Except where noted all specifications apply to operation at +25°C.

Operating Modes

Master	Processes data read from Modbus RTU slave devices. It polls up to 16 process variables from 1 to 16 slave devices. The Master is capable of scanning the selected PVs, scaling the data, triggering relays, performing math operations, and driving the analog outputs.
Snooper	Listens to the Modbus traffic and picks up a specific register or registers being polled by a master device from a specific slave device and processes the data being read. The Snooper mode handles the data the same way as the Master.
Slave	Processes data sent to it from a Modbus RTU master device.

Note: The relays and the 4-20 mA outputs are functional in all modes.

Master & Snooper Settings

PV Number	PV1–PV16 Enable or disable the process variables to be polled by the Master.
Slave Id	Assign the slave ID or address (1-247, 256-259 for mA or volts inputs) containing the process variables to be displayed by the selected PV.
Function Code	Select which Modbus function code (03, 04, or 65) to use in reading the slave device.
Register Number	5 digit: 30001-39999, 40001-49999, or 1-65,536 6 digit: 300001-365536 or 400001-465536 (Function Code 65 N/A here) Specifies which register(s) to read in the slave device. Range is dependent on Function Code selection (65, 04, or 03) and digits selection (5 or 6).
Data Type	Select the data format that the slave device uses. Select between Short integer (2 byte), Long integer (4 byte), or floating point (4 byte), Signed or Unsigned (integer only) and byte order: 1234, 4321, 2143, or 3412 (big-endian vs. little-endian, or swapped).
Poll Time	1.0 to 99.9 sec. Time between read-commands (Master mode).
Slave Response Timeout	0.0 to 99.9 seconds: Time allowed for the slave to respond before the scanner generates a communication break condition. The master polls the slave 3 times before starting the response timeout timer. Slave/Snooper mode: Time the scanner will wait for new data before going into break condition. Slave mode: Programming 0 disables the timeout; the last value received will be displayed indefinitely.

Communication Break	Displays "brEAK" after the Master has polled the slave device 3 times and the response timeout has elapsed. The Snooper and Slave modes go into break condition after no new data is received within the response timeout window. Relays can be programmed to go on, off, or ignore the break condition. The analog outputs can be setup to generate a fixed mA current when a break condition is detected.
----------------------------	---

PV Settings

Tag & Units	6-character, independent tag and units for each PV and math channel
PV Format	PD6080 default: Decimal format PD6081 default: FT & IN, 1/8 th or 1/16 th ; decimal format may be selected for bottom display indication.
Display Decimal Point	Up to five decimal places or none: d.ddddd , dd.dddd , ddd.ddd , dddd.dd , ddddd.d , or dddddd
Float Decimal Point	Select the number of decimals to use for the floating point data expected from the slave or master device (this is independent from the display decimal point selection).
Pv & Math Scaling	All PVs and math channels may be scaled to represent the input data in any engineering unit. Example: Level transmitter = 999.999 inches; to display in Ft-In-1/16 th scale input 2 to display 83 Ft – 4 In – 0/16 th .

Display Settings

Scan Mode	Automatic: 1.0 to 99.9 sec Manual: Front panel or digital inputs Go on alarm: Continues scanning after an alarm is detected Stop on alarm: Goes to the alarmed PV and stops scanning; press Scan to resume scanning.
Display Scan Rate	Master/Snooper: 1 PV/second to 1 PV every 99.9 seconds Slave: Dependent on master device (e.g. PLC) <i>Note: The display scan rate is independent of the poll time.</i>
Display Assignment	Display line 1 may be assigned to PV (process values), Ch-C (math channel), PV & units, tag & PV, tag-PV-units, C & units, tag-C-unit, Set point 1-4, max/min PV, max/min C. Line 2 may be assigned to all of the above, tag, tag & units, or off. The tag and units are displayed alternately for 2 sec max, when selected. Different tags & PVs may be selected to display on line 1 & 2 at the same time.

Math Functions

Name	Math Operation (Examples) (P = Adder, F = Factor)	Setting
Addition	$(PV1+PV2+P)*F$	Summ
Difference	$(PV1-PV2+P)*F$	diF
Absolute difference	$((Abs(PV1- PV2)+P)*F$	diFAbs
Average	$((PV1+PV2)/2)+P)*F$	AvG
Multiplication	$((PV1*PV2)+P)*F$	Nmulti
Division	$((PV1/PV2)+P)*F$	divide
Max PV	Max value of all selected PVs	Hi-pv
Min PV	Min value of all selected PVs	Lo-pv
Draw	$((PV1/PV2)-1)*F$	drAuw
Weighted average	$((PV2-PV1)*F)+PV1$	uwavg
Ratio	$(PV1/PV2)*F$	Ratio
Concentration	$(PV1/(PV1+PV2))*F$	Concen
Math 2	Math on other math channels	Nmath2

Programmable Constants
 Constant P (Adder): -99.999 to 999.999, default: 0.000
 Constant F (Factor): 0.001 to 999.999, default: 1.000

Serial Communications

Compatibility	EIA-485
Connectors	Removable screw terminal connector
Max Distance	3,937' (1,200 m) max
Status Indication	Separate LEDs for Power (P), Transmit (TX), and Receive (RX)
Scanner Id	1 – 247 (Scanner Modbus address)
Baud Rate	300 – 19,200 bps
Transmit Time Delay	Programmable 0 to 4999 ms This is the time the scanner will wait for a slave to respond before sending another request on the bus. This value should be greater than 100 ms to avoid collisions on the bus.
Data	8 bits (1 start bit, 1 or 2 stop bits)
Parity	Even, Odd, or None with 1 or 2 stop bits
Byte-To-Byte Timeout	0.01 – 2.54 second
Turn Around Delay	Less than 2 ms (fixed)

Note: Refer to the PROVu® Scanner Modbus Register Tables located at www.predig.com.

General

Input/output	Modbus RTU over RS-485, Two analog inputs (4-20 mA, ±10 V)
Display	Line 1: 0.60" (15 mm) high, red LEDs Line 2: 0.46" (12 mm) high, red LEDs 6 digits each (-99999 to 999999), with lead zero blanking
Display Intensity	Eight user selectable intensity levels
Overrange	Values greater than 999999 cause the display to flash 999999

Underrange	Values less than -99999 cause the display to flash -99999
Programming Methods	Four front panel buttons, digital inputs, PC and ScanView software, or Modbus registers.
Max/Min Display	Max/min readings are stored until reset by the user or when power to the scanner is turned off. User can reset by front panel pushbuttons, digital input, or via Modbus registers.
Password	Three programmable passwords restrict modification of programmed settings. Pass 1: Allows use of function keys and digital inputs Pass 2: Allows use of function keys, digital inputs and editing set/reset points Pass 3: Restricts all programming, function keys, and digital inputs.
F4 Digital Input Contacts	50k ohm pull-up to 3.3 VDC. Connect normally open contacts across F4 to COM.
F4 Digital Input Logic Levels	Logic High: 3 to 5 VDC Logic Low: 0 to 1.25 VDC
Non-Volatile Memory	All programmed settings are stored in non-volatile memory for a minimum of ten years, with or without power.
Power Options	85-265 VAC 50/60 Hz, 90-265 VDC, 20 W max or 12/24 VDC ± 10%, 15 W max Powered over USB for configuration only.
Fuse	Required external fuse: UL Recognized, 5 A max, slow blow; up to 6 scanners may share one 5 A fuse
Isolated Transmitter Power Supply	Terminals P+ & P- : 24 VDC ± 10%. Selectable for 24, 10, or 5 VDC supply (internal jumper J4). All models transmitter supply rated @ 25 mA max.
Isolation	4 kV input/output-to-power line. 500 V input-to-output or output-to-P+ supply
Overvoltage Category	Installation Overvoltage Category II: Local level with smaller transient overvoltages than Installation Overvoltage Category III.
Environmental	T6 Class operating temperature range Ta = -40 to 60°C T5 Class operating temperature range Ta = -40 to 65°C
Max Power Dissipation	Maximum power dissipation limited to 15.1 W.
Connections	Screw terminals accept 12 to 22 AWG wire
Enclosure	Explosion-proof die cast aluminum with glass window, corrosion resistant epoxy coating, color: blue. NEMA 4X, 7, & 9, IP68. Default conduit connections: Four ¾" NPT threaded conduit openings and two ¾" NPT metal conduit plugs with 12 mm hex key fitting installed. Additional conduit opening configurations may be available; verify quantity and sizes on specific device labeling during installation.
Mounting	Four slotted flanges for wall mounting or NPS 1½" to 2½" or DN 40 to 65 mm pipe mounting. See Mounting Dimensions on page 82.

Tightening Torque	Screw terminal connectors: 5 lb-in (0.56 Nm)
Overall Dimensions	6.42" x 7.97" x 8.47" (W x H x D) (163 mm x 202 mm x 215 mm)
Approximate Shipping Weight	16.0 lbs (7.26 kg)
Warranty	3 years parts and labor

Relays

Rating	4 SPDT (Form C) internal and/or 4 SPST (Form A) external; rated 3 A @ 30 VDC and 125/250 VAC resistive load; 1/14 HP (\approx 50 W) @ 125/250 VAC for inductive loads
Noise Suppression	Noise suppression is recommended for each relay contact switching inductive loads.
Electrical Noise Suppression	A suppressor (snubber) should be connected to each relay contact switching inductive loads to prevent disruption to the microprocessor's operation. Recommended suppressor value: 0.01 μ F/470 Ω , 250 VAC (PDX6901).
Deadband	0-100% of span, user programmable
High or Low Alarm	User may program any alarm for high or low trip point. Unused alarm LEDs and relays may be disabled (turn off).
Relay Operation	Automatic (non-latching) Latching (requires manual acknowledge) Sampling (based on time) Pump alternation control (2 to 4 relays) Off (disable unused relays and enable Interlock feature) Manual on/off control mode
Relay Reset	User selectable via front panel buttons, digital inputs, or PC <ol style="list-style-type: none"> Automatic reset only (non-latching), when the input passes the reset point. Automatic + manual reset at any time (non-latching) Manual reset only, at any time (latching) Manual reset only after alarm condition has cleared (L) <p><i>Note: Front panel button or digital input may be assigned to acknowledge relays programmed for manual reset.</i></p>
Time Delay	0 to 999.9 seconds, on & off relay time delays Programmable and independent for each relay
Fail-Safe Operation	Programmable and independent for each relay. <i>Note: Relay coil is energized in non-alarm condition. In case of power failure, relay will go to alarm state.</i>
Auto Initialization	When power is applied to the scanner, relays will reflect the state of the input to the scanner.

Isolated 4-20 mA Transmitter Output

Output Source	PV1-16, math channels C1-4, set points 1-4, or manual control mode		
Scaling Range	1.000 to 23.000 mA for any display range		
Calibration	Factory calibrated: 4.000 to 20.000 = 4-20 mA output		
Analog Out Programming	23.000 mA maximum for all parameters: Overrange, underrange, max, min, and break		
Communication Break	Programmable mA output when a slave device does not reply within the response timeout.		
Accuracy	\pm 0.1% of span \pm 0.004 mA		
Temperature Drift	0.4 μ A/ $^{\circ}$ C max from 0 to 65 $^{\circ}$ C ambient, 0.8 μ A/ $^{\circ}$ C max from -40 to 0 $^{\circ}$ C ambient. <i>Note: Analog output drift is separate from input drift.</i>		
Isolated Transmitter Power Supply	Terminals I+ & R: 24 VDC \pm 10%. May be used to power the 4-20 mA output or other devices. Refer to Figure 3 on page 16 and Figure 13 on page 20. All models @ 25 mA max.		
External Loop Power Supply	35 VDC maximum		
Output Loop Resistance	Power supply	Minimum	Maximum
	24 VDC	10 Ω	700 Ω
	35 VDC (external)	100 Ω	1200 Ω

Digital Inputs & Outputs

Channels	4 digital inputs & 4 digital outputs		
Digital Input Logic High	3 to 5 VDC		
Digital Input Logic Low	0 to 1.25 VDC		
Digital Output Logic High	3.1 to 3.3 VDC		
Digital Output Logic Low	0 to 0.4 VDC		
Source Current	10 mA maximum output current		
Sink Current	1.5 mA minimum input current		
+5 V Terminal	To be used as pull-up for digital inputs only. Connect normally open pushbuttons across +5 V & DI 1-4.		
		DO NOT use +5 V terminal (pin 1) to power external devices.	
Function Assignment	The on-board digital inputs (1-4) are designed to mimic the behavior of the front panel buttons (Menu, F1, F2, & F3). If you wish to change their behavior, re-assign F1-F3 to the desired function, then change the corresponding digital input to match.		

Dual Process Input

Two Inputs	Two non-isolated analog inputs, each separately field selectable: 0-20 mA, 4-20 mA; ±10 V (0-5, 1-5, 0-10 V)
PV Analog Channel ID	Ch-A mA: Assign PV to ID 256 or Ch-A volt: 257; Ch-B mA: Assign PV to ID 258 or Ch-B volt: 259
Accuracy	±0.03% of calibrated span ±1 count, square root & programmable exponent accuracy range: 10-100% of calibrated span
Temperature Drift	0.005% of calibrated span/°C max from 0 to 65°C ambient, 0.01% of calibrated span/°C max from -40 to 0°C ambient
Signal Input Conditioning	Linear, square root, programmable exponent, or round horizontal tank volume calculation
Multi-Point Linearization	2 to 32 points for PV1 and PV2
Programmable Exponent	1.0001 to 2.9999
Low-Flow Cutoff	0-999999 (0 disables cutoff function) for PV1 and PV2

Calibration Range	Input Range 4-20 mA ±10 V An error message will appear if the input 1 & input 2 signals are too close together.	Minimum Span Input 1 & Input 2 0.15 mA 0.01 V
Input Impedance	Voltage ranges: greater than 500 kΩ Current ranges: 50 - 100 Ω (depending on resettable fuse impedance)	
Input Overload	Current input protected by resettable fuse, 30 VDC max. Fuse resets automatically after fault is removed.	
HART Transparency	Analog input will not interfere with existing HART communications on the wired 4-20 mA signal	

MeterView Pro

System Requirements	Microsoft® Windows® XP/Vista/7/8/10
Communications	USB 2.0 (Standard USB A to Micro USB B)
Configuration	Configure device settings one at a time

Product Ratings and Approvals;

FM	Enclosure: Type 4X; IP66 Class I, Division 1, Groups B, C, D Class II, Division 1, Groups E, F, G Class III, Division 1, T5/T6 Class I, Zone 1, AEx d, IIC Gb T5/T6 Zone 21, AEx tb IIIC T90°C; Ta -40°C to +65°C T6 Ta = -40°C to +60°C; T5 Ta = -40°C to +65°C Certificate Number: 3047283
CSA	Class I, Division 1, Groups B, C, D Class II, Division 1, Groups E, F, G Class III, Division 1 Class I Zone 1 Ex d IIC Zone 21 Ex tb IIIC T90°C -40°C < Tamb. < +60° C; Temperature Code T6 -40°C < Tamb. < +65° C; Temperature Code T5 Enclosure Type 4X & IP66 Certificate Number: 2531731
ATEX	 II 2 G D Ex d IIC T* Gb Ex tb IIIC T90°C Db IP68 Ta = -40°C to +*°C *T6 = -40°C to +60°C *T5 = -40°C to +65°C Certificate number: Sira 12ATEX1182
IECEX	Ex d IIC T* Gb Ex tb IIIC T90°C Db IP68 Ta = -40°C to +*°C *T6 = -40°C to +60°C *T5 = -40°C to +65°C Certificate Number: IECEX SIR 12.0073

Special Conditions for Safe Use:

Use suitably certified and dimensioned cable entry device and/or plug. The equipment shall be installed such that the supply cable is protected from mechanical damage. The cable shall not be subjected to tension or torque. If the cable is to be terminated within an explosive atmosphere, then appropriate protection of the free end of the cable shall be provided. Cable must be suitable for 90°C.

Year of Construction

This information is contained within the serial number with the first four digits representing the year and month in the YYMM format.

For European Community: The ProtEX-MAX must be installed in accordance with the ATEX directive 94/9/EC, and the product certificate Sira 12ATEX1182.

Compliance Information

Safety

UL & c-UL Listed	USA & Canada UL 508 Industrial Control Equipment
UL File Number	E160849
Front Panel	UL Type 4X, NEMA 4X, IP65; panel gasket provided
Low Voltage Directive	EN 61010-1:2010 Safety requirements for measurement, control, and laboratory use

Electromagnetic Compatibility

Emissions	EN 55022:2010 Class A ITE emissions requirements
Radiated Emissions	Class A
AC Mains Conducted Emissions	Class A
Immunity	EN 61326-1:2013 Measurement, control, and laboratory equipment EN 61000-6-2:2005 EMC heavy industrial generic immunity standard
RFI - Amplitude Modulated	80 -1000 MHz 10 V/m 80% AM (1 kHz) 1.4 - 2.0 GHz 3 V/m 80% AM (1 kHz) 2.0 - 2.7 GHz 1 V/m 80% AM (1 kHz)
Electrical Fast Transients	±2kV AC mains, ±1kV other
Electrostatic Discharge	±4kV contact, ±8kV air
RFI - Conducted	10V, 0.15-80 MHz, 1kHz 80% AM
AC Surge	±2kV Common, ±1kV Differential
Surge	1KV (CM)
Power-Frequency Magnetic Field	30 A/m 70%V for 0.5 period
Voltage Dips	40%V for 5 & 50 periods 70%V for 25 periods
Voltage Interruptions	<5%V for 250 periods

Note:

Testing was conducted on PD6000 Series meters installed through the covers of grounded metal enclosures with cable shields grounded at the point of entry representing installations designed to optimize EMC performance.

Declaration of Conformity available at www.predig.com

Safety Information



WARNINGS

- Read complete instructions prior to installation and operation of the instrument.
- Installation and service should be performed only by trained service personnel. Service requiring replacement of internal sub-components must be performed at the factory.
- Disconnect from supply before opening enclosure. Keep cover tight while circuits are alive. Conduit seals must be installed within 18" (450mm) of the enclosure or within 2" (50mm) for Zone installations.
- Verify that the operating atmosphere of the instrument is consistent with the appropriate hazardous locations certifications.
- If the instrument is installed in a high voltage environment and a fault or installation error occurs, high voltage may be present on any lead
- Read all product labels completely and follow all instructions and requirements listed on the labels for installation or service.

Installation

Install in accordance with applicable local and national regulations (e.g. NEC).

For Installation in USA: The ProtEX-MAX must be installed in accordance with the National Electrical Code (NEC) NFPA 70.

For Installation in Canada: The ProtEX-MAX must be installed in accordance with the Canadian Electrical Code CSA 22.1. All power supplies below 36 V and input circuits must be derived from a CSA Approved Class 2 source.

For European Community: The ProtEX-MAX must be installed in accordance with the ATEX directive 94/9/EC and the product certificate Sira 12ATEX1182.



WARNING

Disconnect from supply before opening enclosure. Keep cover tight while circuits are alive. Conduit seals must be installed within 18" (450mm) of the enclosure or within 2" (50mm) for Zone installations.

Wiring connectors are accessed by opening the enclosure. To access electrical connectors, remove the 2 captive screws and then remove the electronics module. Connectors are on the rear of the electronics module.

Unpacking

Remove the instrument from packing box. Inspect the packaging and contents for damage. Report damages, if any, to the carrier.

If any part is missing or the instrument malfunctions, please contact your supplier or the factory for assistance.

Pre-Installed Conduit/Stopping Plug

The PD8-6000 is supplied with two pre-installed conduit plugs for installations that do not require the use of all conduit entries. The conduit/stopping plugs include an internal 12mm hexagonal socket recess for removal. The pre-installed plugs and their installation are included in the hazardous area approvals for the PD8 series enclosure.

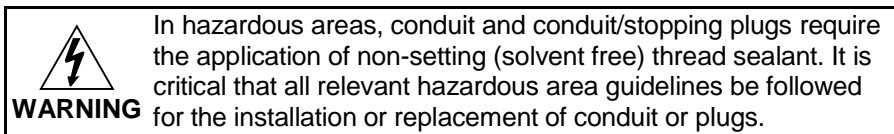

Mounting

The ProtEX-MAX has four slotted mounting flanges that should be used for pipe mounting or wall mounting. Refer to *Mounting Dimensions*, page 82 for details.

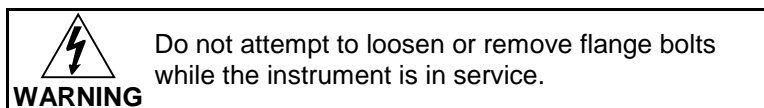

Cover Jam Screw

The cover jam screw should be properly installed once the instrument has been wired and tested in a safe environment. The cover jam screw is intended to prevent the removal of the instrument cover in a flameproof environment without the use of tools. Using a M2 hex wrench, turn the screw clockwise until the screw contacts the aluminum enclosure. Turn the screw an additional 1/4 to 1/2 turn to secure the cover. Caution: Excess torque may damage the threads and/or wrench.

Transmitter Supply Voltage Selection (P+, P-)

All scanners, including models equipped with the 12/24 VDC power option, are shipped from the factory configured to provide 24 VDC power for the transmitter or sensor. If the transmitter requires 5 or 10 VDC excitation, the internal jumper J4 must be configured accordingly.

To access the voltage selection jumper:

1. Remove all the wiring connectors.
2. Unscrew the back cover.
3. Slide out the back cover by about 1 inch.
4. Configure the J4 jumper, located behind the input signal connector, for the desired excitation voltage as shown.

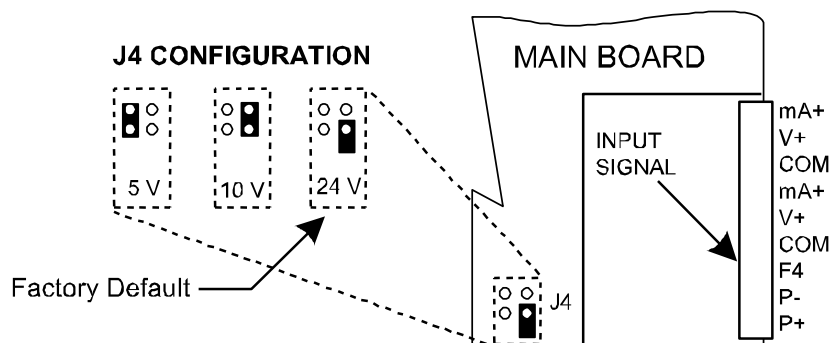



Figure 1. Transmitter Supply Voltage Selection

Connections



WARNINGS

- **Static electricity can damage sensitive components.**
- **Observe safe handling precautions for static-sensitive components.**
- **Use proper grounding procedures/codes.**
- **If the instrument is installed in a high voltage environment and a fault or installation error occurs, high voltage may be present on any lead or terminal.**
- **Follow all fusing and wiring precautions requirements for the instrument integrated to the PD8 Series model number being connected.**

To access the connectors, remove the enclosure cover and unscrew the two captive screws that fasten the electronics module. Signal connections are made to de-pluggable connectors on the back of the electronics module.

Some connectors may be provided already connected. These connections are required for proper operation of the ProtEX-MAX, and should not be removed unless instructed to by this manual.

Wires marked as being used for testing purposes should be removed.

Grounding connections are made to the two ground screws provided on the base – one internal and one external.

After all connections have been completed and verified, apply power to the unit.

Required & Factory Wired Connection

The ProtEX-MAX comes with a pre-wired connection. This connection is detailed below, and must be maintained in order for the instrument to function properly.



WARNING

Observe all safety regulations. Electrical wiring should be performed in accordance with all agency requirements and applicable national, state, and local codes to prevent damage to the meter and ensure personnel safety.

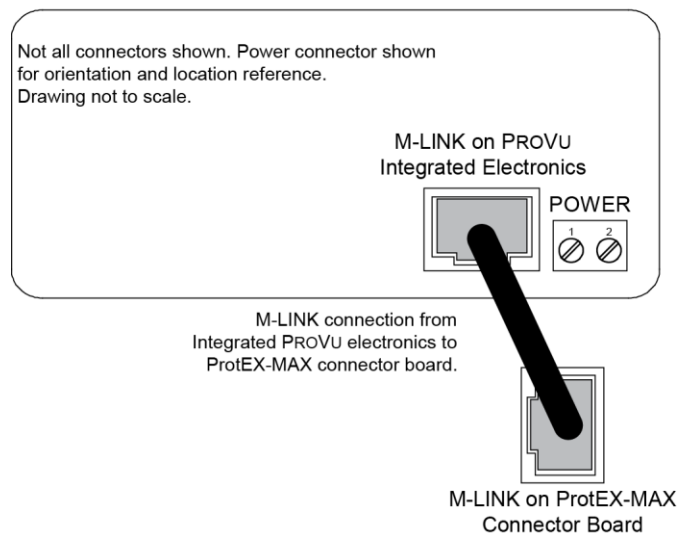



Figure 2: Integrated ProVu Required Connections

Connectors Labeling

The connectors' label, affixed to the scanner, shows the location of all connectors available with requested configuration.



Warning! Do not connect any equipment other than Precision Digital's expansion modules, cables, or scanners to the RJ45 M-LINK connector. Otherwise damage will occur to the equipment and the scanner.

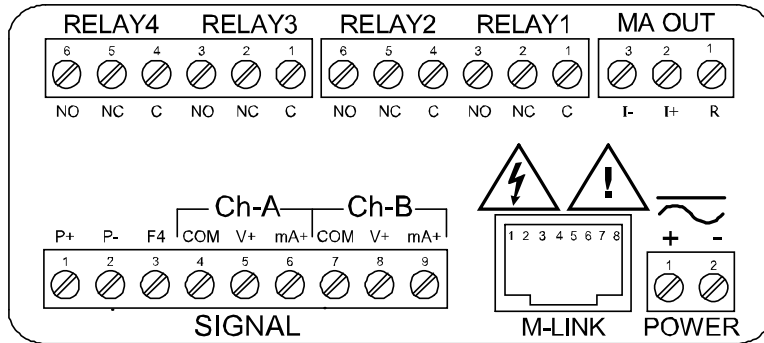

Figure 3. Connector Labeling for Fully Loaded PD6080/6081

Power Connections

Power connections are made to a two-terminal connector labeled POWER on the back of the scanner. The scanner will operate regardless of DC polarity connection. The + and - symbols are only a suggested wiring convention.

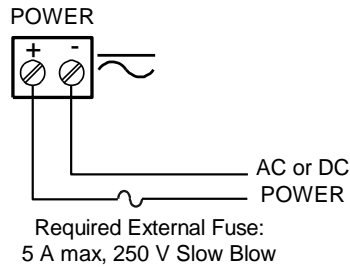

Figure 4. Power Connections

Serial Communications Connections

The ProtEX-MAX has a 5 position terminal block for connecting RS-485 serial devices.

Figure 5 details the wiring connections from the ProtEX-MAX to an RS-485 serial converter (such as the PDA7485 or PDA8485) for a four-wire network.

ProtEX-MAX to RS-485 Serial Converter Connections	
RS-485 Serial Converter	ProtEX-MAX RS- 485 Connections
\perp	\perp
\overline{DO}	\overline{DI}
DO	DI
\overline{DI}	\overline{DO}
DI	DO

Figure 5: ProtEX-MAX Connections to a Serial Converter

The ProtEX-MAX has three diagnostic LEDs: a Power (P) LED to show when the module is powered properly, a Transmit Data (TX) LED to show when the module is being transmitted to by the PC side, and a Receive Data (RX) LED to show when the module is sending data to a receiving device.

The following diagrams detail how to connect the RS-485 serial communications from the ProtEX-MAX to a RS-485/RS-232 serial converter (PDA7485) in four wire and two wire configurations.

Three Wire Connections

In order to wire the 5 pins for use as a 3-wire half-duplex RS-485 connection, it is necessary to create a jumper connection between DI – DO and \overline{DI} – \overline{DO} as shown below.

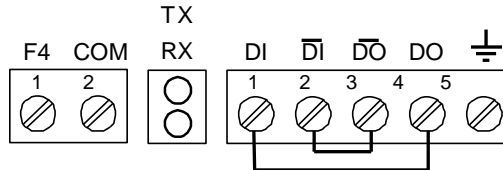

Figure 6. Three-Wire RS485 Connection

Notes:

1. Termination resistors are optional and values depend on the cable length and characteristic impedance. Consult the cable manufacturer for recommendations.
2. Refer to RS-232 to RS-485 Converter documentation for further details.
3. Use shielded cable, twisted-pairs plus ground. Connect ground shield only at one location.

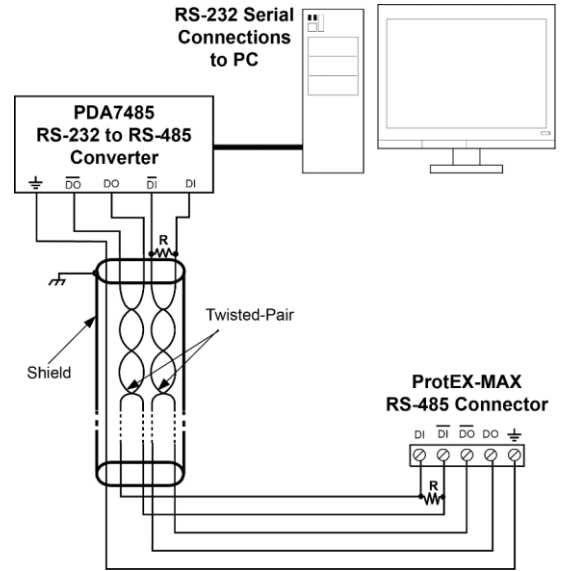

Figure 7: RS-485 Wiring



Observe all safety regulations. Electrical wiring should be performed in accordance with all agency requirements and applicable national, state, and local codes to prevent damage to the meter and ensure personnel safety.

Notes:

1. Termination resistors are optional and values depend on the cable length and characteristic impedance. Consult the cable manufacturer for recommendations.
2. Refer to RS-232 to RS-485 Converter documentation for further details.
3. Use shielded cable, twisted-pair plus ground. Connect ground shield only at one location.

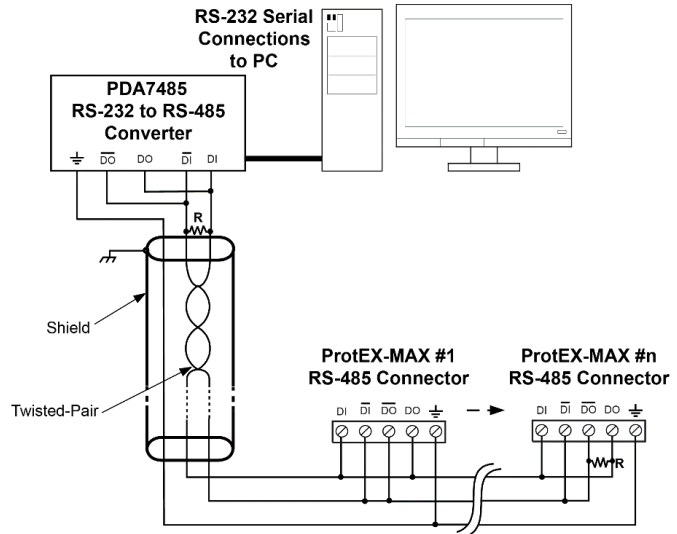



Figure 8: RS-485 Two-Wire Multi-Drop Wiring



Observe all safety regulations. Electrical wiring should be performed in accordance with all agency requirements and applicable national, state, and local codes to prevent damage to the meter and ensure personnel safety.

When using more than one instrument in a multi-drop or multi-point mode, each meter must be provided with its own unique address.

Using PROVu Serial Adapters

 NOTICE	PROVu expansion modules and serial adapters are not included in the hazardous area approvals of the ProtEX-MAX. The PDA1232 may be used only while the ProtEX-MAX is in a safe area, and will disable some features while installed.
--	--

PROVu expansion modules and serial adapters are not recommended for use with the ProtEX-MAX. It is recommended that any serial protocol conversion required on the RS-485 communications connection be performed using a PDA7485 RS-232 to RS-485 or PDA8485 USB to RS-485 serial converter located in a safe area.

F4 Digital Input Connections

A digital input, F4, is standard on the scanner. This digital input connected with a normally open closure across F4 and COM, or with an active low signal applied to F4.

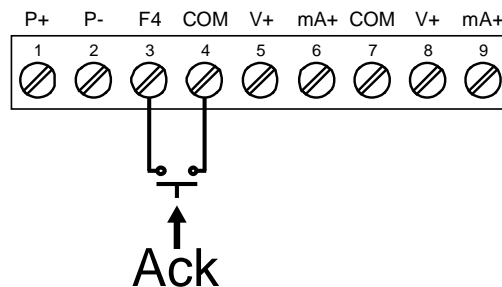

Figure 9. F4 Digital Input Connections

Relay Connections

Relay connections are made to two six-terminal connectors labeled RELAY1 – RELAY4 on the back of the scanner. Each relay’s C terminal is common only to the normally open (NO) and normally closed (NC) contacts of the corresponding relay. The relays’ C terminals should not be confused with the COM (common) terminal of the INPUT SIGNAL connector.

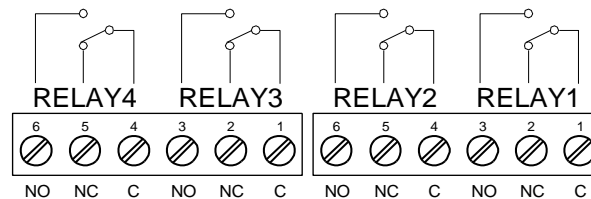

Figure 10. Relay Connections

Switching Inductive Loads

The use of suppressors (snubbers) is strongly recommended when switching inductive loads to prevent disrupting the microprocessor's operation. The suppressors also prolong the life of the relay contacts. Suppression can be obtained with resistor-capacitor (RC) networks assembled by the user or purchased as complete assemblies. Refer to the following circuits for RC network assembly and installation:

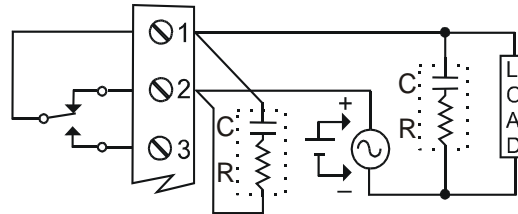

Figure 11. AC and DC Loads Protection

Choose R and C as follows:

- R: 0.5 to 1 Ω for each volt across the contacts
- C: 0.5 to 1 μF for each amp through closed contacts

Notes:

1. Use capacitors rated for 250 VAC.
2. RC networks may affect load release time of solenoid loads. Check to confirm proper operation.
3. Install the RC network at the scanner's relay screw terminals. An RC network may also be installed across the load. Experiment for best results.

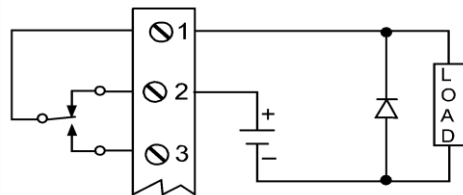

Use a diode with a reverse breakdown voltage two to three times the circuit voltage and forward current at least as large as the load current.

Figure 12. Low Voltage DC Loads Protection

RC Networks Available from Precision Digital

RC networks are available from Precision Digital and should be applied to each relay contact switching an inductive load. Part number: PDX6901.

Note: Relays are de-rated to 1/14 HP (50 watts) with an inductive load.

4-20 mA Output Connections

Connections for the 4-20 mA transmitter output are made to the connector terminals labeled MA OUT. The 4-20 mA output may be powered internally or from an external power supply.

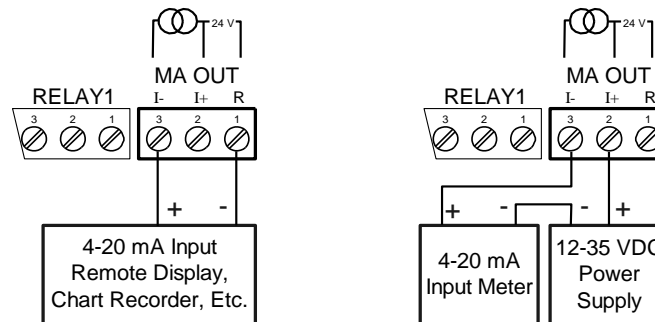

Figure 13. 4-20 mA Output Connections

Analog Output Transmitter Power Supply

The internal 24 VDC power supply powering the analog output may be used to power other devices, if the analog output is not used. The I+ terminal is the +24 V and the R terminal is the return.

Interlock Relay Feature

As the name implies, the interlock relay feature reassigns one, or more, alarm/control relays for use as interlock relay(s). Interlock contact(s) are wired to digital input(s) and trigger the interlock relay. This feature is enabled by configuring the relay and relative digital input(s). In one example, dry interlock contacts are connected in series to one digital input which will be used to force on (energize) the assigned interlock power relay when all interlock contacts are closed (safe). The interlock relay front panel LED flashes when locked out. The interlock relay would be wired in-series with the load (N/O contact). See below.

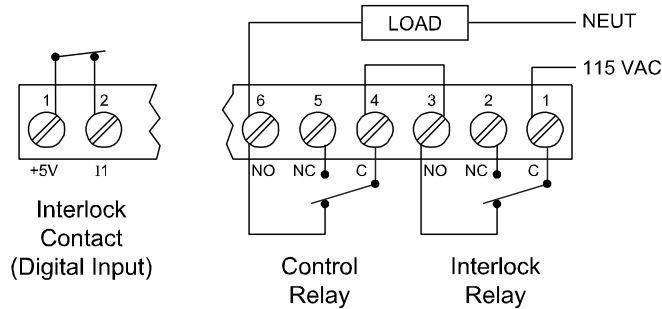

Figure 14. Interlock Connections

Analog Input Signal Connections

Analog input signal connections are made to a nine-terminal connector labeled SIGNAL on the back of the scanner. The COM (common) terminals are the return for the 4-20 mA and the ±10 V input signals. The two COM terminals connect to the same common return, and are not isolated.

Current and Voltage Connections

The following figures show examples of current and voltage connections. There are no switches or jumpers to set up for current and voltage inputs. Setup and programming is performed through the front panel buttons.

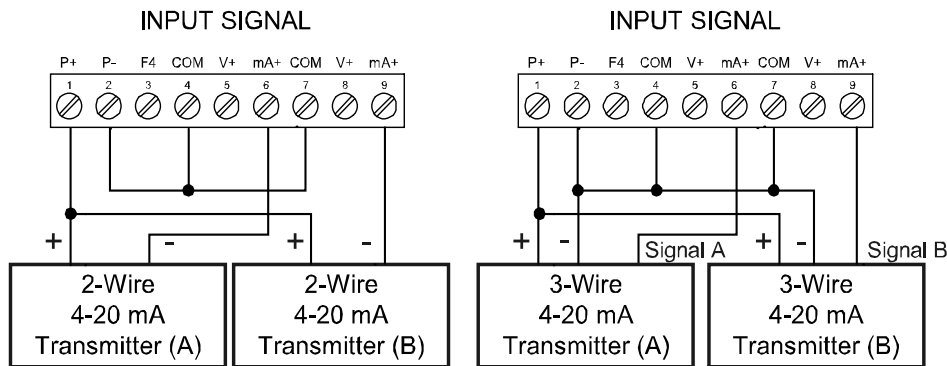

Figure 15. Transmitters Powered by Internal Supply

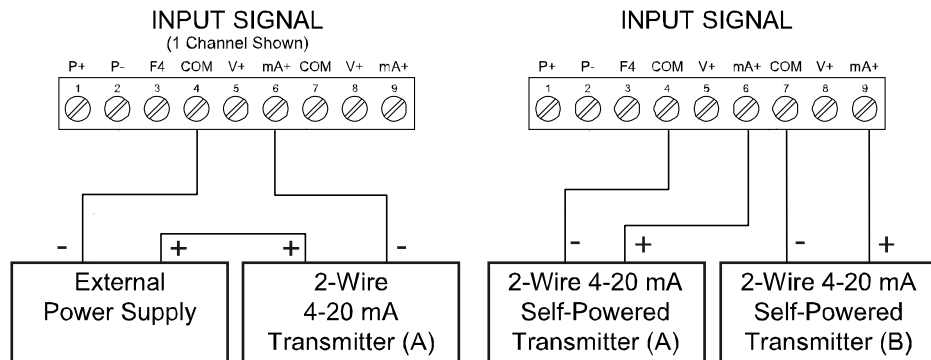

Figure 16. Transmitter Powered by Ext. Supply or Self-Powered

The current input is protected against current overload by a resettable fuse. The display may or may not show a fault condition depending on the nature of the overload. The fuse limits the current to a safe level when it detects a fault condition, and automatically resets itself when the fault condition is removed.

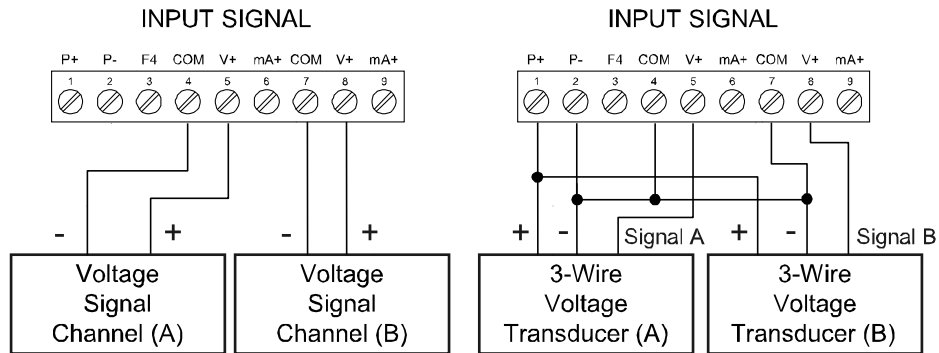

Figure 17. Voltage Input Connections

The scanner is capable of accepting any voltage from -10 VDC to +10 VDC.

Digital I/O Connections

The ProtEX-MAX has a 10 position terminal block for connecting digital inputs and outputs.

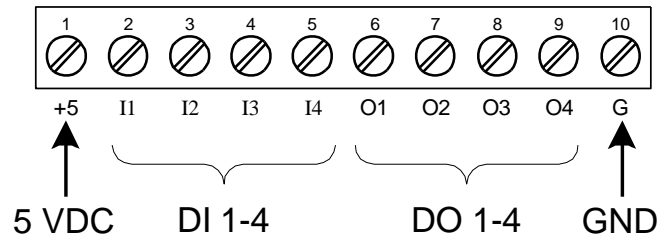



Figure 18: Digital I/O Connections

 NOTICE	<p>The onboard digital inputs (1-4) are configured at the factory to function identically to the front panel pushbuttons (Menu, F1, F2, & F3) in order to work with the SafeTouch buttons. Changing the programming of the digital inputs will affect the function of the SafeTouch buttons.</p> <p>If you wish to change the behavior of the digital inputs, re-assign F1-F3 to the desired function, then change the corresponding digital input to match.</p>
 WARNING	<p>Observe all safety regulations. Electrical wiring should be performed in accordance with all agency requirements and applicable national, state, and local codes to prevent damage to the meter and ensure personnel safety.</p>

External Switch Contacts

The ProtEX-MAX includes 4 digital inputs. These digital inputs are preconfigured at the factory to function as external contacts to duplicate the front button functions of the instrument. The factory configuration uses the following corresponding digital input terminals for external switch contacts.

Digital Input Connection	Factory Default Function
I1	MENU
I2	RIGHT arrow
I3	UP arrow
I4	ENTER arrow

See Digital Inputs & Outputs in the Specification on page 9 for details on the digital inputs.

 NOTICE	<p>The digital inputs are configured at the factory to function identically to the front panel pushbuttons in order to work with the SafeTouch buttons. Changing the programming of the digital inputs will affect the function of the SafeTouch buttons.</p>
--	---

Setup and Programming

The analog inputs of the scanner are factory calibrated prior to shipment to read in milliamps and volts, depending on the input selection. The calibration equipment is traceable to NIST standards.

Overview

There are no jumpers to set for the meter input selection.

Setup and programming may be done through the infrared through-glass SafeTouch buttons, or using the mechanical buttons when uncovered. There is a slide switch located on the connector board. This is used to enable or disable SafeTouch Buttons.

After power and input signal connections have been completed and verified, apply power to the meter.

SafeTouch® Buttons

The ProtEX-MAX is equipped with four sensors that operate as through-glass buttons so that it can be programmed and operated without removing the cover (and exposing the electronics) in a hazardous area.

These buttons can be disabled for security by selecting DISABLE on the switch labeled NO-CONTACT BUTTONS located on the connector board.

To actuate a button, press one finger to the glass directly over the marked button area. Then retract finger more than three inches from the glass before pressing the next button. When the cover is removed, the four mechanical buttons located next to the sensors are used. The sensors are disabled when a mechanical button is pressed and will automatically be re-enabled after 60 seconds of inactivity.

The SafeTouch Buttons are designed to filter normal levels of ambient interference and to protect against false triggering, however, it is recommended that the SafeTouch Buttons be disabled (slide switch to LOCK) if there is an infrared interference source in line-of-sight to the display.

The SafeTouch Buttons are configured by default to duplicate the function of the front panel mechanical pushbuttons associated with the integrated meter. The symbols by each SafeTouch button correspond to a mechanical button as shown in the table on the next page.











SafeTouch Button Tips:

- To the extent possible, install the display facing away from sunlight, windows, reflective objects and any sources of infrared interference.
- Keep the glass window clean.
- Tighten the cover securely.
- Use a password to prevent tampering.

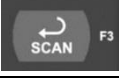

Take caution when cleaning the window glass as it may result in unintentional SafeTouch button events. Only clean the ProtEX-MAX when the system is safely shut down, and inspect the ProtEX-MAX for proper configuration prior to system restart.

Front Panel Buttons and Status LED Indicators

Button Symbol/LED	Description	LED	Status
 	Menu	1-8	Alarm 1-8 indicator
 	PREV/Right arrow/F1	1-8 M	Flashing: Relay in manual control mode
 	NEXT/Up arrow/F2	/8 /16	Displays PV to nearest 1/8 th or 1/16 th of an inch
 	SCAN/Enter/F3	1-4	Flashing: Relay interlock switch open
PREV	Go to previous PV	F	Communications Fault Condition
NEXT	Go to next PV	 PAUSE	Press SCAN to pause scanning
 STOP	Stop scan on alarm	 PLAY	Press SCAN to resume scanning
<i>Notes: F4 is a digital input.</i>		<i>Note: LEDs for relays in manual mode flash with the "M" LED every 10 seconds.</i>	

- Press the Menu button to enter or exit the Programming Mode at any time.
- Press the Right arrow button to move to the next digit during digit or decimal point programming.
- Press the Up arrow button to scroll through the menus, decimal point, or to increment a digit.
- Press the Enter button to access a menu or to accept a setting.
- Press and hold the Menu button for three seconds to access the advanced features of the scanner.
- Press the SCAN/Enter button once to pause scanning (Pause LED flashes), then press the SCAN/Enter button again to resume scanning (Play LED turns on).
- Press NEXT to go to the next PV; auto scan resumes after 10 seconds of inactivity.
- Press PREV to go to the previous PV; auto scan resumes after 10 seconds of inactivity.

ScanView Software

The meter can also be programmed using the PC-based ScanView software included with the meter. This software is can be installed on any Microsoft® Windows® (XP/Vista/7/8/10) computer by connecting to the meter's onboard USB. The meter is powered by the USB connection, so there is no need to wire anything prior to programming the meter, though USB is intended only for meter configuration.

ScanView Installation

1. Connect one end of the provided USB cable to the meter and the other end to the computer. The computer will automatically install the driver software it needs to talk to the meter. **Only one meter may be connected at a time. Attaching multiple meters will cause a conflict with the meter software.**

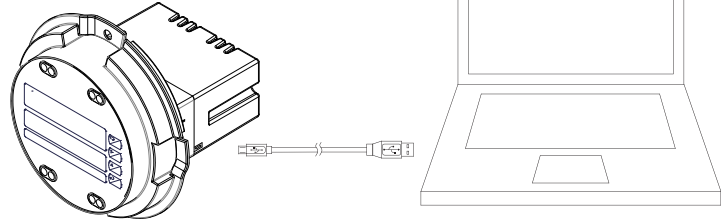

2. Once the driver is installed, an AutoPlay dialog should appear for the drive "MSINSTAL." Click "Open folder to view files." If the computer does not display an AutoPlay dialog for the drive "MSINSTAL," you should open *My Computer* and double-click on the drive labeled "MSINSTAL."
3. Double-click on the file named "MSStart." The program will open a few windows and install two programs on your computer. Simply follow the onscreen instructions until you see one of the dialogs below. If you receive a "User Account Control" warning, click "Yes."
4. If there is an update available, click the "Update" button to install the new version. Otherwise, click "Configure" to begin programming your meter.

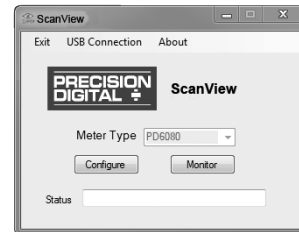
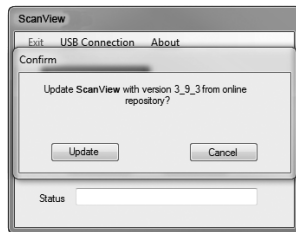
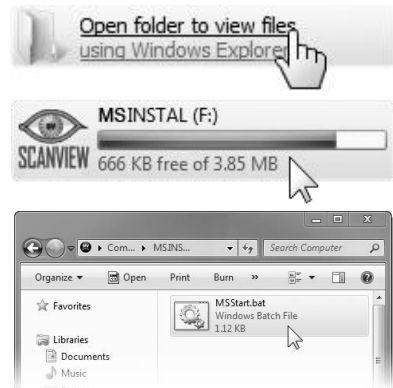

Note: If you decide to update your ScanView installation, once the installation has completed, you will be asked if you want to update the installation files located on the meter itself. This way, you will always have the most current installation version on the meter for future installs.

 Warning!	<ul style="list-style-type: none"> • Do not unplug the meter while the new installation files are being written to it. The meter will display uwrite during the process and you will receive an onscreen notification once the process is complete. • Do not disconnect and reconnect the meter rapidly. Allow at least 10 seconds from disconnection before reconnecting USB to the meter.
--	---

Monitoring and data logging for one scanner (Master mode) is available with ScanView software. All the enabled PVs and math channels may be logged to a single .csv file. The ScanView software synchronizes with the scanner in *master* mode one second after the scanner has completed a polling cycle. Additional information regarding configuration and monitoring of the meter using ScanView software is available online. Go to www.predig.com/ScanView.

Note: The poll time of the scanner must be greater than 5 seconds to prevent collisions on the bus.

Display Functions & Messages

The following table shows the main menu functions and messages in the order they appear in the menu.

Display	Parameter	Action/Setting Description
Mode	Mode	Enter <i>Mode</i> menu
Master	Master	Enter <i>Master</i> Mode
PVn	PV Number	Select PV
PV 1	PV	Select PV 1-16
Enable	Enable	Enable PV
Disable	Disable	Disable PV
Slave ID	Slave ID	Enter the unique Slave ID for each PV
Function Code	Function Code	Enter the Function Code for each PV
Register Number	Register Number	Enter the Register Number for each PV
Data Type	Data Type	Enter the Data Type for each PV
Floating Point Data Type	Floating Point Data Type	Floating Point Data Type. Select <i>Floating Point</i> as the data type to be read from the slave device.
Short Integer Data Type	Short Integer Data Type	Short Integer Data Type. Select <i>Short Integer</i> as the data type to be read from the slave device.
Long Integer Data Type	Long Integer Data Type	Long Integer Data Type. Select <i>Long Integer</i> as the data type to be read from the slave device.
Binary	Binary	Binary Data format. Select <i>Binary</i> format for Short or Long integers.
BCD	BCD	BCD Data format. Select <i>BCD</i> format for Short or Long integers.
Signed	Signed	Signed Data. Select <i>Signed</i> Binary format for Short or Long integers.
Unsigned	Unsigned	Unsigned Data. Select <i>Unsigned</i> Binary format for Short or Long integers.
Byte Order	Byte Order	Select big-endian byte order.
Byte Order	Byte Order	Select little-endian byte order.
Byte Order	Byte Order	Select byte-swapped big-endian byte order. Not available for Short integer.
Byte Order	Byte Order	Select byte-swapped little-endian byte order. Not available for Short integer.
Polling Time	Polling Time	Enter Polling Time (the time between read commands). In other words, how often the display is updated in Master mode.

Display	Parameter	Action/Setting Description
Response Time	Response Time	Enter the time allowed for a slave device to respond to a command.
Snooper	Snooper	Enter <i>Snooper</i> Mode
PVn	PV Number	Select PV
PV 1	PV	Select PV 1-16
Enable	Enable	Enable PV
Disable	Disable	Disable PV
Slave ID	Slave ID	Enter the unique Slave ID of the device to be polled by Master
Function Code	Function Code	Enter the Function Code for each PV
Function Code 03	Function Code 03	Use Function Code 03 to read slave device
Function Code 04	Function Code 04	Use Function Code 04 to read slave device
Function Code 65	Function Code 65	Use Function Code 65 to read slave device
Register Number	Register Number	Enter the Register Number for each PV
Register Number Digits	Register Number Digits	Select either 5 (x0001-x9999) or 6 (x00001-x65536) digits for the Register Number by pressing the Right Arrow in Register Number menu.
Data Type	Data Type	Enter the Data Type for each PV
Floating Point Data Type	Floating Point Data Type	Floating Point Data Type. Select <i>Floating Point</i> as the data type to be read from the slave device.
Short Integer Data Type	Short Integer Data Type	Short Integer Data Type. Select <i>Short Integer</i> as the data type to be read from the slave device.
Long Integer Data Type	Long Integer Data Type	Long Integer Data Type. Select <i>Long Integer</i> as the data type to be read from the slave device.
Binary	Binary	Binary Data. Select <i>Binary</i> format for Short or Long integers.
BCD	BCD	BCD Data. Select <i>BCD</i> format for Short or Long integers.
Signed	Signed	Signed Data. Select <i>Signed</i> Binary format for Short or Long integers.
Unsigned	Unsigned	Unsigned Data. Select <i>Unsigned</i> Binary format for Short or Long integers.
Byte Order	Byte Order	Select big-endian byte order.
Byte Order	Byte Order	Select little-endian byte order.

Display	Parameter	Action/Setting Description
24 13	Byte Order	Select byte-swapped big-endian byte order. Not available for Short.
34 12	Byte Order	Select byte-swapped little-endian byte order. Not available for Short.
τ-rESP	Response Time	Enter the time allowed for a slave device to respond to a command.
SLAVE	Slave	Enter Slave Mode
dRtR	Data Type	Enter the Data Type for each PV
FLoRt	Floating Point Data Type	Floating Point Data Type. Select <i>Floating Point</i> as the data type to be read from the slave device.
Short	Short Integer Data Type	Short Integer Data Type. Select <i>Short Integer</i> as the data type to be read from the slave device.
Long	Long Integer Data Type	Long Integer Data Type. Select <i>Long Integer</i> as the data type to be read from the slave device.
binary	Binary	Binary Data. Select <i>Binary</i> format for Short or Long integers.
bcd	BCD	BCD Data. Select <i>BCD</i> format for Short or Long integers.
signed	Signed	Signed Data. Select <i>Signed Binary</i> format for Short or Long integers.
unsigned	Unsigned	Unsigned Data. Select <i>Unsigned Binary</i> format for Short or Long integers.
1234	Byte Order	Select big-endian byte order.
432 1	Byte Order	Select little-endian byte order.
24 13	Byte Order	Select byte-swapped big-endian byte order. Not available for Short integer.
34 12	Byte Order	Select byte-swapped little-endian byte order. Not available for Short integer.
τ-rESP	Response Time	Enter the time allowed for a slave device to respond to a command.
SEtUP	Setup	Enter Setup menu
PV	Process Variable	Enter PV Setup menu
PV 1	PV	Select PV 1-16
TAG	Tag	Tag
units	Units	Units
Format	Format	Format (Decimal, Eighths, or Sixteenths of an Inch)
dEc	Decimal	Decimal Format

Display	Parameter	Action/Setting Description
Flt in 8	Eighths	Eighth Inch Format
Flt in 16	Sixteenths	Sixteenth Inch Format
dEcPt	Decimal Point	Decimal Point menu
d .5P.dP	Display Decimal Point	Set the decimal point position for the display. This is independent from float decimal point.
FLoat.dP	Floating Decimal Point	Floating Decimal Point. Select the decimal point for the expected floating point data.
SCALE	Scale PV	Scale PV
inP 1	Input 1	Calibrate input 1 signal or program input 1 value
d .5 1	Display 1	Program display 1 value
inP 2	Input 2	Calibrate input 2 signal or program input 2 value (up to 32 points)
d .5 2	Display 2	Program display 2 value (up to 32 points)
d5PLAY	Display	Enter Display Setup menu
L inE 1	Display Line 1	Top Display
d PV	Display PV	Display PVs 1-16
d Ch-C	Display C Channel	Display Math Channels C1-C4
PV unit	Display PV & Units	Display PV & Units
Tag.PVn	Display Tag, PV Number	Display Tag & PV Number selected
Tag.PVn.u	Display Tag, PV# & Units	Display Tag, PV Number selected, & Units
Ch-C	Display C & Units	Display C1-C4 & Units
Tag. C. u	Display Tag, C, & Units	Display Tag, C1-C4 & Units
dSEt 1	Display Set Points 1-8	Display Set Points 1-8
Max-PV	Display Max PV 1-16	Display Maximum value for each enabled PV1-16
Min-PV	Display Min PV 1-16	Display Minimum value for each enabled PV1-16
Max-Ch	Display Max Ch C1-C4	Display Maximum for math channels C1-C4
Min-Ch	Display Min Ch C1-C4	Display Minimum for math channels C1-C4
L inE 2	Display Line 2	Bottom Display
d TAG	Display Tag	Display Tag
d TAG.u	Display Tag & Units	Display Tag & Units
d OFF	Display off	Display Off
d- inT	Display Intensity	Display Intensity
RELAY	Relay Setup	Enter Relay Setup menu
ASSIGN	Assign Relay	Assign Relay menu
RELAY 1	Relay 1-8	Assign Relay 1-8
PV 1	PV 1-16	Map Relay to PV 1-16
Multiple-PV	Multiple PVs	Map Relay to Multiple PVs
RELAY 1	Relay 1-8	Relay 1-8

Display	Parameter	Action/Setting Description
Rct 1	Relay Action 1-8	Assign Relay Action for relays 1-8
Rcto	Automatic	Set relay for automatic reset
A-nman	Auto-manual	Set relay for auto or manual reset any time
LRLCH	Latching	Set relay for latching operation
Lt-CLR	Latching-cleared	Set relay for latching operation with manual reset only after alarm condition has cleared
RLTErn	Alternate	Set relay for pump alternation control
SRn PL	Sample	Set relay for sample time trigger control
OFF	Off	Turn relay off
FR LSF	Fail-safe	Enter Fail-safe menu
FLS 1	Fail-safe 1	Set relay 1-4 fail-safe operation
on	On	Enable fail-safe operation
off	Off	Disable fail-safe operation
dELAY	Delay	Enter relay Time Delay menu
dLY 1*	Delay 1*	*Enter relay 1-4 time delay setup
On 1	On 1	Set relay 1 On time delay
OFF 1	Off 1	Set relay 1 Off time delay
brERH	Break	Set relay condition if communication break detected
no Rct	No action	Ignore break condition. No change in relay state when Communications Break detected.
On	On	Relay goes to alarm condition when break detected. Relay turns on when Communications Break detected.
OFF	Off	Relay goes to non-alarm condition when break detected. Relay turns off when Communications Break detected.
Rout	Analog output	Enter the Analog Output scaling menu
AOut 1*	Aout channel	Analog Output source channel (*1-3)

Display	Parameter	Action/Setting Description
d 1 1	Display 1	Program the first Display value for the Analog Output.
Out 1	Output 1	Program the first Output value that corresponds to the Display 1 value for the Analog Output. (e.g. 4.000 mA).
d 1 2	Display 2	Program the second Display value for the Analog Output.
Out 2	Output 2	Program the second Output value that corresponds to the Display 2 value for the Analog Output. (e.g. 4.000 mA). (e.g. 20.000 mA)
Ser iRL	Serial	Enter Serial menu
Scan ID	Scan ID	Enter Scan ID of the meter being polled (1-247)
baud	Baud Rate	Select Baud Rate (Choices: 300/600/1200/2400/4800/9600/19,200) (Must match that of other devices)
tr dLY	Transmit Delay	Enter Transmit Delay (Master's delay must be greater than Snooper or slave devices)
Par iLY	Parity	Select Parity (Even, Odd, None 1-Stop, or None 2-Stop) (Must match that of other devices)
t-byt	Byte-to-byte Timeout	Enter the timeout value allowed between received bytes. (This is used to fix communication problems with slow devices).
PASS	Password	Enter the Password menu
PASS 1	Password 1	Set or enter Password 1
PASS 2	Password 2	Set or enter Password 2
PASS 3	Password 3	Set or enter Password 3
unLoc	Unlocked	Program password to lock scanner
Locd	Locked	Enter password to unlock scanner
999999 -999999	Flashing	Over/under range condition

Menu Navigation Tip

- The Up arrow scrolls through the sub-menus within a menu, after the last item it returns to the top menu. Press Enter to step into the menu again or press Up arrow to move to the next menu. Note: There are some exceptions (e.g. PV - Enable - - Data type ▲ Next PV).
- Press Menu to exit programming at any time.

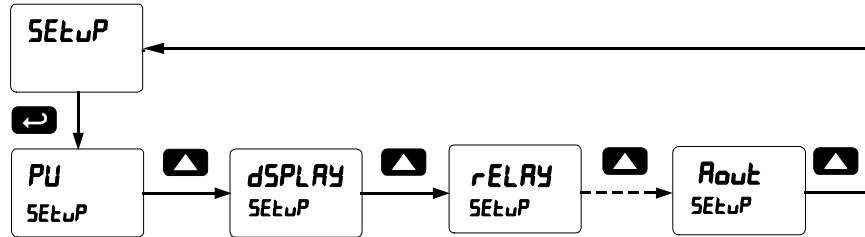

Setting Numeric Values

The numeric values are set using the Right and Up arrow buttons. Press the Right arrow to select the next digit and the Up arrow to increment the digit's value. The digit being changed is displayed brighter than the rest. Press and hold the Up arrow to auto-increment the display value. Press the Enter button, at any time, to accept a setting or the Menu button to exit without saving changes.

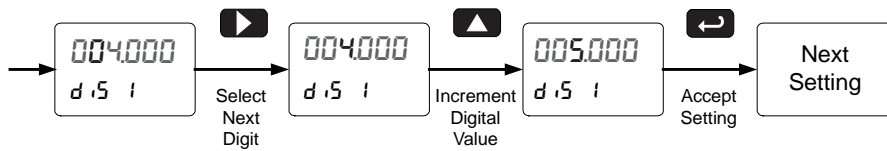

Main Menu

The main menu consists of the most commonly used functions: *Mode*, *Setup*, *Serial*, and *Password*.

- Press Menu button to enter Scanner Programming
- Press Up arrow button to scroll through the menus
- Press Menu, at any time, to exit and return to Run Mode
- Changes to the settings are saved to memory only after pressing Enter
- The display moves to the next menu every time a setting is accepted by pressing Enter

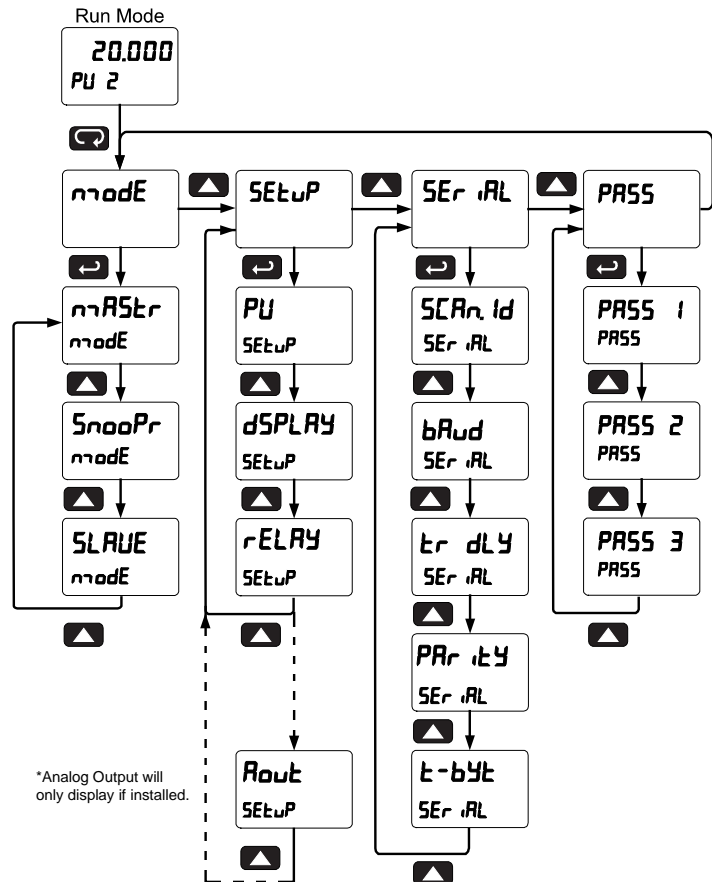

*Analog Output will only display if installed.

Serial Communications (SErIAL)

The scanner is equipped with RS-485 Modbus RTU serial communications.

The *Serial* menu is used for programming the Scanner ID, Baud Rate, Transmit Delay, Parity, and Byte-to-Byte Timeout parameters.

The meter may be connected to a PC for initial configuration via the onboard micro USB connection. For ongoing digital communications with a computer or other data terminal equipment, an RS-232, or RS-485 converter is required; see *Ordering Information* on page 6 for details.



Warning! *Do not connect any equipment other than Precision Digital's expansion modules, cables, or scanners to the RJ45 M-LINK connector. Otherwise damage will occur to the equipment and the scanner.*

When using more than one scanner in a multi-drop mode, each scanner must be provided with its own unique address. The scanner address (Scan ID) may be programmed between 1 and 247.

The transmit delay may be set between 0 and 4999 ms; this value must be less than (Poll Time/# of PVs).

The parity can be set to even, odd, or none with 1 or 2 stop bits.

Changes made to the Serial menu are initialized after exiting the Serial menu.

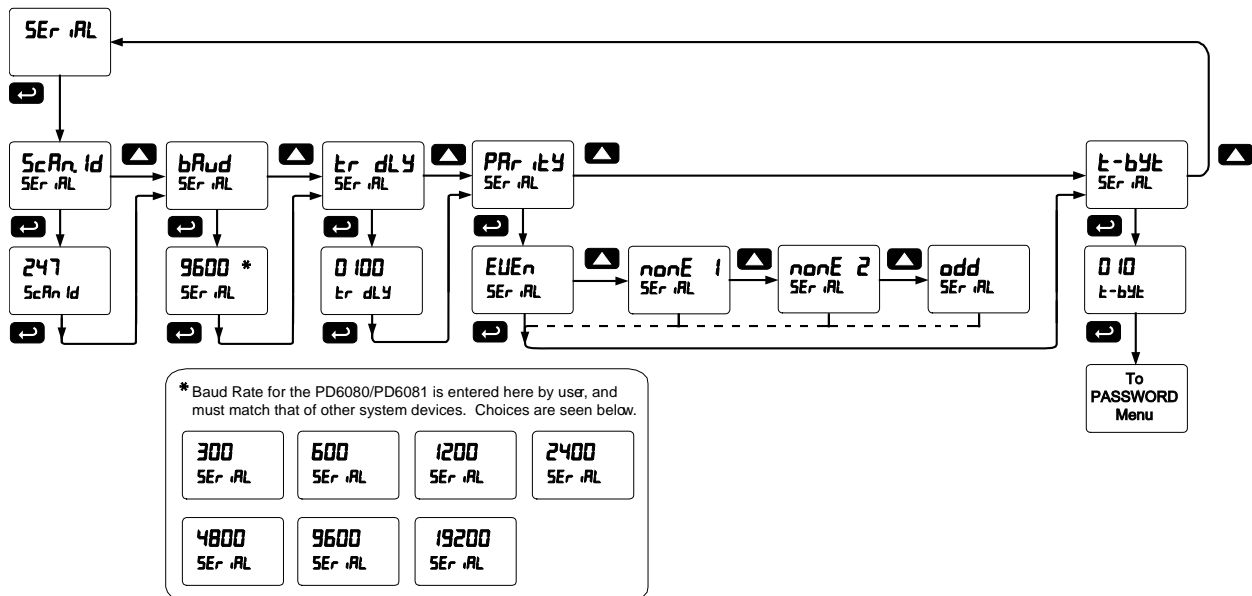

When setting up the scanner to run on a Modbus system, the devices must be programmed with matching Baud Rate and Parity. Failure to match up the network devices' parameters may result in communication breaks.

Notes:

1. The byte-to-byte timeout setting may be adjusted to fix communication errors with slow devices.
2. The Transmit Delay of the Master must be greater than the Snooper or the slave devices being polled.

Scanner Mode Selection

Operating Modes (מִדָּמָה)

The *Mode* menu is used to select how the scanner is to function:

1. **Master:** Reads a slave device, scales the data from it, displays the result, and operates the relays and 4-20 mA output. The Master polls from 1 to 16 process variables from 1 to 16 slave devices. The Master processes and displays PV1 through PV16 and alternately displays the variables being polled.
2. **Snooper:** Listens to the Modbus traffic and picks up a specific register or registers being polled by a Master device from a specific slave device and processes the data being read.
3. **Slave:** Read and controlled by a master device (PLC, DCS, etc). The data sent to it by the master is scaled, displayed, and used to operate the relays and 4-20 mA output.

The Master mode requires additional parameter selection to specify how the slave device is to be read and how to interpret the data.

Press **Menu** to enter Scanner Programming. Press the **Enter** button to access any menu or press **Up** arrow button to scroll through choices. Press the **Menu** button to exit at any time and return to Run mode.

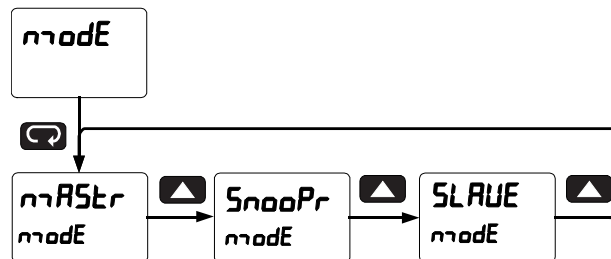

How to Enable Process Variables (PVs)

In Master or Snooper Mode, navigate to the *PV Number* menu and press ENTER. From there, the user can scroll through all of the sixteen available PVs. In order to enable a specific PV, simply press ENTER to access the desired PV, then scroll to ENABLE and press ENTER (Follow the same course of action for disabling PVs).

Enter the Slave ID of the device being polled by the Master, followed by the Function Code, Register Number, Data Type, and Byte Order. Analog input channels must be assigned a Slave ID corresponding to the input to be read as indicated here: Ch A = 256 (mA) or 257 (V), Ch B = 258 (mA) or 259 (V).

Once the desired PVs are enabled, navigate to the *Setup* menu and enter the PV Setup in order to select the PV tag, units, format, and decimal point parameters, as well as to scale the PVs.

Once the user has scaled the final PV, the scanner automatically goes to the *Display Setup* menu to access line 1 and 2 display assignments.

By default, display line 1 is assigned to *Display PV (d pv)* and line 2 to display the *Tag (d tag)* for the corresponding PV.

It is possible to display PVs & Tags on line 1 and 2 simultaneously by selecting *Tag & PV Number (tag.pvn)*. Display line 1 is setup by default to display PV & tag for PV1, 3, 5, 7; while line 2 is setup by default to display PV & tag 2, 4, 6, 8. These can be changed by the user to display any or all PVs. Program either display line 1 or 2 to show the desired parameters and press ENTER. See page 39 for details.

Master Mode (mAStr)

The Master mode contains the *PV Number*, *Poll Time*, and *Response Timeout* menus.

PV Number: Enable/disable PVs, select slave ID, function code, register number, data type & byte order.

Poll Time: Enter the time interval to poll the slave devices selected.

Response timeout: Enter the time interval to wait after three polls before reporting it as a Communications Break.

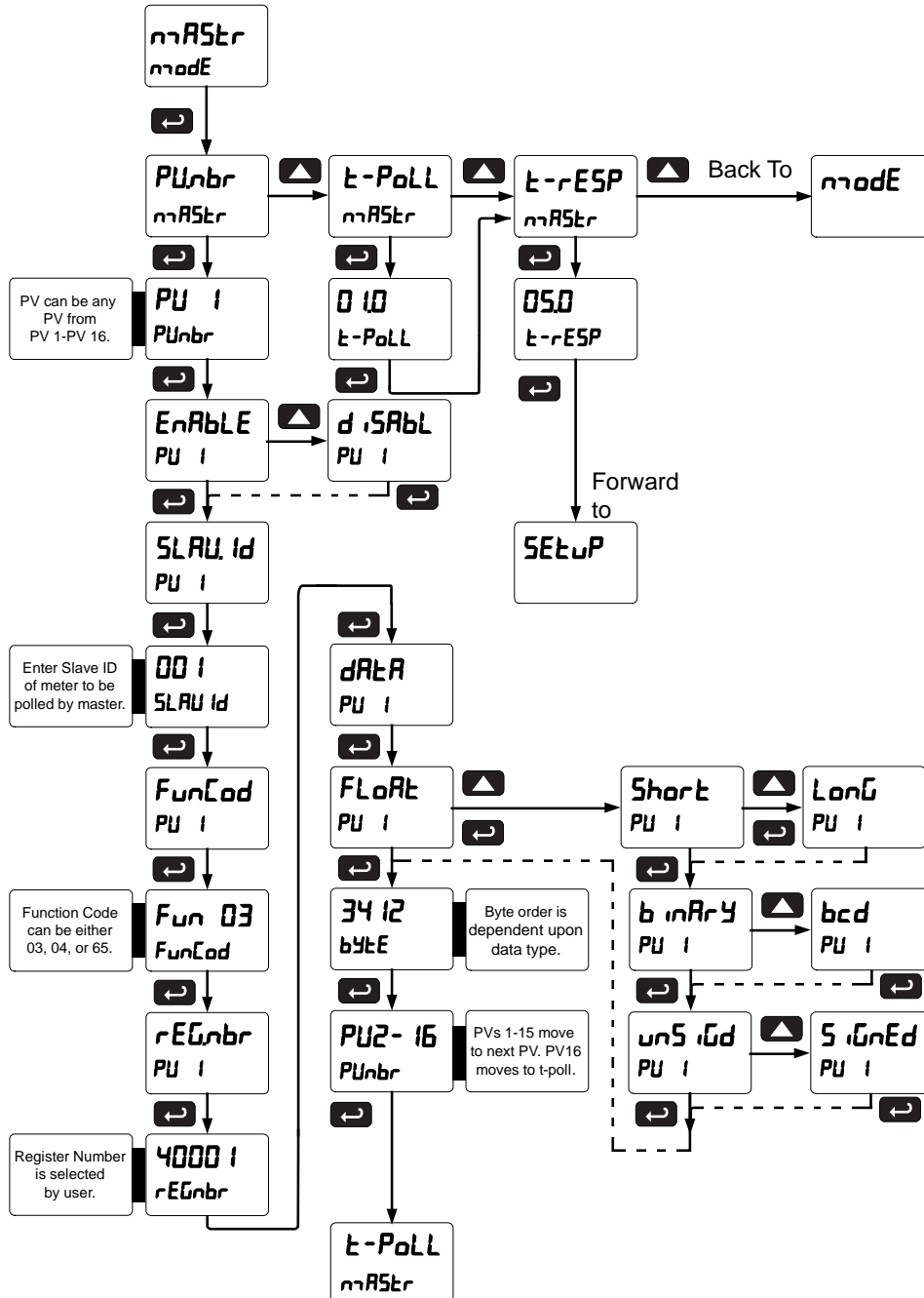

Snooper Mode (SnooPr)

The Snooper mode is used to listen to data being transmitted on the bus. Multiple Snoopers can be connected to the RS-485 bus and display any process variable. The same process variable can be displayed in multiple locations. Use the menu below to configure Snooper Mode parameters.

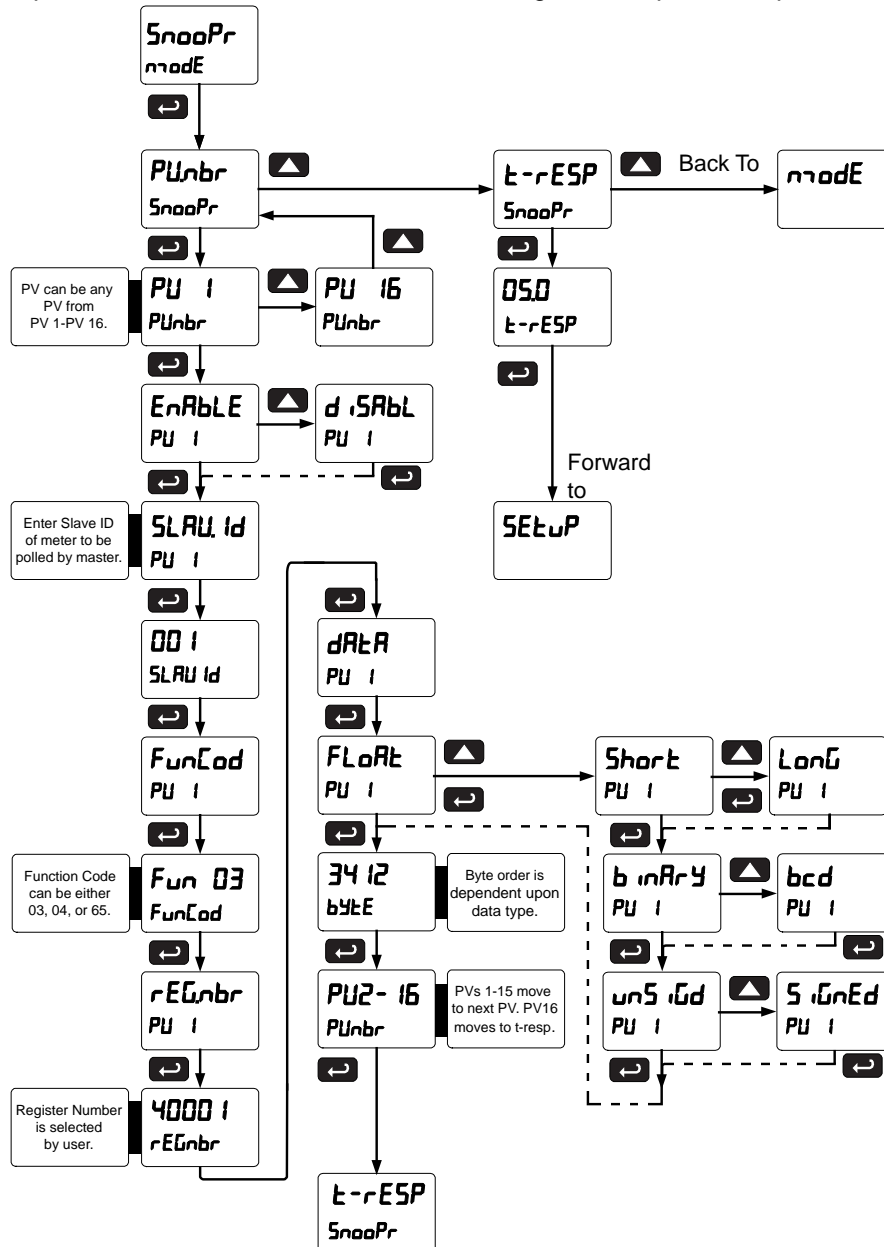

Notes:

1. To minimize the possibility of communication errors and communication break conditions, use a poll time of 5 seconds or more with slow baud rates (e.g. 4800 bps or less).
2. The response time for scanners set up for Snooper mode must be greater than the Master's poll time. This setting corresponds to the time window during which the Snooper listens to the bus for a reply by the slave device being polled by the master device. As soon as the Snooper detects a new reply on the bus, the display is updated. If there is no reply within the response time setting, the Snooper goes into communications break condition.

How to Select 5 or 6-Digit Registers

In Master or Snooper Mode, it is possible to select either a five-digit or a six-digit Register Number. Once the operator has enabled a PV, entered a Slave ID, and chosen a Function Code, the scanner will arrive at the Register Number menu (**rEGnbr**). Press the Right arrow to display and then the Up arrow to change the setting for the number of digits used for the Register Number (**5 d iG** or **6 d iG**), then press ENTER.

Notes:

1. If Function Code 03 is selected, the Register Number defaults to 40001; if Function Code 04 is selected, the Register Number defaults to 30001.
2. Default Data Type is Float
3. Default Slave ID for PV1=001, for PV2=002, for PV3=003, etc.

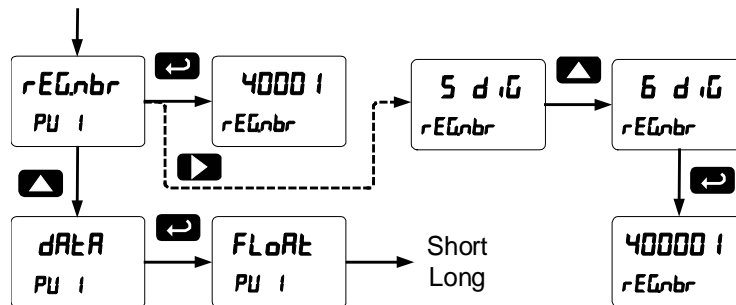

The Master ignores the decimal point setting for slave devices that specify a Short or Long integer. For example, a slave that is displaying 12.34 is read as 1,234. Floating point data may or may not utilize the decimal point. Refer to the slave's operating manual to make sure.

The Register Number range is based on the Function Code and the number of digits selected. See the following table:

Function Code	5 Digit	6 Digit
03	40001 – 49999	400001 – 465536
04	30001 – 39999	300001 – 365536
65	65001-65999	N/A

Slave Mode (SLAVE)

The Slave mode is capable of accepting Short, Long, and Float data types. Refer to the Modbus Register Tables at www.predig.com for details of all the predefined parameters. Follow the menu below to navigate and set all parameters for Slave Mode.

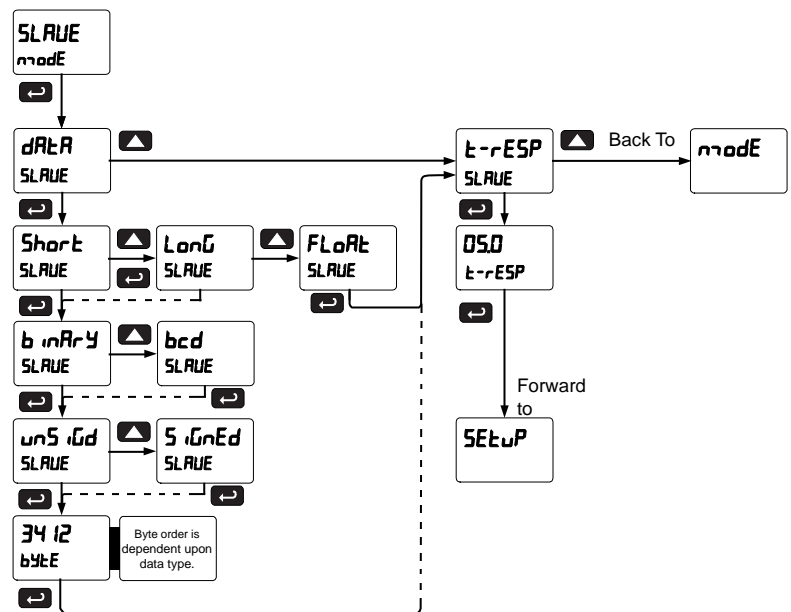

Setting Up the Scanner (SEtUP)

The *Setup* menu is used to select:

1. PV Setup
 - a. PV Tags
 - b. PV Units
 - c. Format: Decimal point or Feet & Inches
 - d. Decimal Point
 - e. Scale input data
2. Display assignment & Intensity
3. Relay assignment and operation
4. 4-20 mA analog output scaling

Press the Menu button to exit at any time.

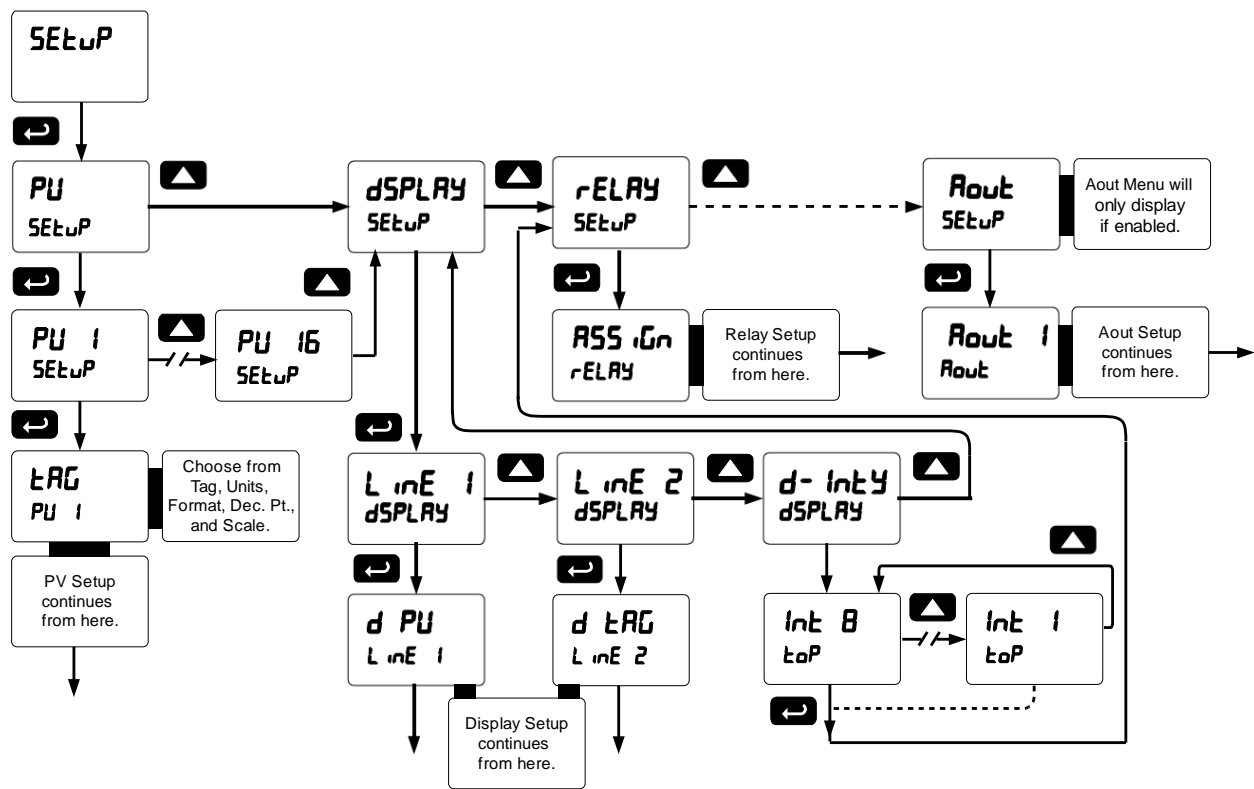

Setting Up the Process Variables (PVs) (PU SEtUP)

Enter the *PV Setup* menu to set up all the criteria associated with each enabled PV. Once you have selected the desired PV, you can select parameters for each. These include tag, units, format, display decimal point, float decimal point (resolution), and scaling of the input data.

Note: PV1 and PV2 can have multiple points for linearization. Only two points are available for all other PVs and for either the Square Root or Programmable Exponent functions.

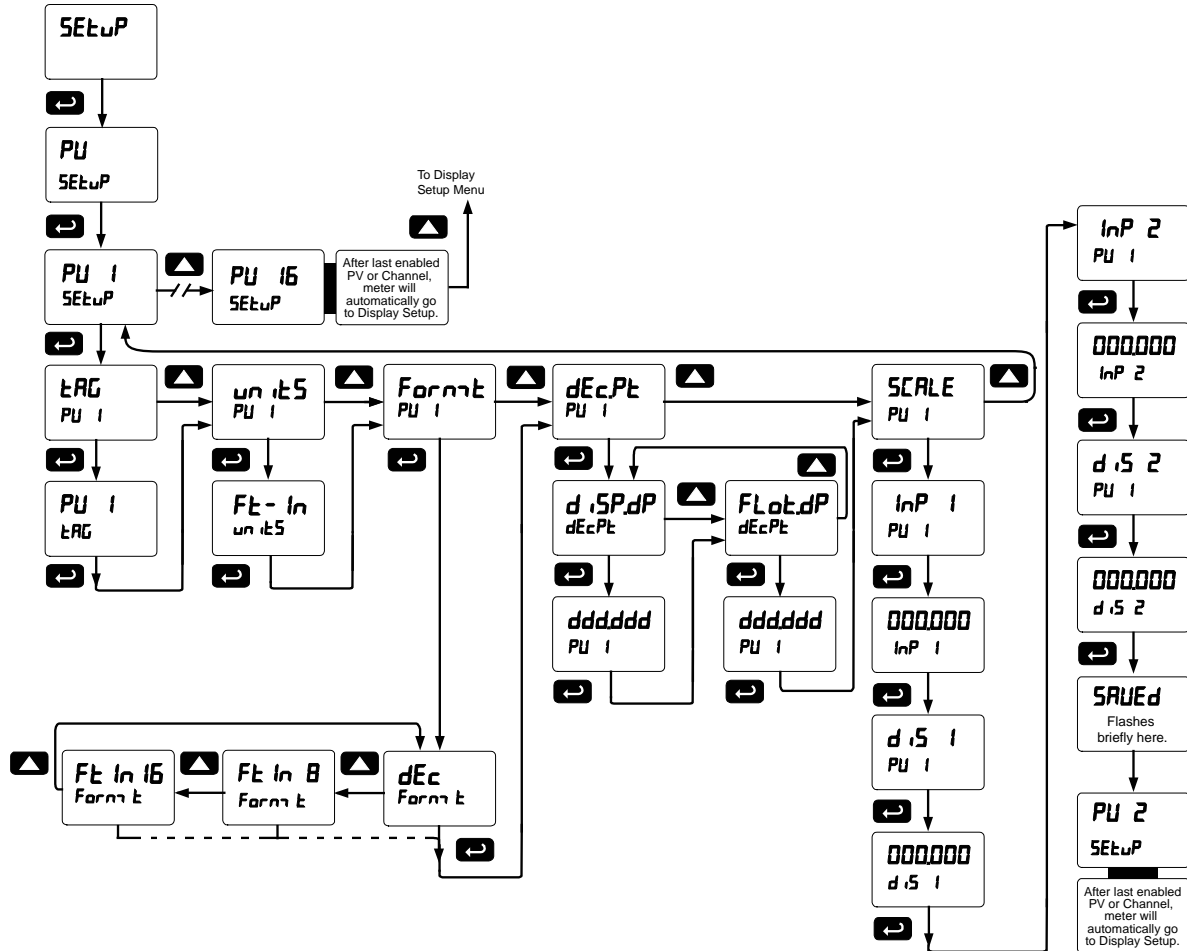

Setting the Display Decimal Point (disp.dp)

Decimal point may be set one to five decimal places or with no decimal point at all. Pressing the **Up** arrow moves the decimal point one place to the right until no decimal point is displayed, and then it moves to the leftmost position. The decimal point is programmable only for the Display Value.

Setting the Float Decimal Point (FLot.dP)

If floating point data type is selected, select the number of decimals to correspond to the expected floating point data; the numbers to right of the LSD will be ignored by the scanner.

Example:

If you have a number such as 12.3456, you have to tell the scanner how many digits to the right are of interest to you. In this case selecting 4 places will make use of all the digits. For most applications the display decimal point will be set accordingly (*i.e.* 4 places).

If 2 decimal places are selected, the number 12.3456 is displayed as 12.35; notice that the number is rounded up.

Scaling the PV Display Values (SCALE)

The data that the scanner receives can be scaled to display in engineering units. Input 1 must be less than Input 2, Input 2 must be less than Input 3, etc. (known as monotonic values). Press **Enter** to save the changes or **Menu** to exit without saving. When the Linear function is selected for PV1 & PV2, up to 32 points may be programmed to handle non-linear data. Only two points are available for all other PVs and for either the Square Root or Programmable Exponent functions. Round Horizontal Tanks are scaled using the length and diameter of the tank.

Scale Menu

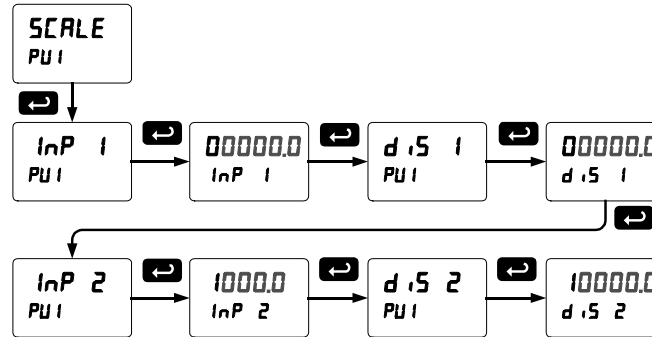

The display will show **Error** if the scaling or calibration process is unsuccessful. Undesired operation may occur if the error is not corrected. Correct the error by either changing one of the inputs in question or changing the number of points to exclude an erroneous input point.

Note 1: For Feet & Inches Display format, the display values will be in the format 99 FT 11 IN 15 /16th or 8th. Make the left digit for inches and 16th blank if the value is less than 10. Example: 50 Feet, 9 Inches, and 8/16 will be displayed as 50 FT _9 IN _8 16th instead of 50 FT 09 IN 08 /16th.

Note 2: Scaling Short and Long input values (input 1, input 2, etc.) should be done without the decimal point.

Multi-Point Linearization (L inERR)

The scanner is set up at the factory for 2-point linear scaling. Up to 32 linearization points may be selected for PV1 and PV2. All other PVs have two linearization points available. See page 63 for details.

Setting Up the Displays (*d5PLAY SEtUP*)

Display Line 1 Parameters (*L nE 1 d5PLAY*)

The top display (*L nE 1*) can be programmed to display any of the following:

Display	Parameter	Setting Description
<i>d PV</i>	<i>Display PV</i>	Display PVs 1-16
<i>d Ch-C</i>	<i>Display C Channel</i>	Display Math Channels C1-C4
<i>PVn U</i>	<i>Display PV & Units</i>	Display PV & Units
<i>tPVn</i>	<i>Display Tag, PV Number</i>	Display Tag & PV Number selected
<i>tPVnU</i>	<i>Display Tag, PV# & Units</i>	Display Tag, PV Number selected, & Units
<i>CU</i>	<i>Display C & Units</i>	Display C1-C4 & Units
<i>t. C. U</i>	<i>Display Tag, C, &</i>	Display Tag, C1-C4 &

Display	Parameter	Setting Description
	<i>Units</i>	Units
<i>dSEt 1</i>	<i>Display Set Points 1-8</i>	Display Set Points 1-8
<i>H 1-PV</i>	<i>Display Max PV 1-16</i>	Display Maximum value for each enabled PV1-16
<i>Lo-PV</i>	<i>Display Min PV 1-16</i>	Display Minimum value for each enabled PV1-16
<i>H 1-C</i>	<i>Display Max Ch C1-C4</i>	Display Maximum for math channels C1-C4
<i>Lo-C</i>	<i>Display Min Ch C1-C4</i>	Display Minimum for math channels C1-C4

Display Line 2 Parameters (*L nE 2 d5PLAY*)

The bottom display (*L nE 2*) can be programmed to display any of the following:

Display	Parameter	Setting Description
<i>d PV</i>	<i>Display PV</i>	Display PVs 1-16
<i>d Ch-C</i>	<i>Display C Channel</i>	Display Math Channels C1-C4
<i>PVn U</i>	<i>Display PV & Units</i>	Display PV & Units
<i>tPVn</i>	<i>Display Tag, PV Number</i>	Display Tag & PV Number selected
<i>tPVnU</i>	<i>Display Tag, PV# & Units</i>	Display Tag, PV Number selected, & Units
<i>CU</i>	<i>Display C & Units</i>	Display C1-C4 & Units
<i>t. C. U</i>	<i>Display Tag, C, & Units</i>	Display Tag, C1-C4 & Units
<i>dSEt 1</i>	<i>Display Set Points</i>	Display Set Points 1-8

Display	Parameter	Setting Description
	<i>1-8</i>	
<i>H 1-PV</i>	<i>Display Max PV 1-16</i>	Display Maximum value for each enabled PV1-16
<i>Lo-PV</i>	<i>Display Min PV 1-16</i>	Display Minimum value for each enabled PV1-16
<i>H 1-C</i>	<i>Display Max Ch C1-C4</i>	Display Maximum for math channels C1-C4
<i>Lo-C</i>	<i>Display Min Ch C1-C4</i>	Display Minimum for math channels C1-C4
<i>d tRt</i>	<i>Display Tag</i>	Display Tag (Line 2 only)
<i>d tRtU</i>	<i>Display Tag & Units</i>	Display Tag & Units (Line 2 only)
<i>d oFF</i>	<i>Display off</i>	Display Off (Line 2 only)

Note: Toggling displays use the Scan Time for the value and 2 seconds for Tag and Units.

Display Intensity (*d- IntY*)

The scanner has eight display intensity levels to give the best performance under various lighting conditions. Select intensity 8 for outdoor applications. The default intensity setting is 8.

Display Line 1 Menu (Line 1 dSPRAY)

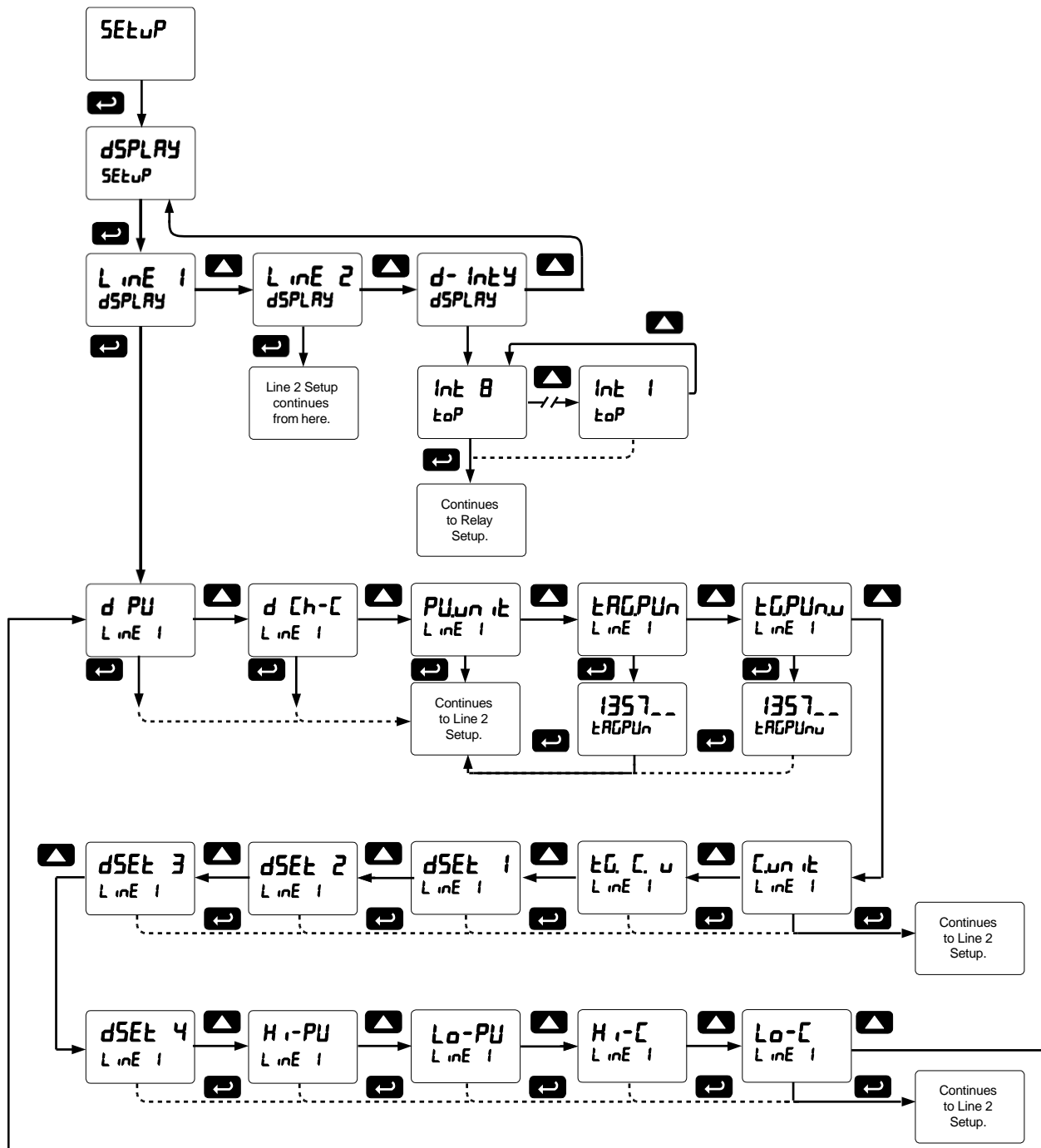

Note: For Tag-PVn and Tag-PVn-U, the default settings for PVs are 1,3,5,&7, followed by two underscores, which represent empty PVs. These all can be changed to any enabled PVs.

Display Line 2 Menu (LINE 2 dSPRAY)

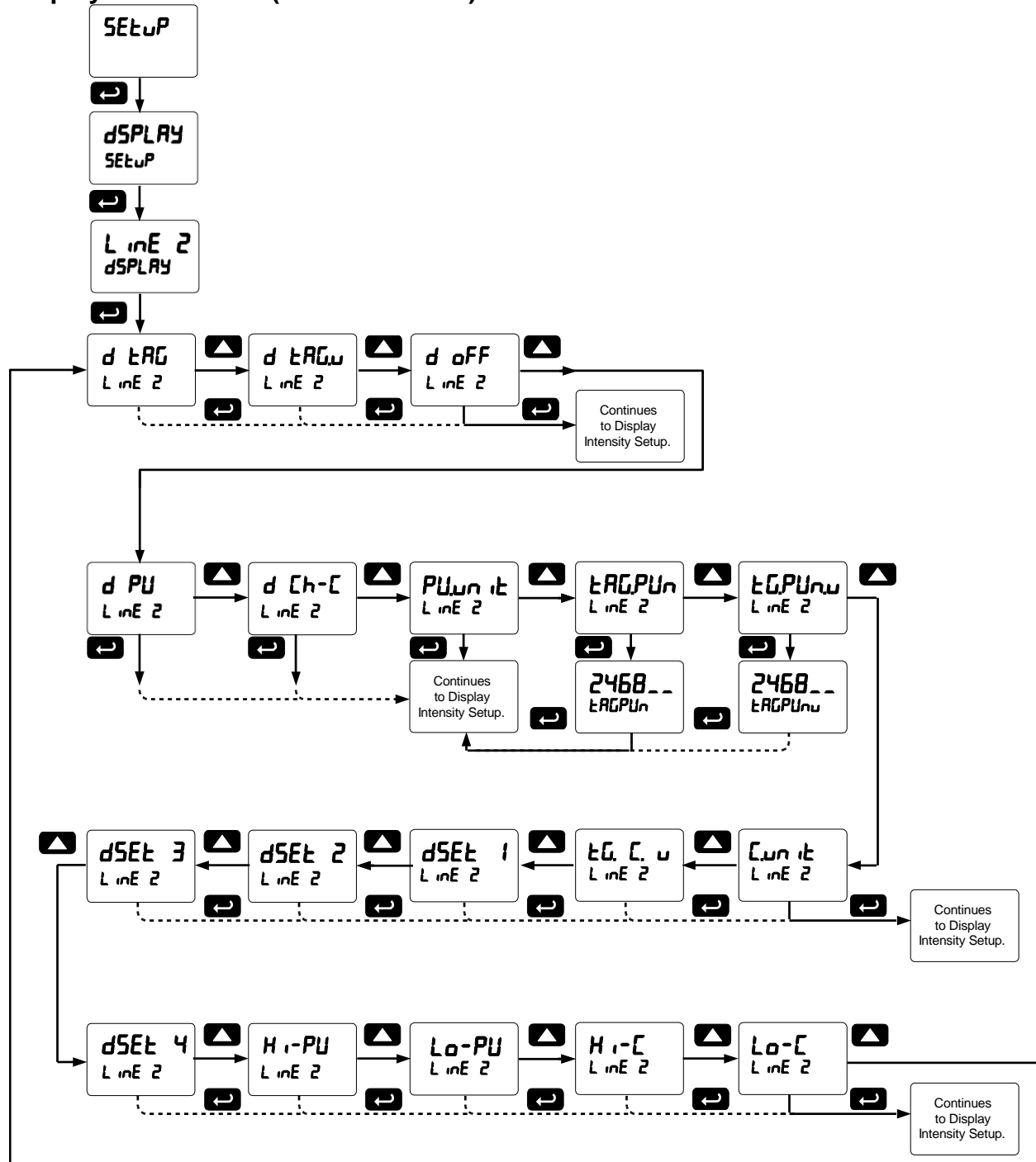

Note: For Tag-PVn and Tag-PVn-U, the default settings for PVs are 2,4,6,& 8, followed by two underscores, which represent empty PVs. These all can be changed to any enabled PVs.

Setting the Tags (TAG) & Units (UNIT)

Each PV can be setup with its own tag and units. See the flow charts on the previous pages to access the display menu to show the tag or toggling tag & units. The engineering units and custom tags can be set using the following 7-segment character set:

Display	Character	Display	Character	Display	Character	Display	Character
0	0	C	C	K	K	v	V
1	1	c	c	L	L	v v	w
2	2	d	d	m	m	X	X
3	3	E	E	n	n	Y	Y
4	4	F	F	O	O	Z	Z
5	5	G	G	o	o	-	-
6	6	g	g	P	P	/	/
7	7	H	H	q	q	[]
8	8	h	h	r	r]	[
9	9	I	I	S	S	=	=
A	A	i	i	t	t	°	Degree(<)
b	b	J	J	u	u		Space

Notes: Degree symbol represented by (<) if programming with ScanView. The letters "m" and "w" use two 7-segment LEDs each; when selected the characters to the right are shifted one position. Press and hold up arrow to auto-scroll the characters in the display.

Application Example 1

In this application we have a system consisting of (4) MTS M-Series multivariable tank level gauges connected to (2) PD6080 displaying Product Level, Interface Level, and Average Temperature. One of the Modbus Scanners is located next to the tanks and the other is located in the control room.

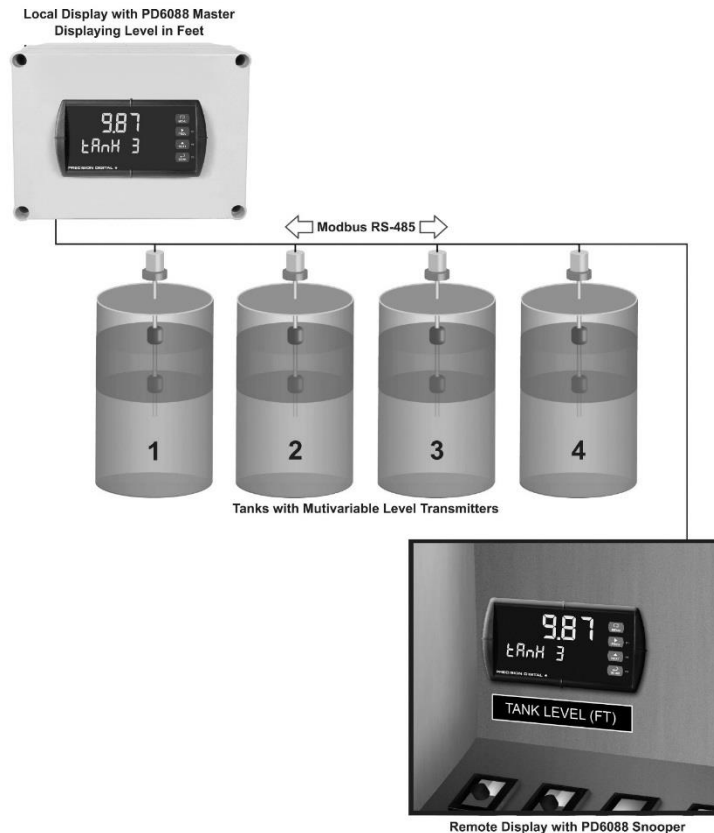

Register Numbers & Process Variables

- 30001 - Product Level
- 30003 - Interface Level
- 30017 - Average Temperature

The following table shows the system setup for the MTS M-Series gauge, one PD6080 Master, and one PD6080 Snooper:

Parameter	PD6080 Master	PD6080 Snooper	Description/Comment	Parameter	PD6080 Master	PD6080 Snooper	Description/Comment
Mode	Master	Snooper		Data Type	Long integer Binary, Signed	Long	
PV1 Slave ID	1	1		Byte Order	1234	1234	
Function Code	04	04		PV5 Slave ID	2	2	
Register PV1	30001	30001	Tank 1 Product Level	Function Code	04	04	
Data Type	Long integer Binary, Signed	Long		Register PV5	30003	30003	Tank 2 Interface
Byte Order	1234	1234		Data Type	Long integer Binary, Signed	Long	
PV2 Slave ID	1	1		Byte Order	1234	1234	
Function Code	04	04		PV6 Slave ID	2	2	
Register PV2	30003	30003	Tank 1 Interface	Function Code	04	04	
Data Type	Long integer Binary, Signed	Long		Register PV6	30017	30017	Tank 2 Average Temperature
Byte Order	1234	1234		Data Type	Long integer Binary, Signed	Long	
PV3 Slave ID	1	1		Byte Order	1234	1234	
Function Code	04	04		PV7 Slave ID	3	3	
Register PV3	30017	30017	Tank 1 Average Temperature	Function Code	04	04	
Data Type	Long integer Binary, Signed	Long		Register PV7	30001	30001	Tank 3 Product Level
Byte Order	1234	1234		Data Type	Long integer Binary, Signed	Long	
PV4 Slave ID	2	2		Byte Order	1234	1234	
Function Code	04	04		PV8 Slave ID	3	3	
Register PV4	30001	30001	Tank 2 Product Level	Function Code	04	04	

Parameter	PD6080 Master	PD6080 Snooper	Description/Comment	Parameter	PD6080 Master	PD6080 Snooper	Description/Comment
Register PV8	30003	30003	Tank 3 Interface	Data Type	Long integer Binary, Signed	Long	
Data Type	Long integer Binary, Signed	Long		Byte Order	1234	1234	
Byte Order	1234	1234		PV12 Slave ID	4	4	
PV9 Slave ID	3	3		Function Code	04	04	
Function Code	04	04		Register PV12	30017	30017	Tank 4 Average Temperature
Register PV9	30017	30017	Tank 3 Average Temperature	Data Type	Long integer Binary, Signed	Long	
Data Type	Long integer Binary, Signed	Long		Byte Order	1234	1234	
Byte Order	1234	1234		Scanner ID	246	245	
PV10 Slave ID	4	4		Polling Time	5.0 sec	N/A	
Function Code	04	04		Slave Response Timeout	10.0 sec	10.0 sec	
Register PV10	30001	30001	Tank 4 Product Level	Baud	4800	4800	
Data Type	Long integer Binary, Signed	Long		Parity	None 1	None 1	1 stop bit
Byte Order	1234	1234		Byte-to-Byte Timeout	0.01 sec	0.01 sec	
PV11 Slave ID	4	4		Decimal point	3 places	3 places	
Function Code	04	04		Input 1	000000	000000	Scaling for Level & Interface
Register PV11	30003	30003	Tank 4 Interface	Display 1	000000	000000	
				Input 2	999999	999999	0.001 inch resolution
				Display 2	83.333	83.333	Feet

Application Example 2

In this application we have a system consisting of (4) MTS M-Series multivariable tank level gauges connected to (2) PD6081s displaying Product Level, Interface Level, and Average Temperature.

One of the Modbus Scanners is located next to the tanks and the other is located in the control room. The display readout is shown in sixteenths of an inch.

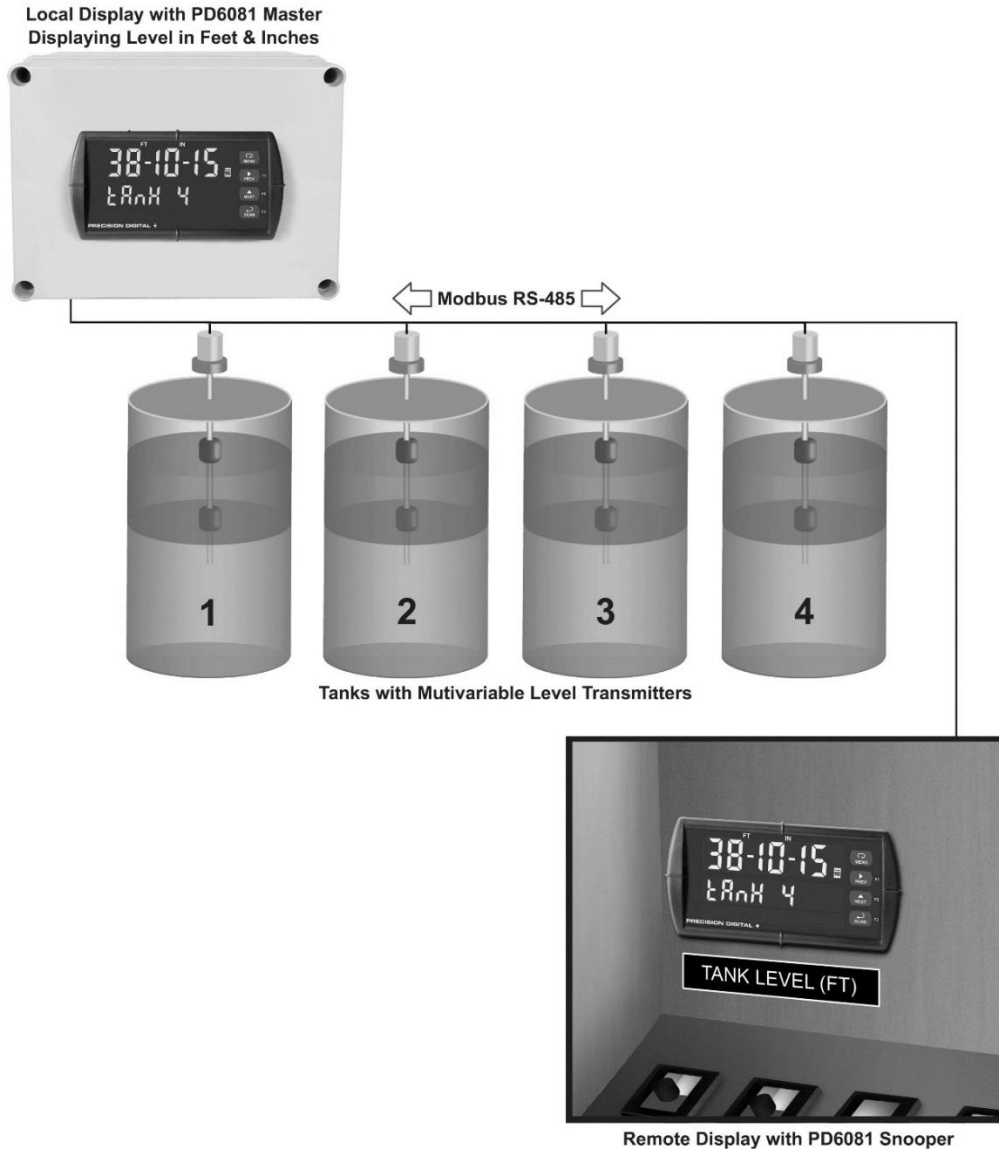

Register Numbers & Process Variables

30001 - Product Level

30003 - Interface Level

30017 - Average Temperature

Note: The example above shows the PD6081. The setup of the scanner is the same as the first example. The PD6081's Feet & Inches display is clearly visible.

Setting the Relay Operation (rELAY)

This menu is used to set up the assignment and operation of the relays.

Relay Setup Menu (rELAY SEtUP)

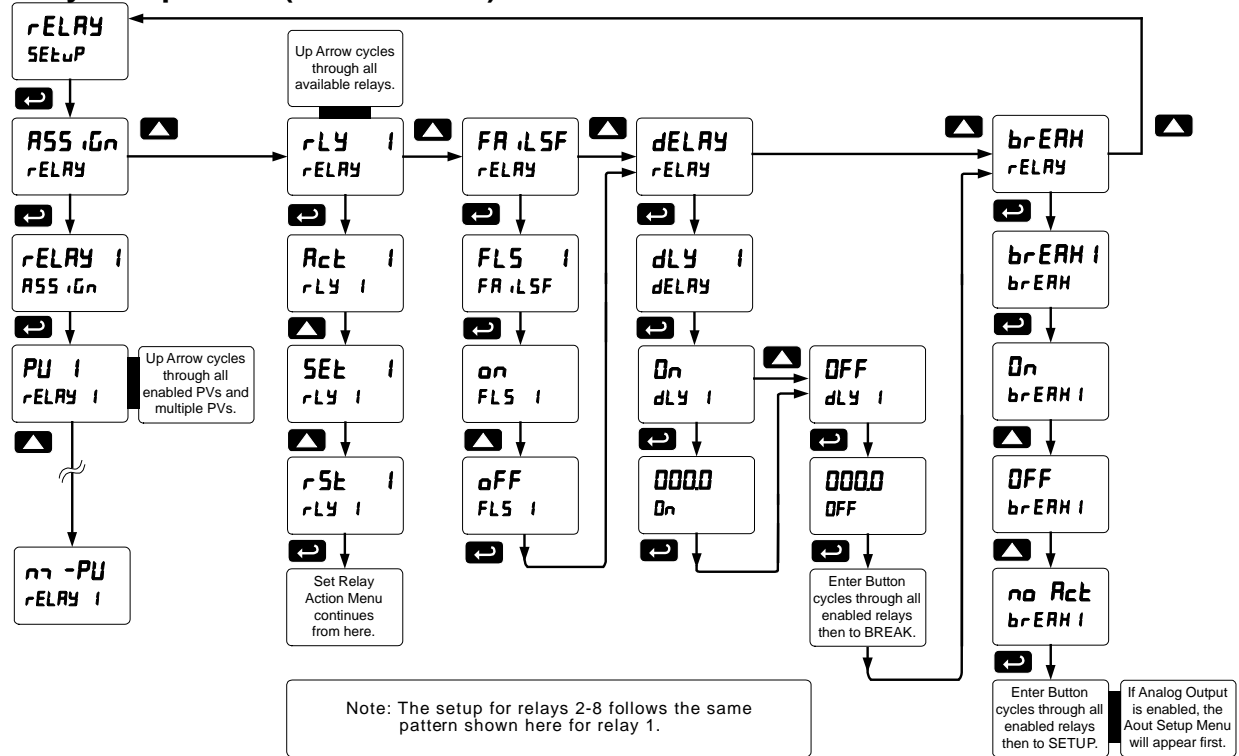

Caution!

During setup, the relays do not follow the input and they will remain in the state found prior to entering the Relay menu.

1. **Assign** Relay assignment
 - a. Assign relay to PV
 - b. Assign relay to Math channel
 - c. Assign relay to multiple PVs (2 to 16 PVs)
2. **Act 1** Relay action
 - a. Automatic reset only (non-latching)
 - b. Automatic + manual reset at any time (non-latching)
 - c. Latching (manual reset only)
 - d. Latching with Clear (manual reset only after alarm condition has cleared)
 - e. Pump alternation control (automatic reset only)
 - f. Sampling (the relay is activated for a user-specified time)
 - g. Off (relay state controlled by Interlock feature)
3. **Set 1** Set point & **Rst 1** Reset point
4. **Failst** Fail-safe operation
 - a. On (enabled)
 - b. Off (disabled)
5. **Delay** Time delay
 - a. On delay (0-999.9 seconds)
 - b. Off delay (0-999.9 seconds)
6. **Break** Relay action for communications break or loss of 4-20 mA input

Setting the Relay Action (act 1)

Operation of the relays is programmed in the *Action* menu. The relays may be set up for any of the following modes of operation:

1. **Auto** Automatic reset (non-latching)
2. **A-nman** Automatic + manual reset at any time (non-latching)
3. **latch** Latching (manual reset only, at any time)
4. **lt-CLr** Latching with Clear (manual reset only after alarm condition has cleared)
5. **Altern** Pump alternation control (automatic reset only)
6. **Sanmpl** Sampling (the relay is activated for a user-specified time)
7. **oFF** Off (relay state controlled by Interlock feature)

The following graphic shows relay 1 action setup; relay 2-4 are set up in a similar fashion.

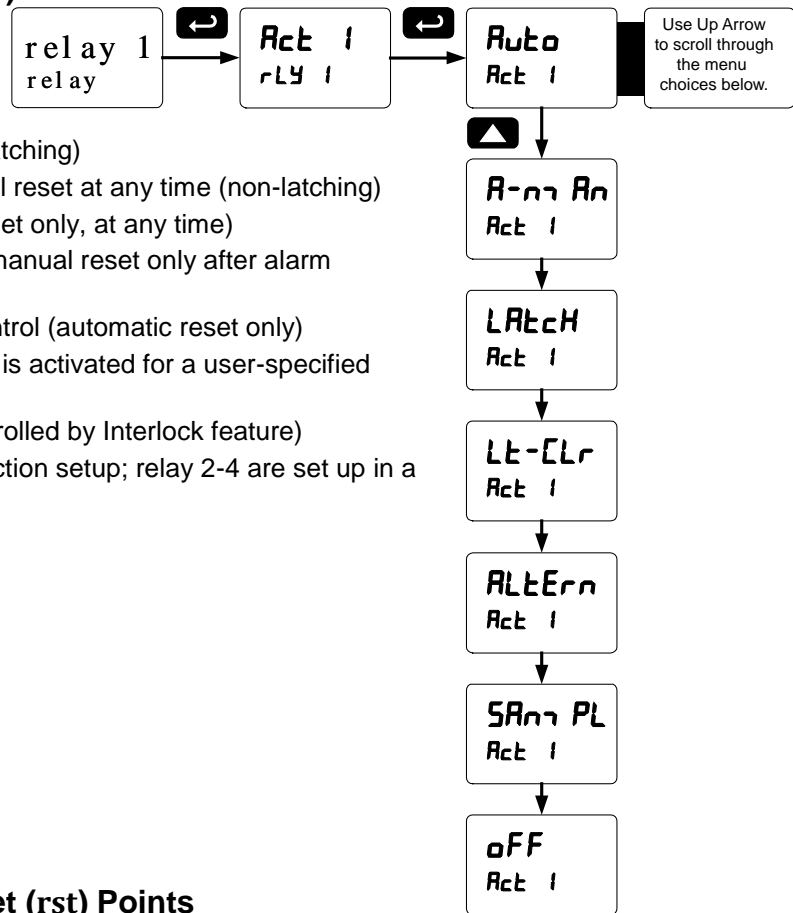

Programming Set (set) & Reset (rst) Points

High alarm indication: program set point above reset point.

Low alarm indication: program set point below reset point.

The deadband is defined as the difference between set and reset points. Minimum deadband is one display count. If the set and reset points are programmed with the same value, the relay will reset one count below the set point.

Note: Changes are not saved until the reset point has been accepted.

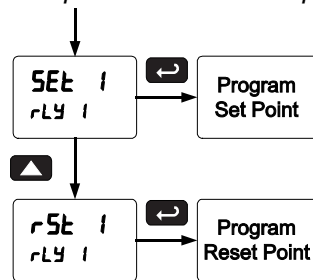

Setting Fail-Safe Operation (failsf)

In fail-safe mode of operation, the relay coil is energized when the process variable is within safe limits and the relay coil is de-energized when the alarm condition exists. The fail-safe operation is set independently for each relay. Select **on** to enable or select **oFF** to disable fail-safe operation.

Programming Time Delay (delay)

The *On* and *Off* time delays may be programmed for each relay between 0 and 999.9 seconds. The relays will transfer only after the condition has been maintained for the corresponding time delay.

The *On* time delay is associated with the set point.

The *Off* time delay is associated with the reset point.

Relay Action for Communications Break (break)

The Scanner will poll the slave device three times before reporting a communications break condition. After the third failure, the Response Timeout timer starts and will determine the actual time to report a PV in break condition.

1. Turn On (Go to alarm condition)
2. Turn Off (Go to non-alarm condition)
3. No Action (The relays will maintain the last condition)

Relay Action for Loss of 4-20 mA Input (Loop Break)

The loop break feature is associated with the 4-20 mA input. Each relay may be programmed to go to one of the above conditions when the scanner detects the loss of the input signal (i.e. < 0.005 mA).

Notes:

1. This is not dependent on the Communications Break or Response Timeout setting.
2. This is not a true loop break condition; if the signal drops below 0.005 mA, it is interpreted as a "loop break" condition.

Relay and Alarm Operation Diagrams

The following graphs illustrate the operation of the relays, status LEDs, and ACK button.

High Alarm Operation (Set > Reset)

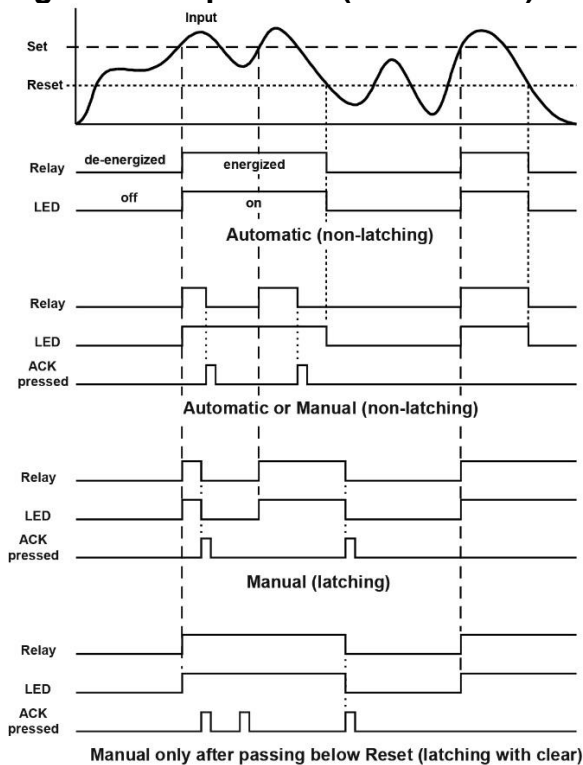

For Manual reset mode, ACK can be pressed anytime to turn "off" relay. To detect a new alarm condition, the signal must go below the set point, and then go above it.

Low Alarm Operation (Set < Reset)

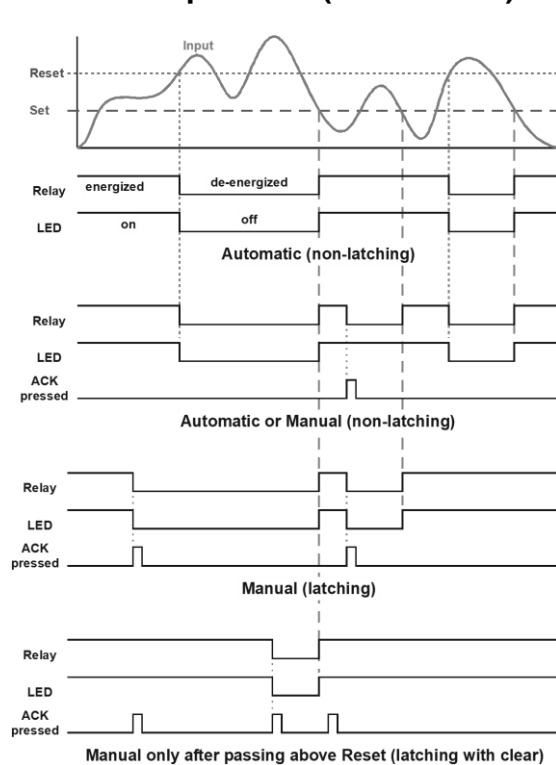

For Manual reset mode, ACK can be pressed anytime to turn "off" relay. For relay to turn back "on", signal must go above set point, and then go below it.

High Alarm with Fail-Safe Operation (Set > Reset)

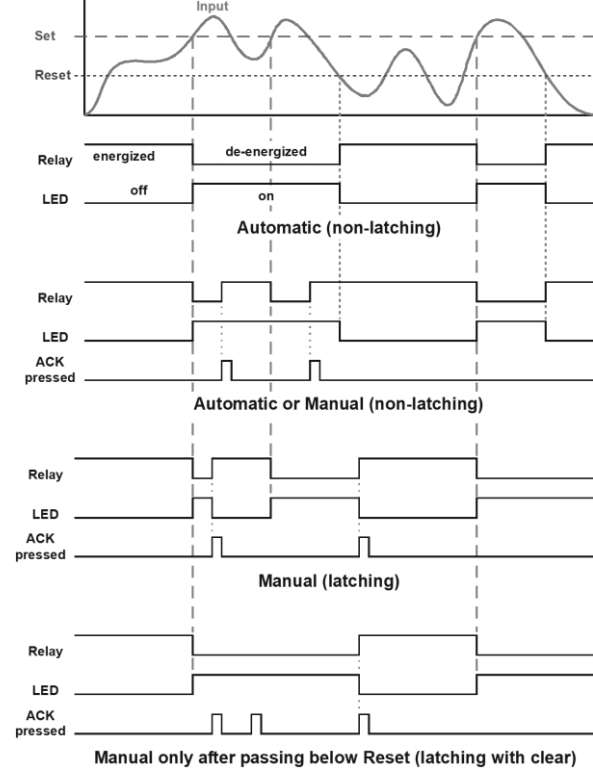

Note: Relay coil is energized in non-alarm condition. In case of power failure, relay will go to alarm state.

Low Alarm with Fail-Safe Operation (Set < Reset)

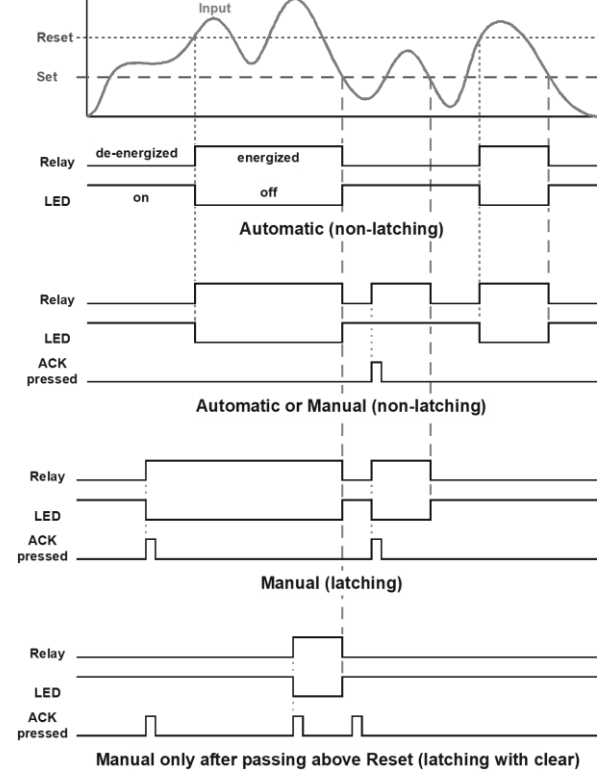

Note: Relay coil is energized in non-alarm condition. In case of power failure, relay will go to alarm state.

Pump Alternation Control Operation

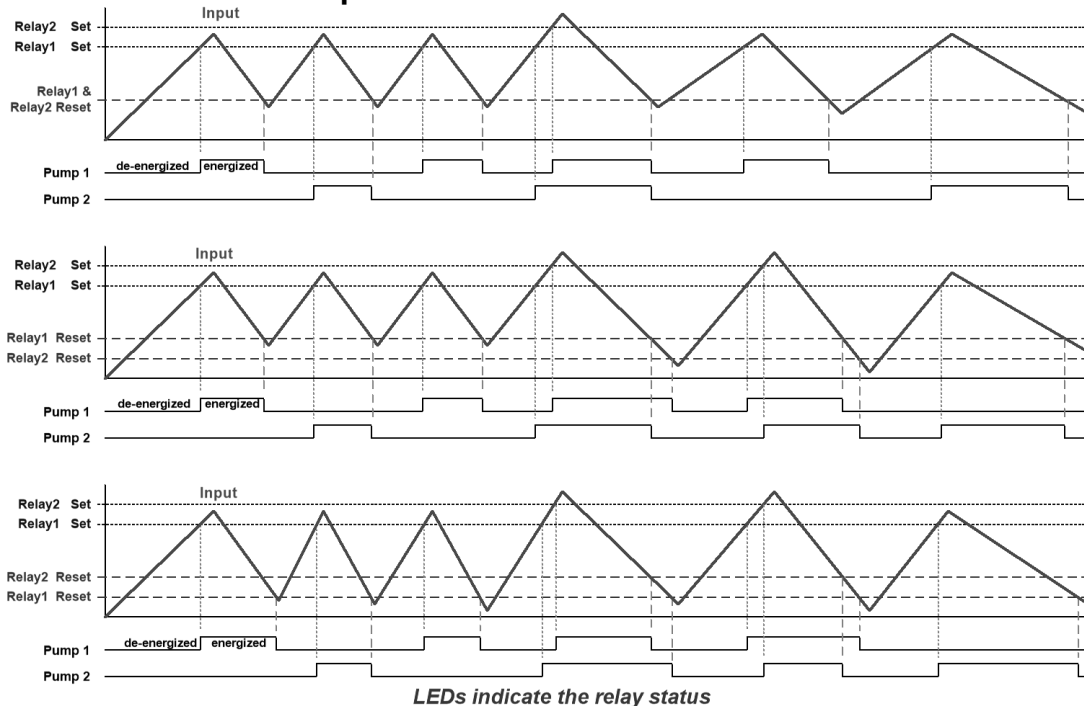

Relay Sampling Operation

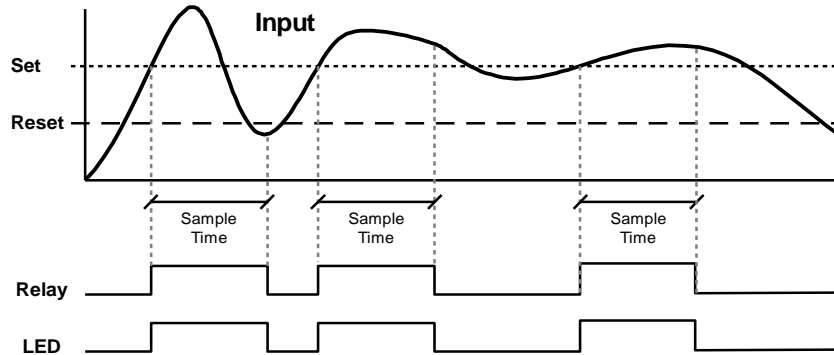

When the signal crosses the set point, the relay trips and the sample time starts. After the sample time has elapsed, the relay resets. The cycle repeats every time the set point is crossed, going up for high alarms and going down for low alarms.

The sample time can be programmed between 0.1 and 5999.9 seconds.

Relay Operation After Communications Break

When a Master scanner fails to receive a reply from the slave it is called a Communications Break. The relays can be programmed to react to this event by going On, Off, or No Action. After communication is restored the relays are turned off or on, based on their operating mode and their set and reset points, without regard to their prior state. This is similar to the auto initialization on power up. Below is a diagram showing three examples.

The same is true for a scanner set up to operate in Snooper mode.

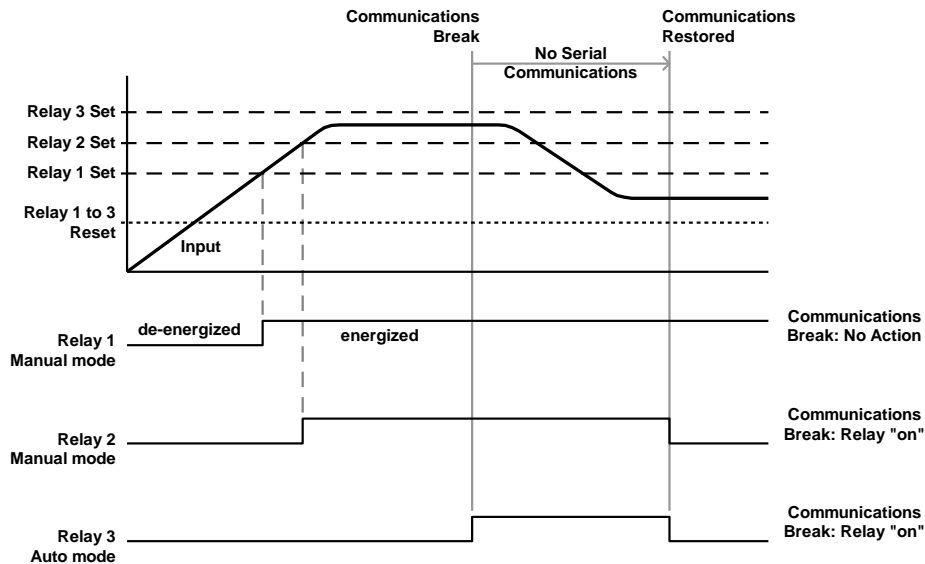

Signal Loss or Loop Break Relay Operation

The following graph shows the loop break relay operation for a high alarm relay.

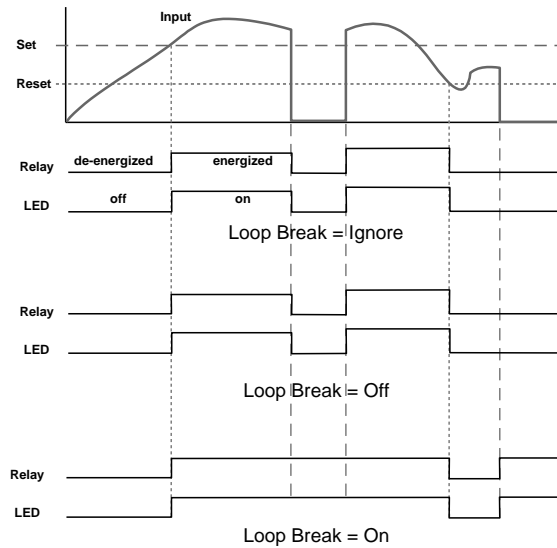

When the scanner detects a break in the 4-20 mA loop, the relay will go to one of the following selected actions:

1. Turn *On* (Go to alarm condition)
2. Turn *Off* (Go to non-alarm condition)
3. No action (**no Act**) (Processed as a low signal condition)

Time Delay Operation

The following graphs show the operation of the time delay function.

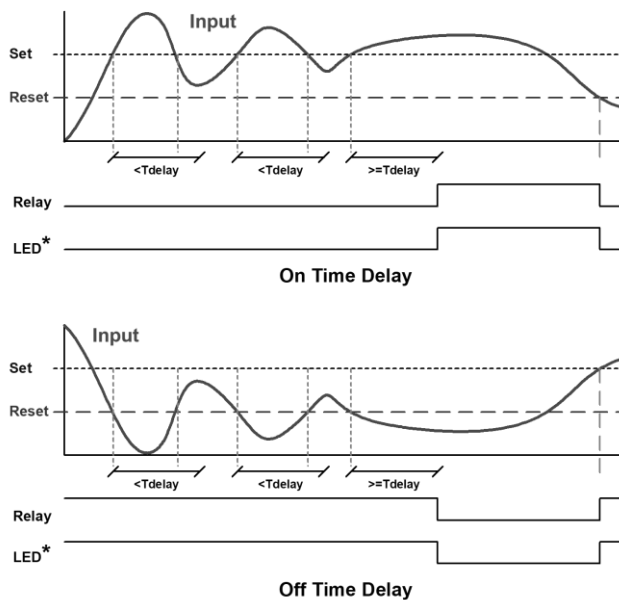

When the signal crosses the set point, the *On* time delay timer starts and the relay trips when the time delay has elapsed. If the signal drops below the set point (high alarm) before the time delay has elapsed, the *On* time delay timer resets and the relay does not change state. The same principle applies to the *Off* time delay.

Note: If "Automatic or Manual (R-n Rn)" reset mode is selected, the LED follows the reset point and not the relay state when the relay is acknowledged.

Relay Operation Details

Overview

The relay capabilities of the scanner expand its usefulness beyond simple indication to provide users with alarm and control functions. These capabilities include front panel alarm status LEDs, as well as either 2 or 4 optional internal relays. Typical applications include high or low temperature, level, pressure or flow alarms, control applications such as simple on/off pump control, and pump alternation control for up to 4 pumps. There are four basic ways the relays can be used:

1. High or Low Alarms with Latching or Non-Latching Relays
2. Simple On/Off Control with 100% Adjustable Deadband
3. Sampling (Based on Time)
4. Pump Alternation Control for up to 4 Pumps

Relays Auto Initialization

When power is applied to the scanner, the front panel LEDs and alarm relays will reflect the state of the input to the scanner after the first response from the slave device. The following table indicates how the alarm LEDs and relays will react on power-up based on the set and reset points:

Alarm #	HI or LO Alarm	Set Point	Reset Point	Power-Up Reading	Relay & LED
1	HI	1000	500	499	Off
2	LO	700	900	499	On
3	LO	250	400	499	Off
4	HI	450	200	499	On

Fail-Safe Operation (FR LSF)

The following table indicates how the relays behave based on the fail-safe selection for each relay:

Fail-Safe Selection	Non-Alarm State		Alarm State		Power Failure
	NO	NC	NO	NC	
Off	Open	Closed	Closed	Open	Relays go to non-alarm state
On	Closed	Open	Open	Closed	Relays go to alarm state

Note: NO = Normally Open, NC = Normally Closed. This refers to the condition of the relay contacts when the power to the scanner is off.

Front Panel LEDs

The LEDs on the front panel provide status indication for the following:

LED	Status
1	Alarm 1
2	Alarm 2
3	Alarm 3
4	Alarm 4

LED	Status
5	Alarm 5
6	Alarm 6
7	Alarm 7
8	Alarm 8

The scanner is supplied with four alarm points that include front panel LEDs to indicate alarm conditions. This standard feature is particularly useful for alarm applications that require visual-only indication. The LEDs are controlled by the set and reset points programmed by the user. When the display reaches a set point for a high or low alarm, the corresponding alarm LED will turn on. When the display returns to the reset point the LED will go off. The front panel LEDs respond differently for latching and non-latching relays.

For non-latching relays, the LED is always off during normal condition and always on during alarm condition, regardless of the state of the relay (e.g. Relay acknowledged after alarm condition).

For latching relays, the alarm LEDs reflect the status of the relays, regardless of the alarm condition. The following tables illustrate how the alarm LEDs function in relation to the relays and the acknowledge button (Default: F3 key assigned to ACK):

Latching and Non-Latching Relay Operation

The relays can be set up for latching (manual reset) or non-latching (automatic reset) operation.

The On and Off terminology does not refer to the status of the relay's coil, which depends on the fail-safe mode selected.

Relay terminology for following tables	
Terminology	Relay Condition
On	Alarm (Tripped)
Off	Normal (Reset)
Ack	Acknowledged



Warning!

In latching relay mode, latched relays will reset (unlatch) when power is cycled.

Non-Latching Relay (R_ut_o)

In this application, the scanner is set up for automatic reset (non-latching relay). Acknowledging the alarm while it is still present has no effect on either the LED or the relay. When the alarm finally goes away, the relay automatically resets and the LED also goes off.

Automatic reset only		
Condition	LED	Relay
Normal	Off	Off
Alarm	On	On
Ack (No effect)	On	On
Normal	Off	Off

Non-Latching Relay (R_n-n_r R_n)

In this application, the scanner is set up for automatic and manual reset at any time (non-latching relay). The LED and the relay automatically reset when the scanner returns to the normal condition.

The next time an alarm occurs, the operator acknowledges the alarm manually while the alarm condition still exists. This causes the relay to reset, but the LED stays on until the scanner returns to the normal condition.

Automatic + manual reset at any time		
Condition	LED	Relay
Normal	Off	Off
Alarm	On	On
Normal	Off	Off
Next Alarm	On	On
Ack	On	Off
Normal	Off	Off

Latching Relay (L_Rt_oH)

In this application, the scanner is set up for manual reset at any time. Acknowledging the alarm even if the alarm condition is still present resets the relay and turns off the LED.

Manual reset any time		
Condition	LED	Relay
Normal	Off	Off
Alarm	On	On
Ack	Off	Off

Latching Relay (L_t-[L_r)

In this application, the scanner is set up for manual reset only after the signal passes the reset point (alarm condition has cleared). Acknowledging the alarm while it is still present has no effect on either the LED or the relay. When the alarm is acknowledged after it returns to the normal state, the LED and the relay go off. Notice that the LED remains on, even after the scanner returns to the normal condition. This is because, for latching relays, the alarm LED reflects the status of the relay, regardless of the alarm condition.

Manual reset only after alarm condition has cleared		
Condition	LED	Relay
Normal	Off	Off
Alarm	On	On
Ack (No effect)	On	On
Normal	On	On
Ack	Off	Off

Acknowledging Relays

There are two ways to acknowledge relays programmed for manual reset:

1. Via the programmable F4 digital input assigned to ACK (Default) and connected to a normally open pushbutton wired across F4 and COM.
2. Remotely via a normally open pushbutton wired across one of the digital inputs and the +5 V terminals on the digital I/O modules, which is triggered with a contact closure to COM, or with an active low signal (see page8).

When the ACK button or the assigned digital input is closed, all relays programmed for manual reset are acknowledged.

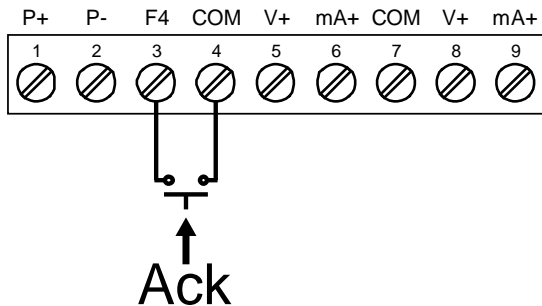

Figure 19. Acknowledge Relays with F4 Function Key

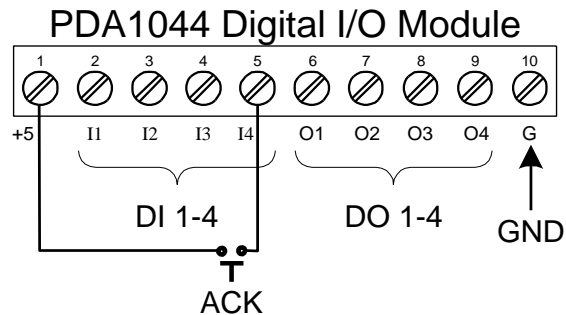

Figure 20. Acknowledge Relays with Digital Input

Pump Alternation Control Applications (ALTErn)

For pump control applications where two or more similar pumps are used to control the level of a tank or a well, it is desirable to have all the pumps operate alternately. This prevents excessive wear and overheating of one pump over the lack of use of the other pumps.

Up to 4 relays can be set up to alternate every time an on/off pump cycle is completed. The set points and reset points can be programmed, so that the first pump on is the first pump off.

Application #1: Pump Alternation Using Relays 1 & 2

1. Relays 1 and 2 are set up for pump alternation.
2. Relays 3 and 4 are set up for low and high alarm indication.

Set and Reset Point Programming with Pump Alternation			
Relay	Set Point	Reset Point	Function
1	30.000	10.000	Controls pump 1 & 2
2	35.000	5.000	Sets dual pump trigger
3	4.000	9.000	Controls low alarm
4	40.000	29.000	Controls high alarm

Pump Alternation Operation

1. Pump #1 turns on when the level reaches 30.000, when level drops below 10.000 pump #1 turns off.
2. The next time the level reaches 30.000, pump #2 turns on, when the level drops below 10.000, pump #2 turns off.
3. If the level doesn't reach 35.000 pump #1 and pump #2 will be operating alternately.
4. If pump #1 cannot keep the level below 35.000 pump #2 will turn on at 35.000, then as the level drops to 10.000 pump #1 turns off, pump #2 is still running and shuts off below 5.000.
5. Notice that with the set and reset points of pump #2 outside the range of pump #1, the first pump on is the first pump to go off. This is true for up to 4 alternating pumps, if set up accordingly.
6. Relay #3 will go into alarm if the level drops below 4.000 and relay #4 will go into alarm if the level exceeds 40.000.

Setting Up the Interlock Relay (Force On) Feature

Relays 1-4 can be set up as interlock relays. To set up the relays for the interlock feature:

1. Access the *Setup – Relay – Action* menu and set the action to off.

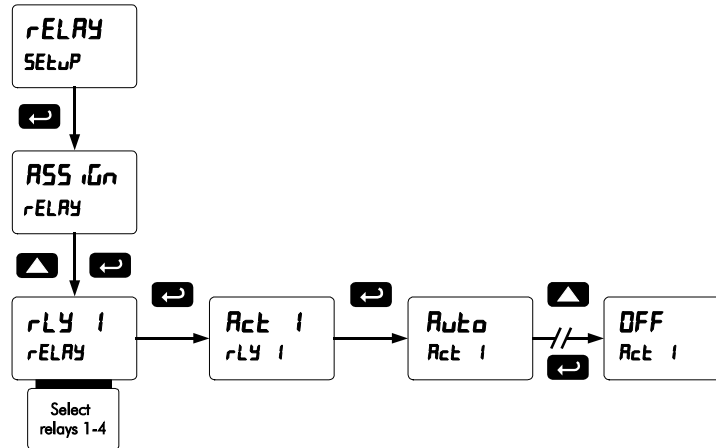

2. In the *Advanced features – User* menu, program any of the digital inputs to *Force On* any of the internal relays (1-4). The *Advanced Features Menu* can be found on page 58.

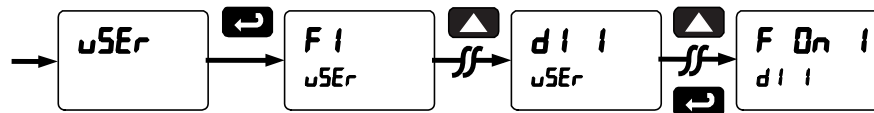

3. Connect a switch or dry contact between the +5V terminal and the corresponding digital input (dl-1 to dl-4) terminal.

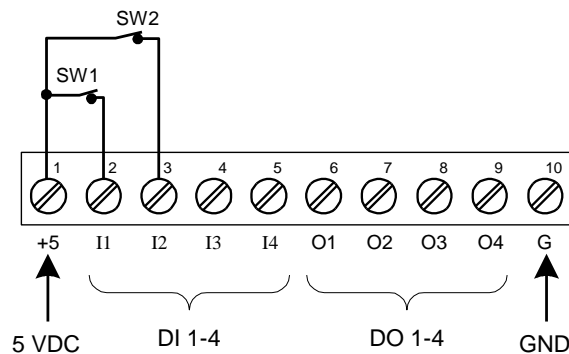

Interlock Relay Operation Example

Relays 1 & 2 are configured to energize (their front panel LEDs are off) when SW1 & SW2 switches (above) are closed. If the contacts to these digital inputs are opened, the corresponding front panel LEDs flash, indicating this condition. The processes being controlled by the interlock relay will stop, and will re-start only after the interlock relay is re-activated by the digital inputs (switches).

Note: If multiple digital inputs are assigned to the same relay, then the corresponding logic is (AND) – i.e. both switches must be closed to trip the relay.

Scaling the 4-20 mA Analog Output (Aout)

The 4-20 mA analog outputs can be scaled to provide a 4-20 mA signal for any display range selected. The Analog Outputs can be mapped to PVs or Math Channels. To select the channel and source assignments the analog outputs are assigned to, see *Analog Output Source Programming* on page 71.

No equipment is needed to scale the analog outputs; simply program the display values to the corresponding mA output signal.

The *Analog Output* menu is used to program the 4-20 mA outputs based on display values.

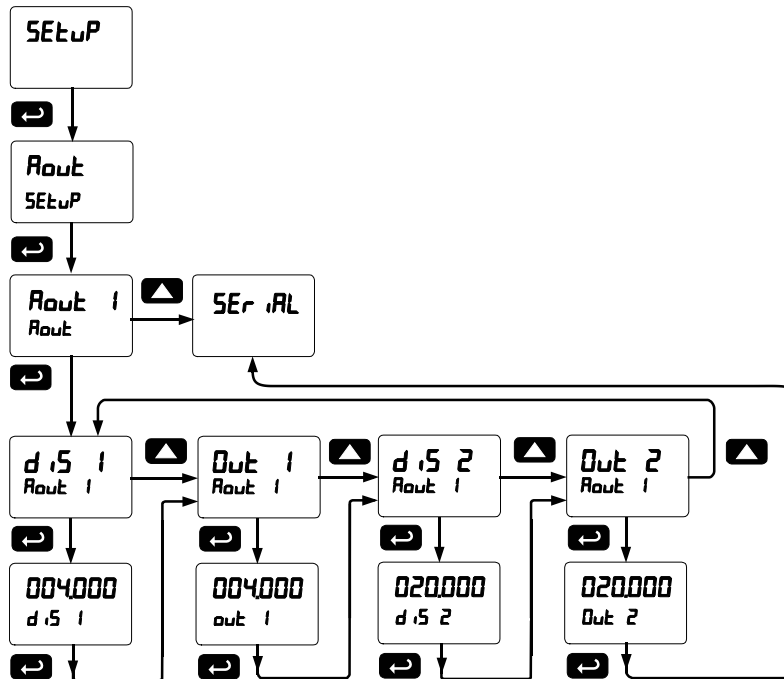

There are three analog outputs available. These only display when they are enabled. See graphic below.

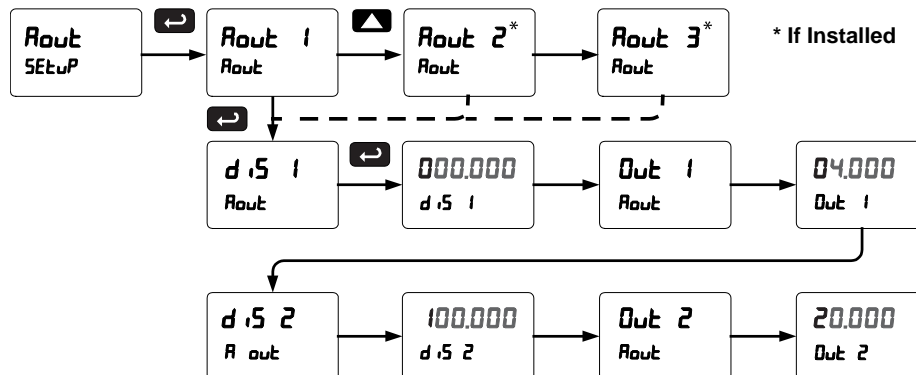

Notes: Changes to the settings are saved to memory only after pressing ENTER. Changes made to settings prior to pressing ENTER are not saved. Once ENTER is pressed, the display moves to the next menu.

Setting Up the Password (PASS)

The *Password* menu is used for programming three levels of security to prevent unauthorized changes to the programmed parameter settings.

Pass 1: Allows use of function keys and digital inputs
 Pass 2: Allows use of function keys, digital inputs and editing set/reset points
 Pass 3: Restricts all programming, function keys, and digital inputs.

Protecting or Locking the Scanner

Enter the *Password* menu and program a six-digit password.

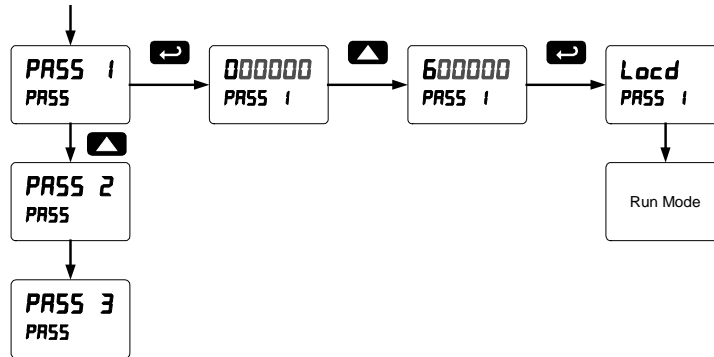

Making Changes to a Password Protected Scanner

If the scanner is password protected, the scanner will display the message **Locd** (*Locked*) when the Menu button is pressed. Press the Enter button while the message is being displayed and enter the correct password to gain access to the menu. After exiting the programming mode, the scanner returns to its password protected condition.

Disabling Password Protection

To disable the password protection, access the *Password* menu and enter the correct password twice, as shown below. The scanner is now unprotected until a new password is entered.

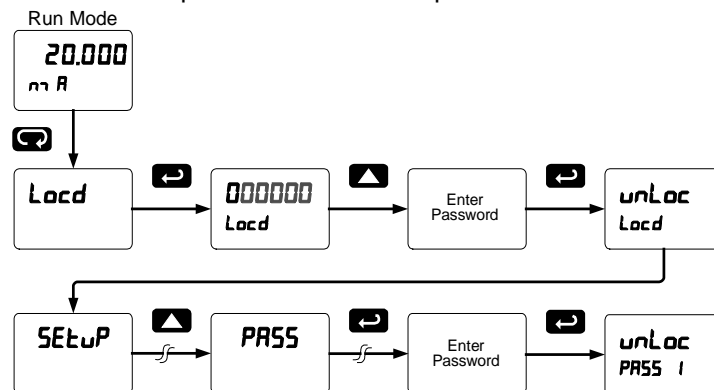

If the correct six-digit password is entered, the scanner displays the message **unLoc** (*Unlocked*) and the protection is disabled until a new password is programmed.

If the password entered is incorrect, the scanner displays the message **Locd** (*Locked*) for about two seconds, and then it returns to Run Mode. To try again, press Enter while the *Locked* message is displayed.

Did you forget the password?

The password may be disabled by entering a master password once. If you are authorized to make changes, enter the master password 508655 to unlock the scanner.

Advanced Features Menu

To simplify the setup process, functions not needed for most applications are located in the *Advanced Features* menu:

1. *Scan Mode: Auto or manual; Go on alarm or stop on alarm*
2. *Control relays and analog output*
3. *Noise Filter*
4. *Noise Filter Bypass*
5. *Rounding Feature*
6. *Select Math, Linearization function, Cutoff*
7. *User Programming for function keys and digital I/O*
8. *Analog Channels Input Calibration*
9. *System Information*

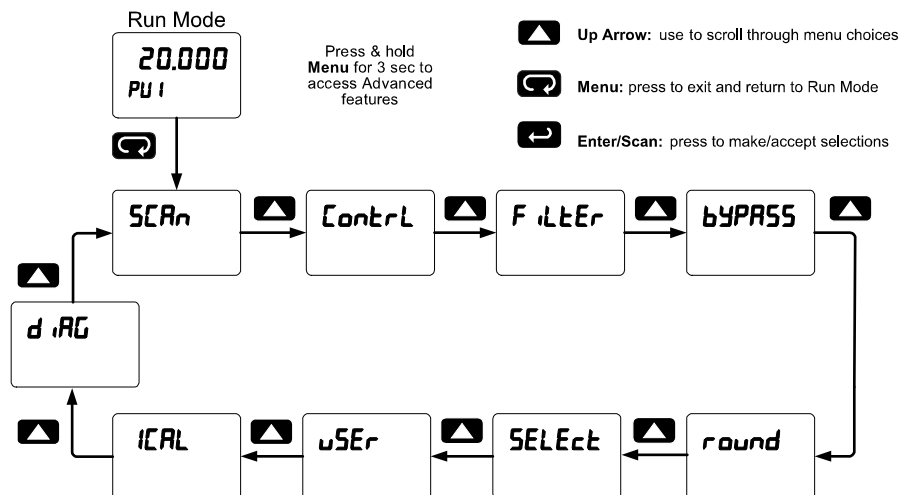

Advanced Menu Navigation Tips

- Press and hold the **Menu** button for three seconds to access the Advanced Features Menu.
- Press the **Up** arrow button to scroll through the Advanced Features Menu.
- Press **Menu** at any time, to exit and return to Run mode.
- Changes made to settings prior to pressing **Enter/Scan** are not saved.
- Changes to the settings are saved to memory only after pressing **Enter/Scan**.
- The display automatically moves to the next menu every time a setting is accepted by pressing **Enter/Scan**.

Advanced Features Menu & Display Messages

Display	Parameter	Action/Setting
SCAN	Scan	Enter Scan menu
Mode	Scan Mode	Select Auto or Manual Scan Mode
Auto	Automatic	Select Automatic Scan Mode
Time	Scan Time	Select Scanning Time
Man	Manual	Select Manual Scan Mode
ALARM	Alarm	Select Go or Stop Alarm
Go	Go	Select Alarm Go
Stop	Stop	Select Alarm Stop
CONTROL	Control	Enter Control menu for relays and analog output 1
Auto	Automatic	Select Automatic Control of Outputs and Relays
Man	Manual	Select Manual Control of Outputs and Relays
Out 1	Analog Output 1	Select Analog Output 1 for manual control
Relay 1	Relay 1	Select Relay 1-4 for manual control
On	On	Select On for Relay 1-8
Off	Off	Select Off for Relay 1-8
Filter	Filter	Enter Filter menu
PV 1	PV 1 Filter	Program Filter Value for PV 1
PV 2	PV 2 Filter	Program Filter Value for PV 2
bypass	Filter Bypass	Enter Filter Bypass menu
PV 1	PV 1 Filter Bypass	Program Filter Bypass Value for PV 1
PV 2	PV 2 Filter Bypass	Program Filter Bypass Value for PV 2
round	Rounding Feature	Enter Rounding Feature menu
1*	1 Rounding Value	Program Rounding Value for PV *(User-selectable & rounds to the nearest 1, 2, 5, 10, 20, 50, 100)
SELECT	Select	Enter Select menu
Function	Function	Enter data Linearization Function menu
PV 1*	PV 1 Function	*Enter Linearization Function menu for all enabled PVs
Ch C1*	Ch C1 Function	*Enter Linearization Function menu for all enabled math channels
Linear	Linear	Enter Linear menu
Number of Points	Number of Points	Enter Number of Linearization Points
SCALE	Scale	Scale Number of Linearization Points
inP 1	Input 1	Calibrate input 1 signal or program input 1 value
Display 1	Display 1	Program display 1 value
inP 2	Input 2	Calibrate input 2 signal or program input 2 value (up to 3; points for PV1 & PV2)

Display	Parameter	Action/Setting
Display 2	Display 2	Program display 2 value (up to 32 points for PV1 & PV2)
Square Root	Square Root	Enter Square Root menu
Programmable Exponent	Programmable Exponent	Enter Programmable Exponent menu
Programmable Exponent Value	Programmable Exponent Value	Enter the Programmable Exponent Value
Round Horizontal Tank	Round Horizontal Tank	Enter Round Horizontal Tank menu
Inch	Inch	Enter to calculate tank values in Inches
Centimeters	Centimeters	Enter to calculate tank values in Centimeters
Diameter	Diameter	Enter tank diameter
Length	Length	Enter tank length
Math	Math	Enter Math menu
Channel C1*	Channel C1	*Enter Math Channel C1-C4 menu
Operation	Operation	Enter Math Operation menu
Constant	Constant	Enter Math Constant menu
Adder	Adder	Enter Adder Value
Factor	Factor	Enter Factor Value
Sum	Sum	Math Function Sum
Difference	Difference	Math Function Difference
Absolute Difference	Absolute Difference	Math Function Absolute Difference
Average	Average	Math Function Average
Multiply	Multiply	Math Function Multiply
Divide	Divide	Math Function Divide
Max	Max	Math Function Maximum of all selected PVs
Min	Min	Math Function Minimum of all selected PVs
Draw	Draw	Math Function Draw
Weighted Average	Weighted Average	Math Function Weighted Average
Ratio	Ratio	Math Function Ratio
Concentration	Concentration	Math Function Concentration
Math2	Math2	Resultant Math Channel Math operation applied to other math channels (e.g. C3 = C1/C2)
Sum	Sum	Math2 Function Sum
Difference	Difference	Math2 Function Difference
Absolute Difference	Absolute Difference	Math2 Function Absolute Difference
Average	Average	Math2 Function Average
Multiply	Multiply	Math2 Function Multiply
Divide	Divide	Math2 Function Divide
Cutoff	Cutoff	Enter Low Flow Cutoff menu
PV 1	PV 1 Cutoff	Program Cutoff Value for PV 1

Display	Parameter	Action/Setting
PV 2	PV 2 Cutoff	Program Cutoff Value for PV 2
Pr	Analog Output Program	Enter Analog Output Programmable parameters menu
Pr 1*	Analog Output 1-3	*Analog Output 1-3 (If Installed)
Source	Analog Output Data Source	Enter Analog Output Data Source menu
PV 1*	Source PV	*Select PV for Analog Output Data Source
Ch C 1*	Source Math Channel	*Select C1-4 for Analog Output Data Source
SE 1*	Set Point 1-8	*Select Set Points 1-8
br	Communications Break	Enter the Analog Output value when Communications Break is detected
br	Ignore Break	Ignore Break
For	Force Break	Force Break
Cal	Calibration	Enter the Analog Output Calibration menu
Max	Maximum	Select Maximum value for all Analog Outputs
Min	Minimum	Select Minimum value for all Analog Outputs
Or	Overrange	Enter the Analog Output value for an Overrange condition
Un	Underrange	Enter the Analog Output value for an Underrange condition
User	User	Enter the User menu for assigning function keys and digital I/O
F 1*	F1-4	*F1-F4 Function Keys
Pr	Previous	Previous PV
Next	Next	Next PV
Scan	Scan	Scan or pause scan
Rel	Acknowledge	Acknowledge relays
Reset	Reset	Enter Reset menu
Reset Max	Reset Max	Reset Maximum
Reset Min	Reset Min	Reset Minimum
Reset Max-Min	Reset Max-Min	Reset Maximum & Minimum
Relay	Relay	Relay menu
SE 1*	Set Points 1-8	Set Points 1-8
Relay Disable	Relay Disable	Relay Disable (all relays)
Relay Enable	Relay Enable	Relay Enable (all relays)
Output Hold	Output Hold	Output Hold (all relays)
Display Hold	Display Hold	Display Hold (while held low)
Disable	Disable	Disable

Display	Parameter	Action/Setting
Control	Control	Control menu
DI 1*	DI 1-8	*Digital Inputs 1-8
Menu	Menu	Menu
Right	Right	Right
Up	Up	Up
Enter	Enter	Enter
Force On Relay 1	Force On Relay 1	*Force On Relay 1-4
DO 1*	DO 1-8	*Digital Outputs 1-8
Alarm 1-8	Alarm 1-8	*Alarm 1-8
Acknowledge	Acknowledge	Acknowledge
Reset	Reset	Enter Reset menu
Reset Max	Reset Max	Reset Maximum
Reset Min	Reset Min	Reset Minimum
Reset Max-Min	Reset Max-Min	Reset Maximum & Minimum
Disable	Disable	Disable
Input Calibration	Input Calibration	Enter analog channels Input Calibration menu
Channel A	Channel A	Enter Input Channel A
Channel B	Channel B	Enter Input Channel B
Milliamps	Milliamps	Enter Milliamps
Milliamp Calibration	Milliamp Calibration	Enter Milliamp Calibration
Milliamp Low Signal	Milliamp Low Signal	Enter Milliamp Low Signal
Milliamp High Signal	Milliamp High Signal	Enter Milliamp High Signal
Volts	Volts	Enter Volts
Voltage Calibration	Voltage Calibration	Enter Voltage Calibration
Voltage Low Signal	Voltage Low Signal	Enter Voltage Low Signal
Voltage High Signal	Voltage High Signal	Enter Voltage High Signal
Error	Error	Error Message for Unsuccessful Calibration
Diagnostic	Diagnostic	Enter Diagnostics menu
Reset	Reset	Reset to Factory Defaults
LED Test	LED Test	LEDs cycle through all digits, decimal points, and indicators
Info	Info	Displays Scanner information
Software	Software	Displays Software information
Software Version	Software Version	Displays Software Version information
Erase	Erase	Erase ScanView software stored in meter's memory

Scan Function (SCAN)

The *Scan* menu is used to program the PV scan mode and the scanner's behavior on alarm condition. The operator is able to scan automatically based on a time parameter, or scan manually with front panel keys or digital inputs. The operator is also able to set the scanner to stop on alarm or continue scanning on alarm. To resume scanning the operator must press the Next or Previous button. Please follow the menu below for details. In the Stop on Alarm mode, the scanner will go to the alarmed PV and remain there until the operator manually advances to the next PV or returns to the previous PV. If a new alarm is detected the process is repeated. The scanner ignores old alarms.

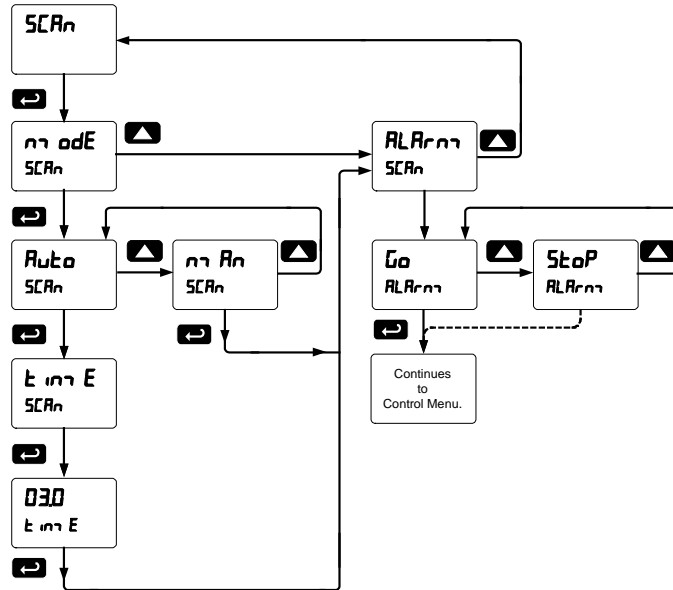

Control Menu (ContrL)

The *Control* menu is used to control the 4-20 mA analog output and the relays manually, ignoring the input. Each relay and analog output can be programmed independently for manual control. Selecting automatic control sets all relays and analog output for automatic operation.

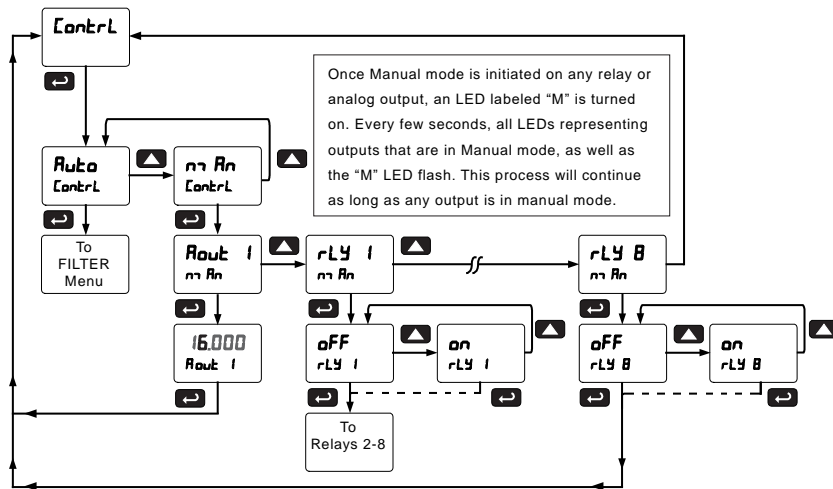

Noise Filter (filter)

Most applications do not require changing this parameter. It is intended to help attain a steady display with unsteady (noisy) input data. The field selectable noise filter averages any minor or quick changes in the input data and displays the reading with greater stability. Increasing the filter value will help stabilize the display. However, this will reduce the display response to changes on the input data. The filter level may be set anywhere from 2 to 199. Setting the filter value to zero disables the filter function, and the bypass setting becomes irrelevant. This parameter is associated with the analog input channels.

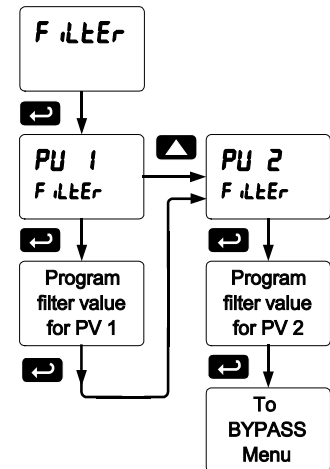

Noise Filter Bypass (bYPASS)

The scanner can be programmed to filter small input changes, but allow larger input changes to be displayed immediately, by setting the bypass value accordingly. If the input signal goes beyond the bypass value, it will be displayed immediately with no averaging done on it. The noise filter bypass value may be set anywhere from 0.2 to 99.9. Increasing the bypass value may slow down the display response to changes on the input signal. This parameter is associated with the analog input channels.

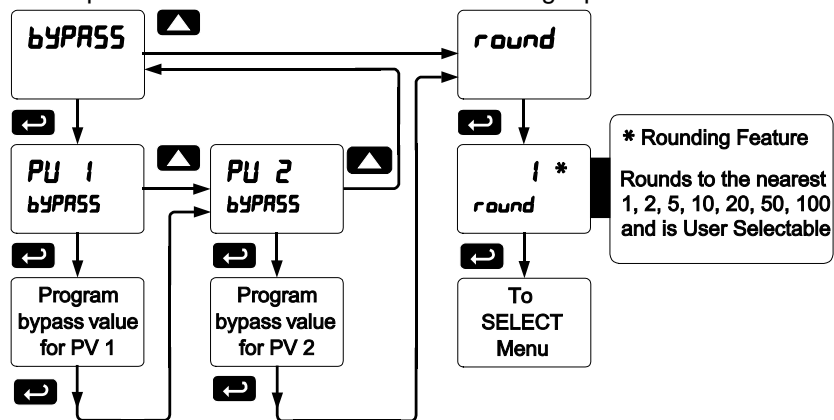

Rounding Feature (round)

The rounding feature is used to give the user a steadier display with fluctuating signals. Rounding is used in addition to the filter function. Rounding causes the display to round to the nearest value according to the rounding criteria selected by the user. This setting affects the last three digits, regardless of decimal point position.

Select Menu (SELEct)

The *Select* menu is used to select the input data linearization function (linear, square root, programmable exponent, or round horizontal tank), math functions, constants, low-flow cutoff, and analog output programming. Multi-point linearization is part of the linear function selection.

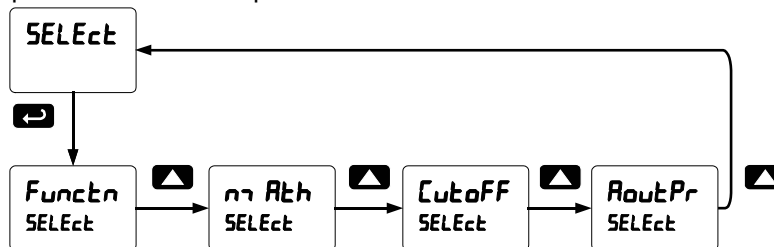

Input Data Conditioning Function Menu (*Func_{tn}*)

The *Function* menu is used to select the input-to-output transfer function applied to the input data: linear, square root, programmable exponent, or round horizontal tank volume calculation. Multi-point linearization (for PV1 and PV2) is part of the linear function selection. Scanners are set up at the factory for linear function with 2-point linearization. The linear function provides a display that is linear with respect to the input data (e.g. 0.000 = 0.000, 10.000 = 10.000, and then 5.000 = 5.000).

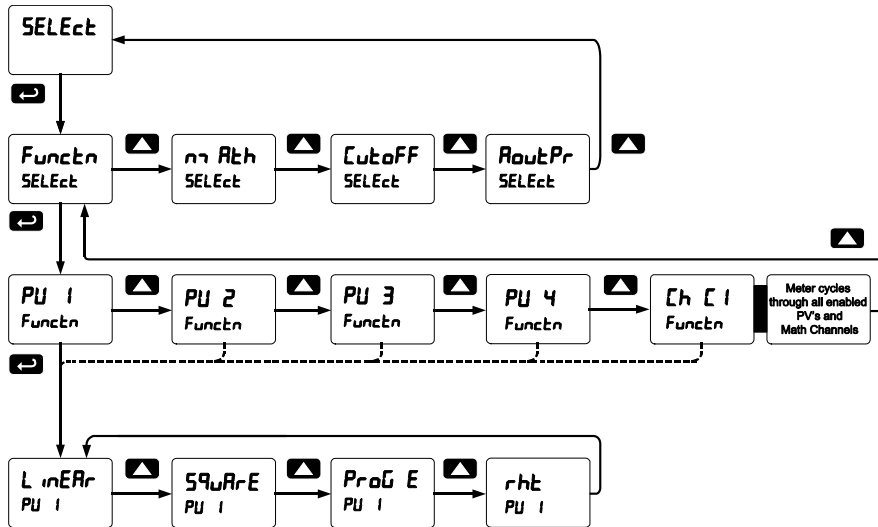

Linear Function Menu (*L inERr*)

Scanners are set up at the factory for linear function with 2-point linearization. Up to 32 linearization points can be selected for PV1 and PV2 under the *Linear* function in the *Advanced Features* menu. The multi-point linearization can be used to linearize the display for non-linear signals such as those from level transmitters used to measure volume in odd-shaped tanks or to convert level to flow using weirs and flumes with complex exponents.

Note: Multi-point Linearization applies to PV1 and PV2 only. All other PVs use two linearization points.

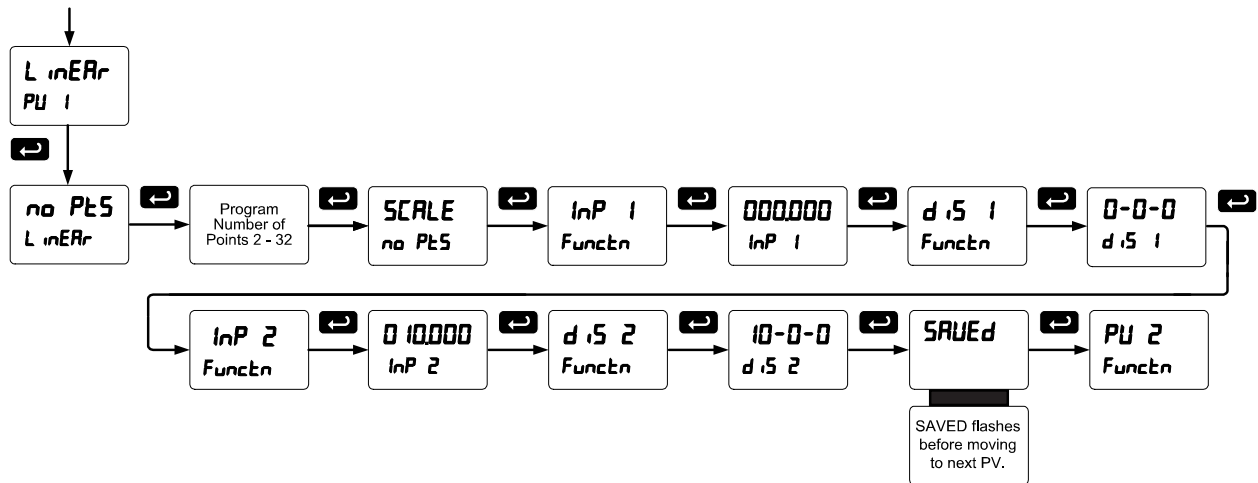

Square Root Function Menu (S_quAr-E)

The square root function is used to calculate flow measured with a differential pressure transmitter. The flow rate is proportional to the square root of the differential pressure. Scale the scanner so that the low input signal (e.g. 4 mA) is equal to zero flow and the high input signal (e.g. 20 mA) is equal to the maximum flow.

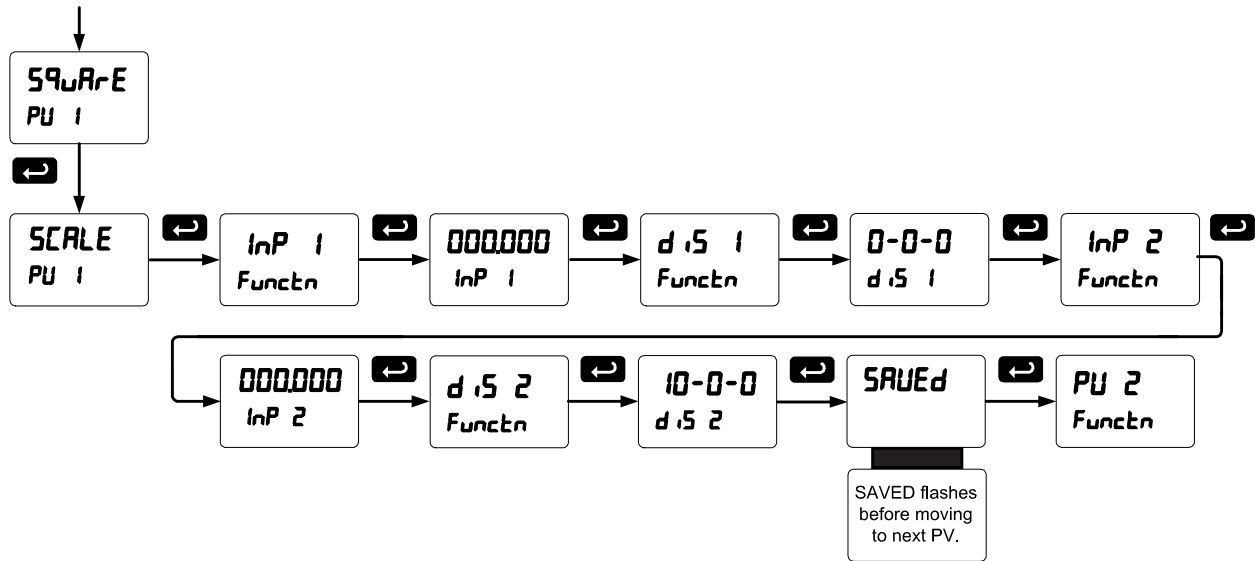

Programmable Exponent Function Menu (Pr_og E)

The programmable exponent function is used to calculate open-channel flow measured with a level transmitter in weirs and flumes. The flow rate is proportional to the head height. Scale the scanner so that the low input signal (e.g. 4 mA) is equal to zero flow and the high input signal (e.g. 20 mA) is equal to the maximum flow. This method works well for all weirs and flumes that have a simple exponent in the flow calculation formula. For weirs and flumes with complex exponents it is necessary to use a strapping table and the 32-point linearization of the scanner.

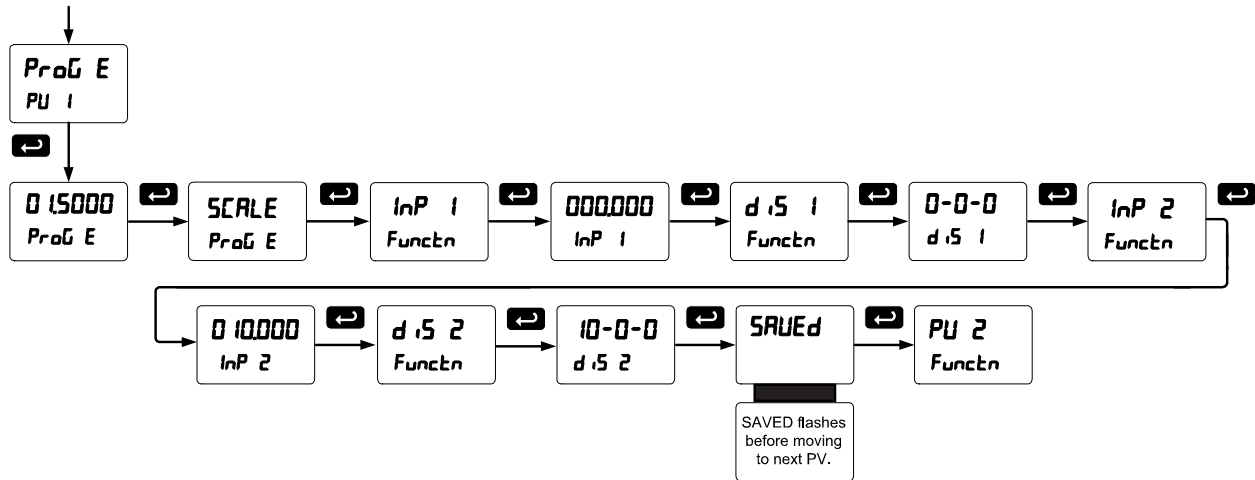

Round Horizontal Tank Function Menu (rht)

This function is used to calculate volume in a round horizontal tank with flat ends. The volume is calculated based on the diameter and length of the tank. The tank's dimensions can be entered in inches or centimeters; the scanner automatically calculates the volume in gallons or liters. After entering the dimensions, complete the scaling process with the display values calculated by the scanner. The scanner can be re-scaled to display the volume in any engineering unit without the need to re-enter the dimensions again.

Changing the Volume from Gallons to Liters

In the graphic, entering the 48" for the diameter and 120" for the length of the round horizontal tank, the scanner automatically calculates that the volume of the tank is 940.02 gallons.

1. Convert gallons to liters
 1 US gallon = 3.7854 L
 940.02 gal = 3558.4 L
2. Go to the *Setup - PV - Decimal Point* menu and change the decimal point to 1 decimal.
3. Go to the *Setup - PV - Scale* menu and press Enter until **d 5 2** is shown on display line 1.
4. Press Enter and change the display 2 value to 3558.4.
5. The scanner is now displaying the volume in liters.

Note: The display can be scaled to display the volume in any engineering units.

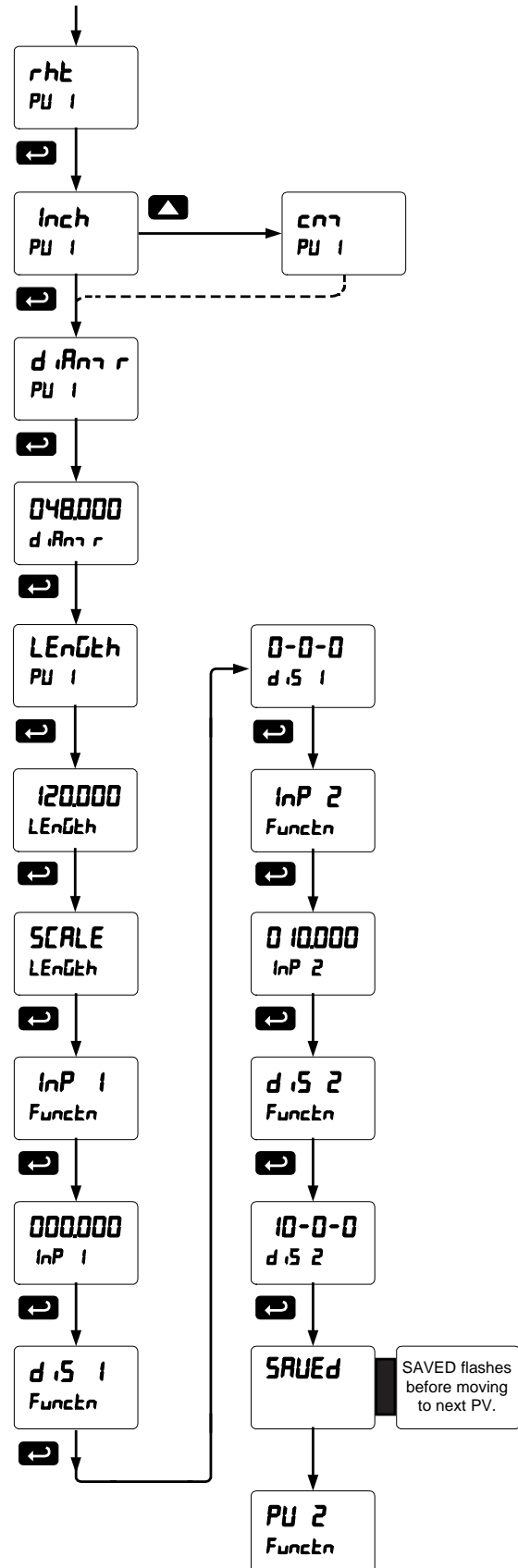

Math Functions (ጠገ ለፎክ)

The *Math* menu is used to select the math function that will determine the channels' C1-C4 value. These math functions are applied to PVs and other math channels. The results are displayed by selecting Display Channel C (ፈ ፎክ ፍ) in the *Display* menu. Most math functions may be applied to all PVs: For example, it is possible to add up to 16 PVs and calculate the total volume of all the tanks in a field. The Math2 function allows for further calculations on the results of other math channels (e.g. C4 = C2/C1).

The following math functions are available:

Name	Math Operation (Examples) (P = Adder, F = Factor)	Setting
Addition	$(PV1+PV2+P)*F$	Sunm
Difference	$(PV1-PV2+P)*F$	diF
Absolute difference	$((Abs(PV1- PV2)+P)*F$	diFAbs
Average	$((PV1+PV2)/2)+P)*F$	AvG
Multiplication	$((PV1*PV2)+P)*F$	Nmulti
Division	$((PV1/PV2)+P)*F$	divide
Max PV	Max value of all selected PVs	Hi-pv
Min PV	Min value of all selected PVs	Lo-pv
Draw	$((PV1/PV2)-1)*F$	drAuw
Weighted average	$((PV2-PV1)*F)+PV1$	uwavg
Ratio	$(PV1/PV2)*F$	Ratio
Concentration	$(PV1/(PV1+PV2))*F$	Concen
Math 2	Math on other math channels	Nmath2
Addition	$C3 = (C1+C2+P)*F$	Sunm
Difference	$C4 = (C1-C2+P)*F$	diF
Absolute difference	$C3 = ((Abs(C1- C2)+P)*F$	diFAbs
Average	$C4 = (((C1+C2)/2)+P)*F$	AvG
Multiplication	$C3 = ((C1*C2)+P)*F$	Nmulti
Division	$C4 = ((C1/C2)+P)*F$	divide

Math Constants (ፎጠፍኑ)

The *Math Constants* menu is used to set the constants used in the math channel. The math functions include the selected PVs, as well as the constants P (Adder) and the Factor F (Multiplier) as indicated in the above examples.

The *Adder* constant (P) may be set from -99.999 to 999.999.

The *Factor* constant (F) may be set from 0.001 to 999.999.

The above chart details the math functions that may be selected in the *Math Function* menu.

Math Function Menu (הר אלה)

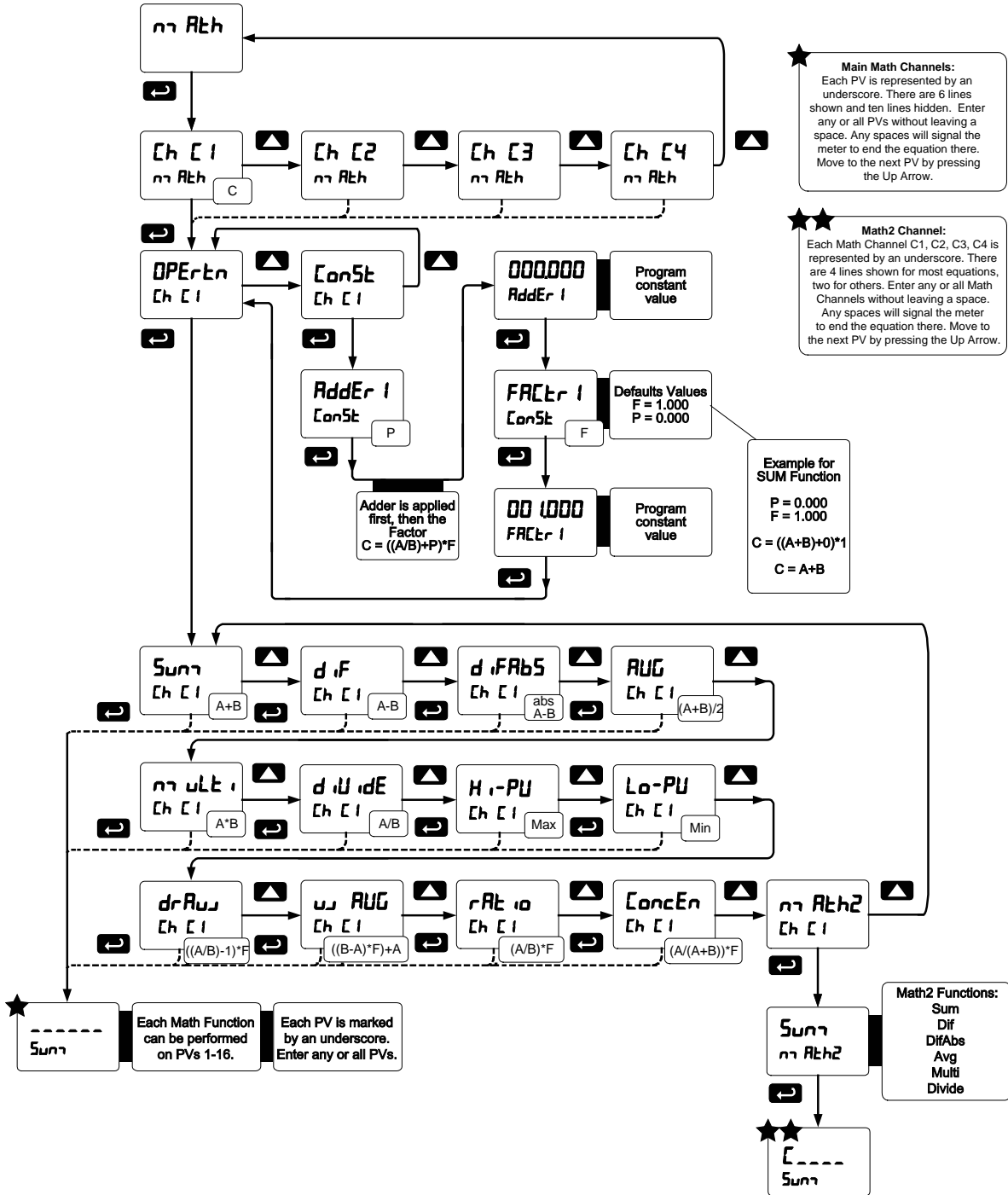

Notes:

1. In the above menu, "A" & "B" in equations can represent any PVs (PV1-PV16). See table above.
2. Each digit represents one PV in hexadecimal format, except PV16 (G).
3. PV1 – PV9 = 1 - 9, PV10 – PV16 = A – G
4. No PV selected = "underscore symbol"
5. Digit range: 1-G, then "_"
6. If there is an empty digit, the scanner will end the equation at that point.
7. For Math2 Channel, "C" is fixed, indicating which Math Channels are being processed.
8. Please refer to the following graphics for details on various Math Functions:

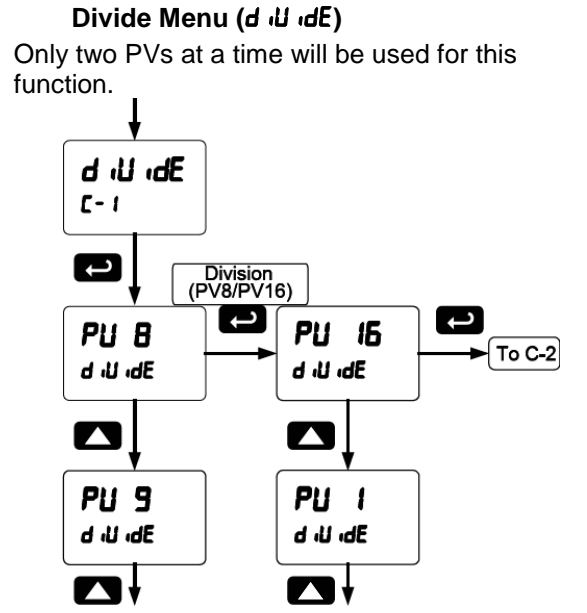
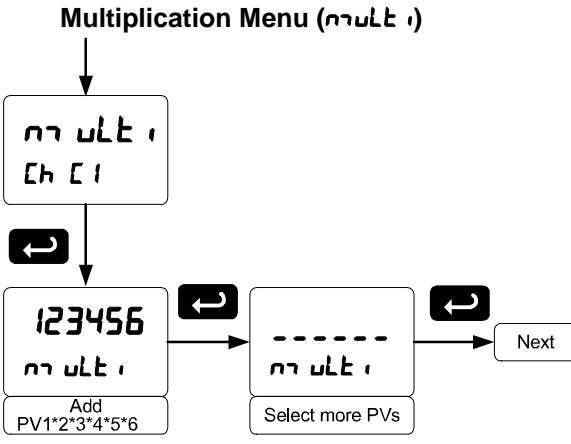
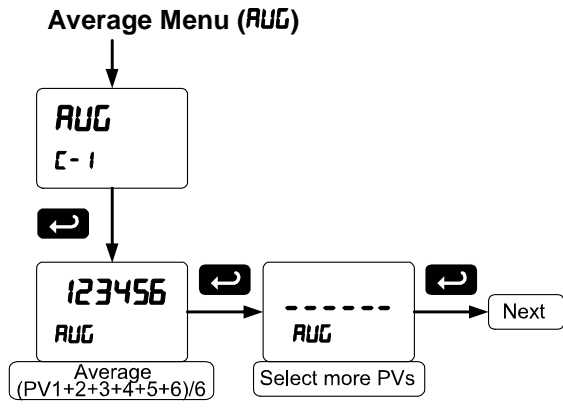
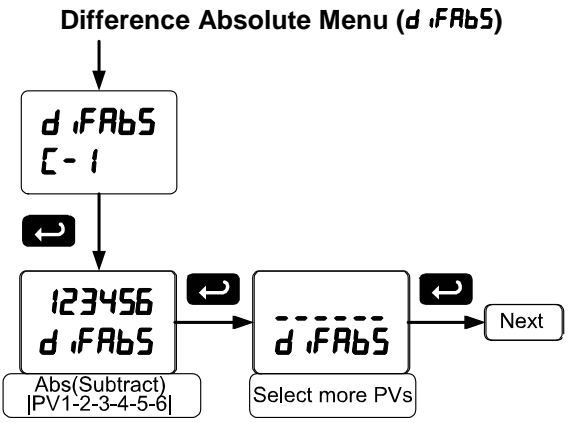
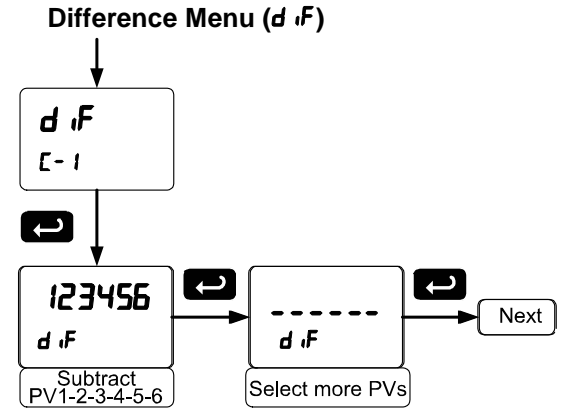
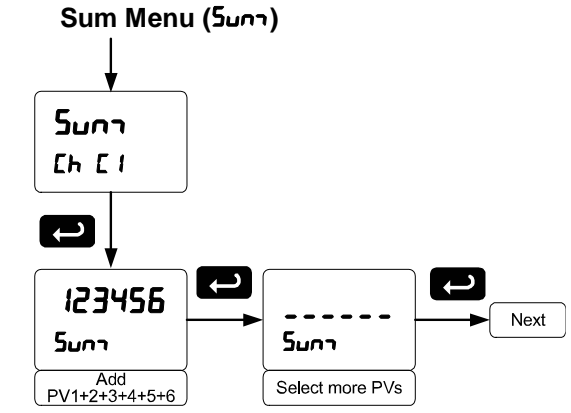

- Notes:
1. Press Up arrow to scroll through PV1 - PV16
 2. The first PV is the dividend and the second PV is the divisor.

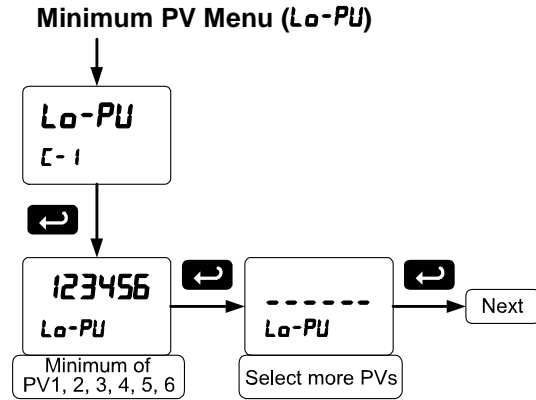
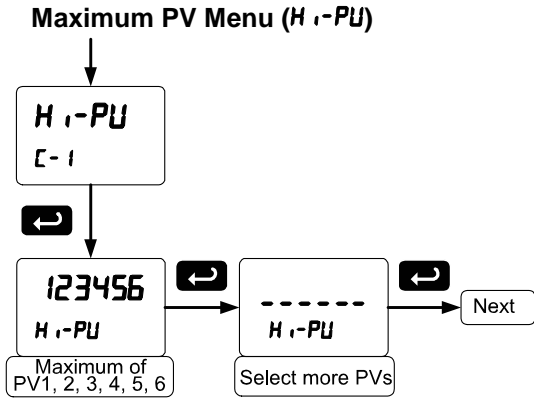

Draw Menu (drRuu)
Only two PVs at a time will be used for this function.

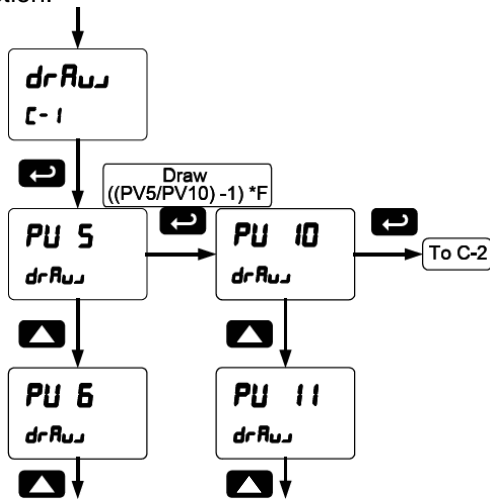

Notes:
1. Press Up arrow to scroll through PV1 - PV16
2. The first PV is the dividend and the second PV is the divisor.

Weighted Average Menu (uuRUG)
Only two PVs at a time will be used for this function

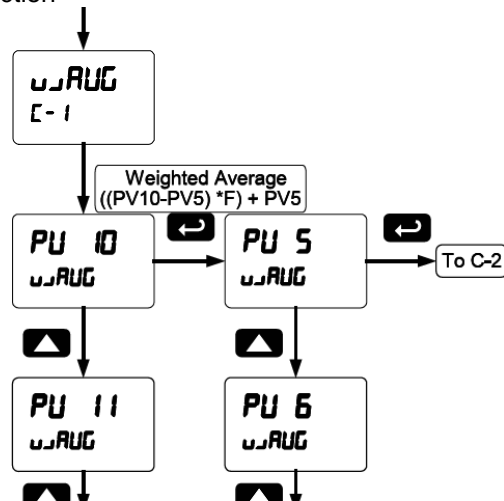

Notes:
1. Press Up arrow to scroll through PV1 - PV16
2. The first PV selected is the first PV in the equation.

Ratio Menu (rRt io)
Only two PVs at a time will be used for this function

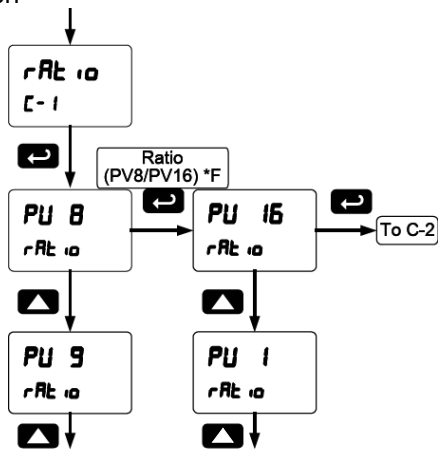

Notes:
1. Press Up arrow to scroll through PV1 - PV16
2. The first PV is the dividend and the second PV is the divisor.

Concentration Menu (ConcEn)
Only two PVs at a time will be used for this function

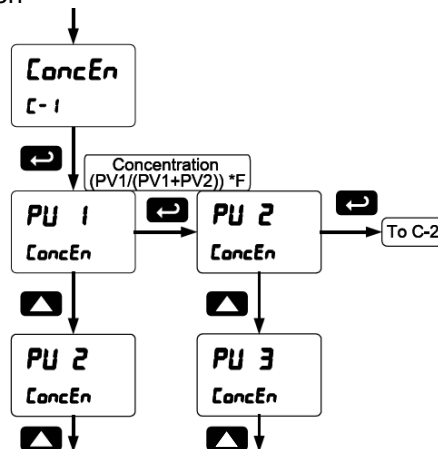

Notes:
1. Press Up arrow to scroll through PV1 - PV16
2. The first PV is the dividend and the Sum of the PVs is the divisor.

Low-Flow Cutoff (CutoFF)

The low-flow cutoff feature allows the scanner to be programmed so that the often unsteady output from a differential pressure transmitter, at low flow rates, always displays zero on the scanner. The cutoff value may be programmed from 0 to 999999. When the input data is below the cutoff value, the scanner will display zero. Programming the cutoff value to zero disables the cutoff feature.

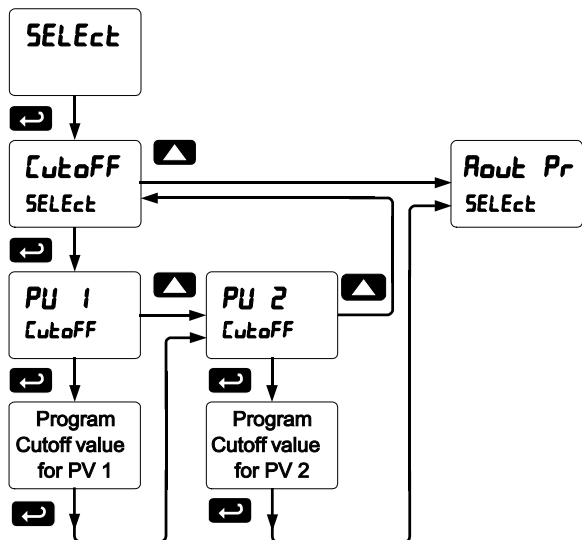

Analog Output Source Programming (RoutPr)

The 4-20 mA analog outputs can be programmed for source of data, overrange and underrange, absolute maximum and minimum output, and communications break values. They can also be recalibrated.

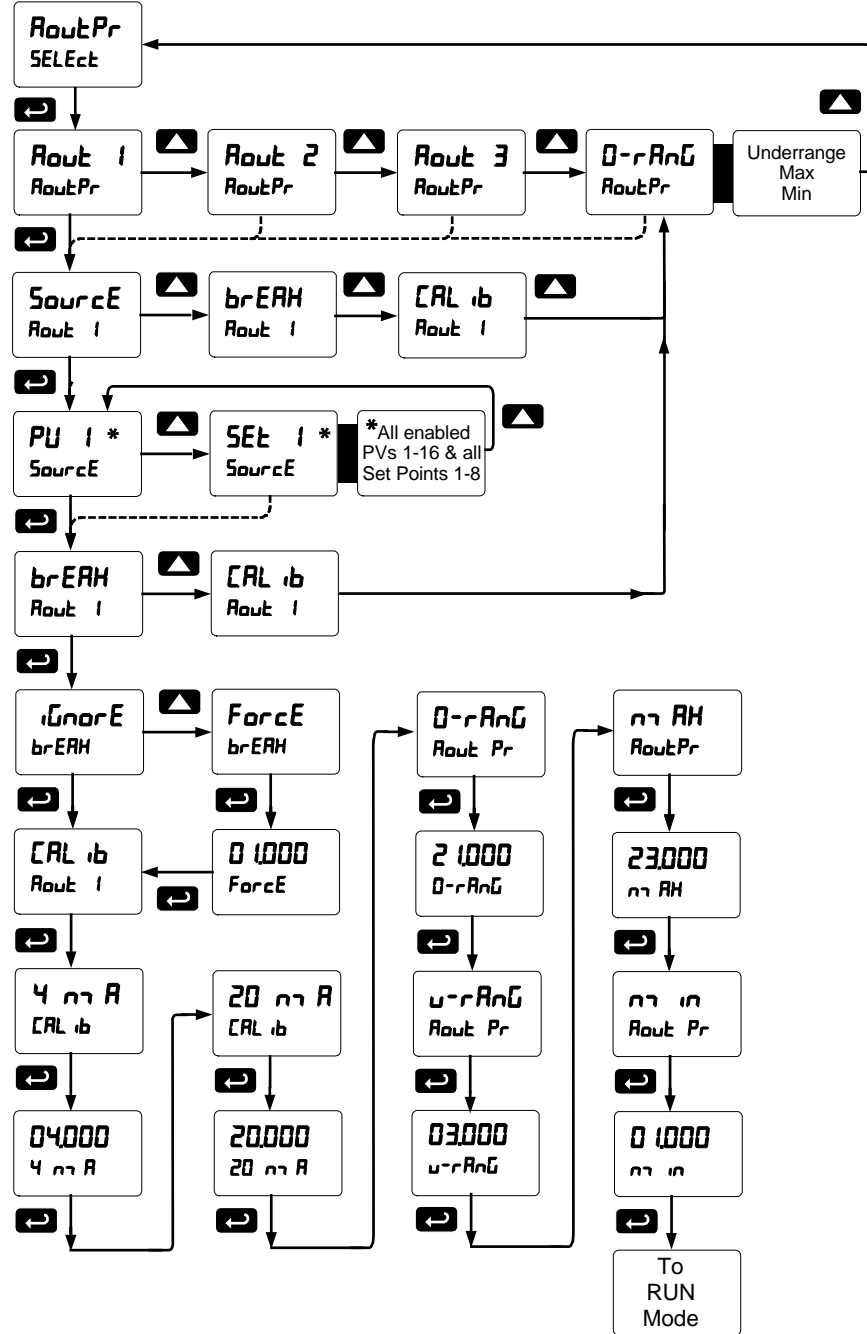

- To calibrate the analog outputs, follow the graphic above.
- The overrange and underrange values are the values that will be output when the display shows an overrange or underrange condition. This setting is common to all analog outputs.
- The maximum and minimum values are the absolute limits for the 4-20 mA output. This setting is common to all analog outputs.
- The communications break value determines the mA output when a Slave fails to reply to a command within the Response time.

User Menu (uSEr)

The *User* menu allows the user to assign the front panel function keys F1, F2, and F3, the digital input F4 (a digital input located on the signal input connector), and up to eight additional digital inputs to access most of the menus or to activate certain functions immediately (e.g. reset max & min, hold relay states, etc.). This allows the meter to be greatly customized for use in specialized applications.

Up to eight digital outputs can be assigned to a number of actions and functions executed by the meter (i.e. alarms, relay acknowledgement, reset max, min, or max & min, tare, and reset tare). The digital outputs can be used to trigger external alarms or lights to indicate these specific events.

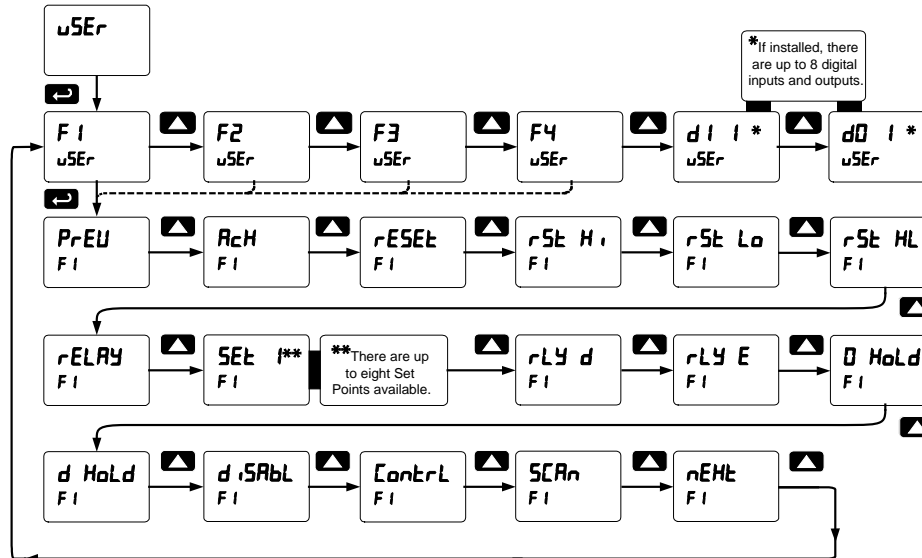

Function Keys & Digital I/O Available Settings

Display	Description
SCAn	Scan through all PVs
nEHt	Skip to the next PV
PrEU	Return to the previous PV
Rch	Acknowledge all active relays that are in a manual operation mode such as auto-manual or latching
rESEt	Directly access the reset menu
rSt Hi	Reset the stored maximum display values for all channels
rSt Lo	Reset the stored minimum display values for all channels
rSt HL	Reset the stored maximum & minimum display values for all channels
rELAY	Directly access the relay menu
SEt 1*	Directly access the set point menu for relay 1 (*through 8)
rLY d	Disable all relays until a button assigned to <i>enable relays (rLY E)</i> is pressed
rLY E	Enable all relays to function as they have been programmed
d Hold	Hold current relay states and analog output as they are until a button assigned to <i>enable relays (rLY E)</i> is pressed

Display	Description
d Hold	Hold the current display value, relay states and analog output momentarily while the function key or digital input is active. The process value will continue to be calculated in the background.
d iSRbL	Disable the selected function key or digital I/O
ContrL	Directly access the control menu
nEHt	Mimic the menu button functionality (digital inputs only)
r iHt	Mimic the right arrow/F1 button functionality (digital inputs only)
uP	Mimic the up arrow/F2 button functionality (digital inputs only)
EntEr	Mimic the enter/F3 button functionality (digital inputs only)
F on 1*	Force relay 1 (*through 4) into the on state. This function is used in conjunction with a digital input to achieve interlock functionality.
RLrn 1*	Provide indication when alarm 1 (*through 8) has been triggered (digital outputs only)

Digital Input Menu (d I I)

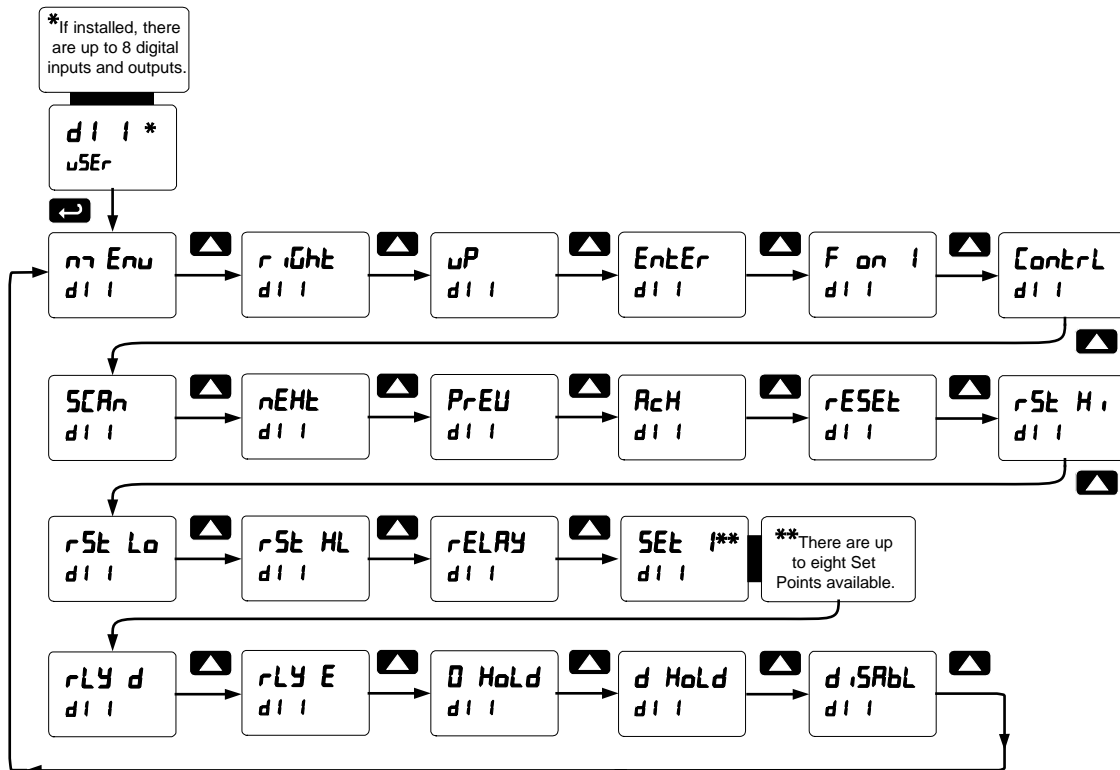

Digital Output Menu (d O I)

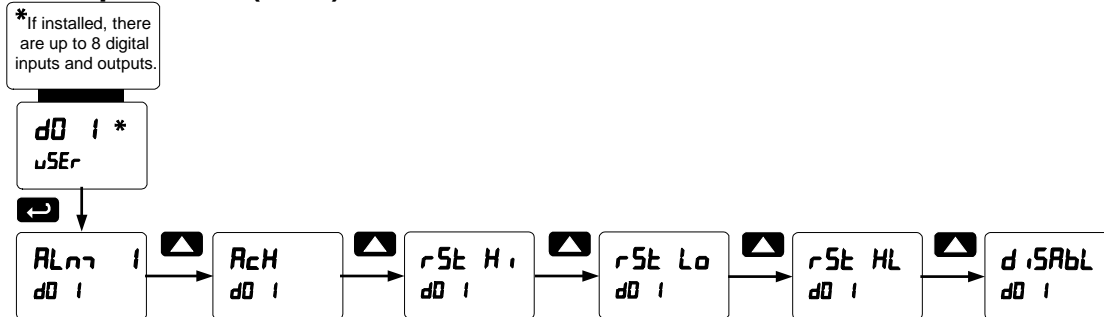

Reset Menu (rESEt)

The *Reset* menu is used to reset the maximum or minimum reading (peak or valley) reached by the process; both may be reset at the same time by selecting “reset high & low” (*rSt HL*). This is applied to all PVs and math channels.

Resetting is possible by going into the USER menu, selecting a function key or digital input, pressing ENTER to take you to the next level, then pressing the Up arrow until you arrive at the RESET menu. Press ENTER to assign the RESET menu to the selected function key or digital input. Now, when the scanner is in Run Mode, pressing the selected function key will take you to the RESET menu, where you can scroll through Reset Hi (Max), Reset Lo (Min), and Reset HiLo (Reset Max and Min), choosing what value to reset. You can also select the specific reset function (e.g. Reset HiLo) to the selected digital input or function key.

4-20 mA Output Calibration

- There is **no need to recalibrate** the 4-20 mA output when first received from the factory.
- The 4-20 mA outputs is **factory calibrated** prior to shipment. The calibration equipment is traceable to NIST standards.

The 4-20 mA output can be recalibrated in the field. A calibrated digital meter with an input range of at least 25 mA and a resolution of 1 μ A is recommended.



CAUTION!

If an uncalibrated meter or a meter with less resolution is used, the calibration of the 4-20 mA output could be adversely affected.

4-20 mA Output Calibration Procedure

1. Wire the PD6080/6081 4-20 mA output to a current loop that includes a power supply (internal or external 12 to 24 VDC), and the mA input on the digital meter. See page 20 for details.
2. Turn on all devices. Allow for a 15 to 30 minute warm-up.
3. Go to the Advanced Features menu, and navigate to the Analog Output Programming (**RoutPr**)/Calibration (**CAL** **ib**) menu and press **Enter**..
4. The display will show **4 mA**. The PD6080/6081 mA output should now be close to 4 mA. Press **Enter** and the display will show **04.000**. Enter the actual value read by the digital mA meter and press **Enter**.
5. The display will show **20 mA**. The PD6080/6081 mA output should now be close to 20 mA. Press **Enter** and the display will show **20.000**. Enter the actual value read by the digital mA meter and press **Enter**.
6. The PD6080/6081 will now calculate the calibration factors and store them.
7. Press Menu to exit and return to Run mode.

Input Calibration Menu (ICAL)

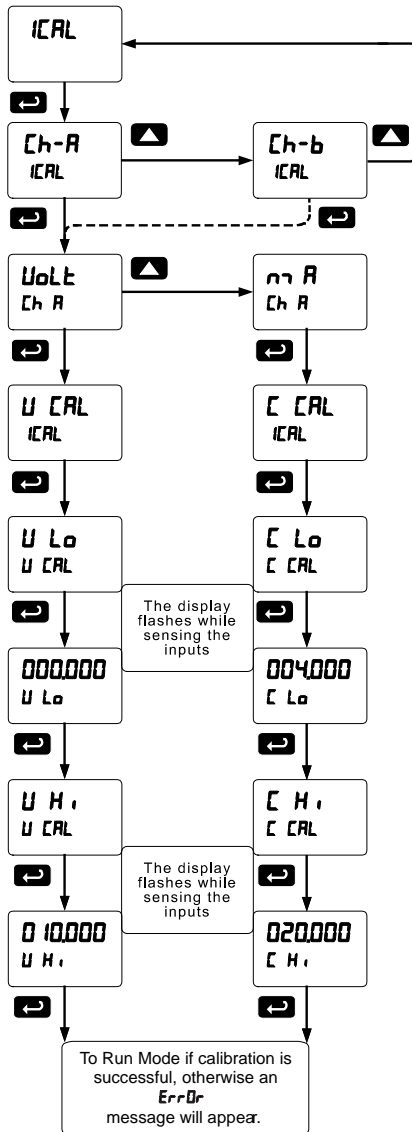

Recalibrating the Analog Input Channels (Ch-A & Ch-B)

The analog input channels are calibrated at the factory. If recalibration is needed, follow the flowchart menu above and the instructions below.

1. Enter the ICAL menu to calibrate channel A and channel B.
2. Select mA or Volt
3. Apply the low (4 mA or 0 V) and high (20 mA or 10 V) signals as requested.
4. Press Enter to accept the values entered or press Menu to exit calibration without saving the changes.

Error Message (Error)

An error message indicates that the calibration or scaling process was not successful. After the error message is displayed, the scanner reverts to input 2 during calibration or scaling and to input 1 during internal calibration, allowing the appropriate input signal to be applied or programmed.

The error message might be caused by any of the following:

1. Input signal is not connected to the proper terminals, or it is connected backwards.
2. Minimum input span requirements not maintained.

Input Range	Input 1 & Input 2 Span
4-20 mA	0.15 mA
±10 VDC	0.01 VDC

Troubleshooting

Due to the many features and functions of the scanner, it's possible that the setup of the scanner does not agree with what an operator expects to see. If the scanner is not working as expected, refer to the recommendations below.

Symptom	Check/Action
No display at all	Check power at power connector
Not able to change setup or programming, Locd is displayed	Scanner is password-protected, enter correct six-digit password to unlock
Scanner displays error message during scaling (Error)	Check: Input 2 must be greater than Input 1, Input 3 must be greater than Input 2, etc.
Scanner displays 1. 999999 2. -999999	Indicating overrange or underrange condition Check the input data value and scaling in <i>Setup</i> menu
Display stop scanning, LED indicator flashing	Check: 1. Stop on alarm feature has been enabled 2. Press PREV or NEXT to resume scanning
Displays brEAM message	Check: 1. RS-485 connection to slave devices 2. Slave Id, register number of slave devices 3. Baud rate and parity of all devices on the bus 4. Scanner Id must be different from other devices
Snooper mode not reading the PVs on the RS-485 bus	Check: 1. Increase Master's Transmit Delay (e.g. Snooper delay = 100ms, Master delay = 110ms) 2. Increase Snooper's byte-to-byte timeout 3. Decrease the slave device's transmit delay to <10ms 4. Snooper cannot read the same PV twice, check setup
Scanner experiencing faults and communication breaks	Check: 1. Increase response time (trESP) and/or transmit delay (trdLY). This may require some trial and error, as these are dependent upon the number of devices on the bus. 2. Internal Scan ID Modbus address. Addresses 256 (mA) or 257 (V) are used for Channel A, while Addresses 258 (mA) or 259 (V) are used for Channel B.
Scanner not communicating with ScanView software	Check: 1. Serial adapter and cable 2. Serial settings 3. Scanner address, baud rate, and transmit delay
Display does not respond to input data, reading a fixed number	Check: Display assignment, it might be displaying max/ min
Display reading is not accurate	Check: 1. PV Scaling 2. Check format selected: Dec or Ft&In
Relay operation is reversed	Check: 1. Fail-safe in <i>Setup</i> menu 2. Wiring of relay contacts
Relay and status LED do not respond to signal	Check: 1. Relay action in <i>Setup</i> menu 2. Set and reset points
Flashing relay status LEDs	Relays in manual control mode or relay interlock switches opened.
If the display locks up or the scanner does not respond at all	Cycle the power to reboot the microprocessor.
Other symptoms not described above	Call Technical Support for assistance.

Diagnostics Menu (d iRG)

The *Diagnostics* menu is located in the *Advanced Features* menu, to access *Diagnostics* menu see page 58. This menu allows the user to test the functionality of all the meter LEDs, check the meter's software and version information, and erase the MeterView Pro software installation files from the meter. Press the Enter button to view the settings and the Menu button to exit at any time.

Determining Software Version

To determine the software version of a scanner:

1. Go to the *Diagnostics* menu (d iRG) and press Enter button.
2. Press Up arrow button and scroll to Information menu (i n F o).
3. Press Enter to access the software number (S F t) and version (U E r) information. Write down the information as it is displayed. Continue pressing Enter until all the information is displayed.
4. The scanner returns to Run Mode after displaying all the settings.

Reset Scanner to Factory Defaults

When the parameters have been changed in a way that is difficult to determine what's happening, it might be better to start the setup process from the factory defaults.

Instructions to load factory defaults:

1. Enter the *Advanced Features* menu, see page 58.
2. Press Up arrow to go to *Diagnostics* menu
3. Press and hold Right arrow for three seconds, press Enter when display flashes **rESEt**.
Note: If Enter is not pressed within three seconds, the display returns to Run Mode.
4. The scanner goes through an initialization sequence (similar as on power-up), and loads the factory default settings.

Testing the Display LEDs

Enter the Diagnostic menu and press the ENTER button to get to the LED Test menu (LEd t). Press the ENTER button to activate the LED Test. The PD6080/6081 will cycle through all digits, decimal points, and relay indicators to enable the operator to see that all are functioning properly. Press the ENTER button again to access the Information menu (i n F o). Press the MENU button to return to Run Mode.

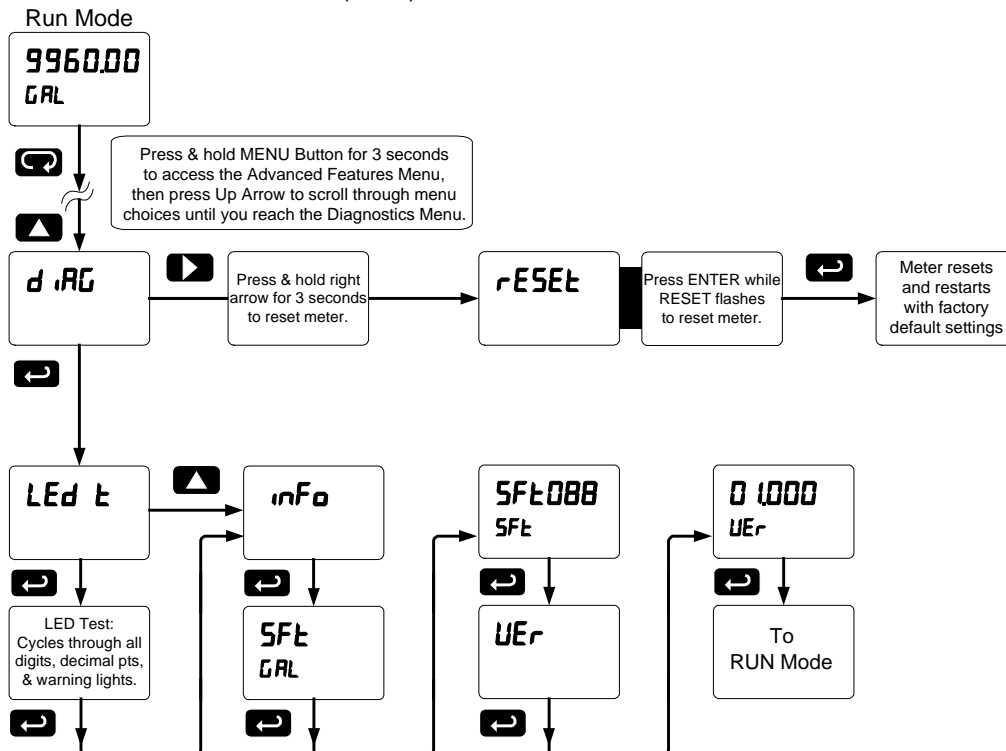

Scanner Operation

The PD6080/6081 scanner is capable of operating as a Modbus Master, Slave or Snooper. As a Slave, the PD6080/6081 requires connection to a Master device: PLC, DCS, etc. As a Master, the PD6080/6081 interfaces up to sixteen slave devices and can alternately display their Process Variables. As a Snooper it can be connected anywhere in the RS-485 bus to read any of the variables being requested by the Master device.







Four math channels (C1-C4) are available to perform operations on any PV or math channel, with adder and factor constants, and display the results. Engineering units or tags may be displayed with all PVs or math channels. Another level of Math functions can be performed on the resultant math channel Math2. For example, the operator can use the Math2 Channel to calculate the Sum of all other Math Channels, which may have each performed a different Math function.

The dual-line display can be customized by the user. Typically, the upper display is used to display the PV, while the lower display is used to display the tag for each PV.

Additionally, the scanner can be set up to display any input or math channel on the upper display and alternate between tag & units on the lower display. The relays and analog output can be programmed to operate based on any PV or math channel.

The scanner is capable of accepting two analog input channels (A and B) of either current (0-20 mA, 4-20 mA) or voltage signals (0-5 V, 1-5 V, 0-10 V, ± 10 V) and displaying these signals in engineering units from -99999 to 999999 (e.g. a 4-20 mA signal could be displayed as -50.000 to 50.000). The analog input channels must be mapped to PVs using the IDs 256-259.

Front Panel Buttons Operation

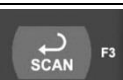
Button Symbol	Description
 	Press to enter, exit Programming Mode, or exit max/min readings
 	Press to move to the previous PV or math channel
 	Press to move to the next PV or math channel
 	Press once to pause scanning, press again to resume scanning

SafeTouch® Buttons

The ProtEX-MAX is equipped with four sensors that operate as through-glass buttons so that it can be programmed and operated without removing the cover (and exposing the electronics) in a hazardous area.

These buttons can be disabled for security by selecting DISABLE on the switch labeled NO-CONTACT BUTTONS located on the connector board.

To actuate a button, press one finger to the glass directly over the marked button area. Then retract finger more than three inches from the glass before pressing the next button. When the cover is removed, the four mechanical buttons located next to the sensors are used. The sensors are disabled when a mechanical button is pressed and will automatically be re-enabled after 60 seconds of inactivity.

The SafeTouch Buttons are designed to filter normal levels of ambient interference and to protect against false triggering, however, it is recommended that the SafeTouch Buttons be disabled (slide switch to LOCK) if there is an infrared interference source in line-of-sight to the display.

The SafeTouch Buttons are configured by default to duplicate the function of the front panel mechanical pushbuttons associated with the integrated meter. The symbols by each SafeTouch button correspond to a mechanical button as shown in the above table.

SafeTouch Button Tips:

- To the extent possible, install the display facing away from sunlight, windows, reflective objects and any sources of infrared interference.
- Keep the glass window clean.
- Tighten the cover securely.
- Use a password to prevent tampering.

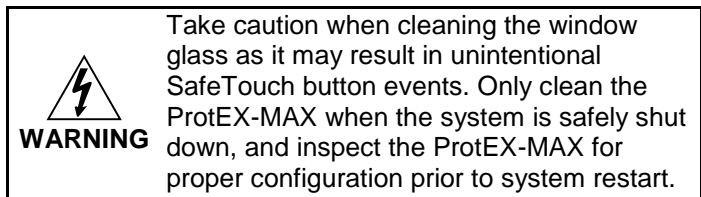

Function Keys Operation

During operation, the programmable function keys operate according to the way they have been programmed in the *Advanced Features – User* menu.

The table above shows the factory default settings for F1, F2, and F3.

F4 Operation

A digital input, F4, is standard on the scanner. This digital input is programmed identically to function keys F1, F2, and F3. The input is triggered with a contact closure to COM, or with an active low signal. During operation, F4 operates according to the way it has been programmed in the *Advanced Features – User* menu. See page 72 for details.

Maximum/Minimum Readings

The max & min readings (peak & valley) reached by the PVs or math channels can be displayed by assigning the display to max/min through the *Display Setup* menu.

A digital input should be programmed to reset the max & min readings.

Factory Defaults & User Settings

The following table shows the factory setting for most of the programmable parameters on the scanner.

Parameter	Display	Default Setting	Parameter	Display	Default Setting
Mode	<i>ModE</i>	Master	Adder (constant P)	<i>AddEr</i>	0.000
Function Code	<i>FunCod</i>	03	Factor (constant F)	<i>FActor</i>	1.000
PV Number	<i>PUnbr</i>	PV1-PV4 Enabled	Filter	<i>FILtEr</i>	
Slave ID PV1-16	<i>SLAVId</i>	001 - 016	Filter, PV 1	<i>Ch-A</i>	70
Register Number PV1-16	<i>rEGnBr</i>	40001	Filter, PV 2	<i>Ch-b</i>	70
Data Type PV1-16	<i>dAtA</i>	Float	Bypass, PV 1	<i>bYPASS</i>	0.2
Byte Order	<i>1234</i>	Big-endian	Bypass, PV 2	<i>bYPASS</i>	0.2
Polling Time	<i>t-POLL</i>	5.0 second	Round	<i>round</i>	1
Slave Response Timeout	<i>t-rESP</i>	10.0 second	Cutoff	<i>CuToFF</i>	
Serial	<i>SErIAL</i>		Cutoff value, PV 1	<i>Ch-A</i>	0.000 (disabled)
Scanner ID	<i>SCAnId</i>	246	Cutoff value, PV 2	<i>Ch-b</i>	0.000 (disabled)
Baud	<i>bAud</i>	9600	Display assignment	<i>dSPLAY</i>	
Parity	<i>PARitY</i>	Even	Line 1	<i>dPU</i>	Display PV
Byte-to-byte timeout	<i>t-bytE</i>	0.01 second	Line 2	<i>dTAG</i>	Display tag
Setup	<i>SEtUP</i>		Display intensity	<i>d-INtY</i>	8
Tag PV1-16	<i>tAG PU1</i>	PV 1 – PV 16	Relay 1 assignment	<i>PU 1</i>	PV 1
Units PV1-16	<i>UnItS PU1</i>	FEET	Relay 1 action	<i>Act 1</i>	Automatic
Units C1-4	<i>UnItS Ch C1</i>	UnitC1 – UnitC4	Relay 1 set point	<i>SEt 1</i>	1.000
Display Format PV1-16	<i>Formt PU1</i>	Dec (PD6080) Ft-In-16 (PD6081)	Relay 1 reset point	<i>rSEt 1</i>	0.500
Display Format C1-4	<i>Formt Ch C1</i>	Decimal	Relay 2 assignment	<i>PU 2</i>	PV 2
Display decimal point	<i>dISPdP</i>	ddd.ddd	Relay 2 action	<i>Act 2</i>	Automatic
Float decimal point	<i>FLoTdP</i>	ddd.ddd	Relay 2 set point	<i>SEt 2</i>	2.000
Number of points	<i>noPtS</i>	2 (all PVs and C channels)	Relay 2 reset point	<i>rSEt 2</i>	1.500
Scaling	<i>SCALE PU1</i>	All	Relay 3 assignment	<i>PU 3</i>	PV 3
Input 1	<i>inP 1</i>	0.000	Relay 3 action	<i>Act 3</i>	Automatic
Display 1	<i>dIS 1</i>	0.000	Relay 3 set point	<i>SEt 3</i>	3.000
Input 2	<i>inP 2</i>	10.000	Relay 3 reset point	<i>rSEt 3</i>	2.500
Display 2	<i>dIS 2</i>	10.000	Relay 4 assignment	<i>PU 4</i>	PV 4
Math, channel C1-4	<i>Summ</i>	Sum	Relay 4 action	<i>Act 4</i>	Automatic
			Relay 4 set point	<i>SEt 4</i>	4.000

Parameter	Display	Default Setting
Relay 4 reset point	<i>rSt 4</i>	3.500
Fail-safe relay 1	<i>FLS 1</i>	Off
Fail-safe relay 2	<i>FLS 2</i>	Off
Fail-safe relay 3	<i>FLS 3</i>	Off
Fail-safe relay 4	<i>FLS 4</i>	Off
On delay relay 1	<i>On 1</i>	0.0 sec
Off delay relay 1	<i>OFF 1</i>	0.0 sec
On delay relay 2	<i>On 2</i>	0.0 sec
Off delay relay 2	<i>OFF 2</i>	0.0 sec
On delay relay 3	<i>On 3</i>	0.0 sec
Off delay relay 3	<i>OFF 3</i>	0.0 sec
On delay relay 4	<i>On 4</i>	0.0 sec
Off delay relay 4	<i>OFF 4</i>	0.0 sec
Comm. break relay 1	<i>On</i>	On
Comm. break relay 2	<i>On</i>	On
Comm. break relay 3	<i>On</i>	On
Comm. break relay 4	<i>On</i>	On
Display 1 analog out	<i>d15 1</i>	00.00.00
Output 1 value	<i>Out 1</i>	4.000 mA
Display 2 analog out	<i>d15 2</i>	20.00.00
Output 2 value	<i>Out 2</i>	20.000 mA

Parameter	Display	Default Setting
Source analog output	<i>Source</i>	PV 1
Overrange output	<i>OverRng</i>	21.000 mA
Underrange output	<i>UndRng</i>	3.000 mA
Comm. break output	<i>brERR</i>	1.000 mA
Maximum output	<i>max RH</i>	23.000 mA
Minimum output	<i>min in</i>	1.000 mA
F1 function key	<i>F1</i>	Previous PV
F2 function key	<i>F2</i>	Next PV
F3 function key	<i>F3</i>	Scan/Pause
F4 function (digital input)	<i>F4</i>	Acknowledge relays
Digital input 1	<i>d1 1</i>	Menu
Digital input 2	<i>d1 2</i>	Right arrow
Digital input 3	<i>d1 3</i>	Up arrow
Digital input 4	<i>d1 4</i>	Enter
Digital output 1	<i>d0 1</i>	Alarm 1
Digital output 2	<i>d0 2</i>	Alarm 2
Digital output 3	<i>d0 3</i>	Alarm 3
Digital output 4	<i>d0 4</i>	Alarm 4
Password 1	<i>PASS 1</i>	000000 (unlocked)
Password 2	<i>PASS 2</i>	000000 (unlocked)
Password 3	<i>PASS 3</i>	000000 (unlocked)

Service



WARNINGS

- Installation and service should be performed only by trained service personnel. Service requiring replacement of internal sub-components must be performed at the factory.
- Disconnect from supply before opening enclosure. Keep cover tight while circuits are alive. Conduit seals must be installed within 18" (450mm) of the enclosure.
- Verify that the operating atmosphere of the instrument is consistent with the appropriate hazardous locations certifications.
- If the instrument is installed in a high voltage environment and a fault or installation error occurs, high voltage may be present on any lead
- Read all product labels completely and follow all instructions and requirements listed on the labels for installation or service.

If the enclosure is sound and undamaged, then only the internal electronics housing will need to be returned to the factory for service. Contact the factory for RMA number and return instructions.

Mounting Dimensions

All units: inches (mm)

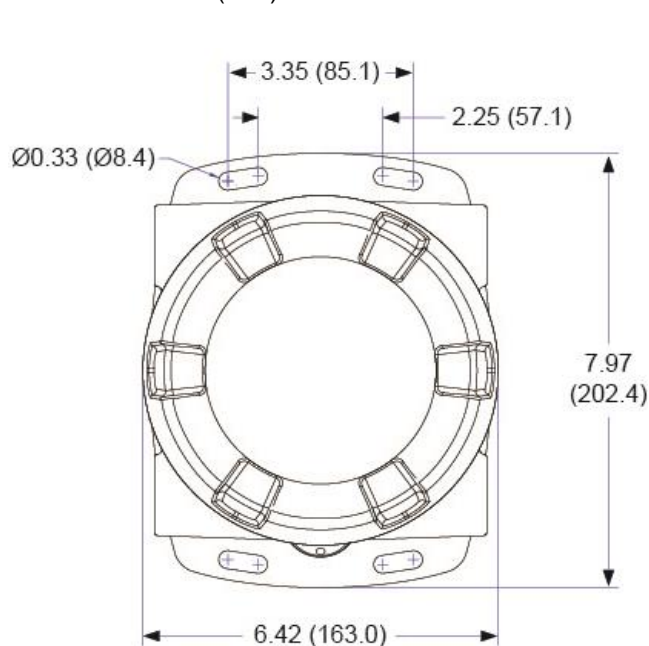

Figure 21: Enclosure Dimensions – Front View

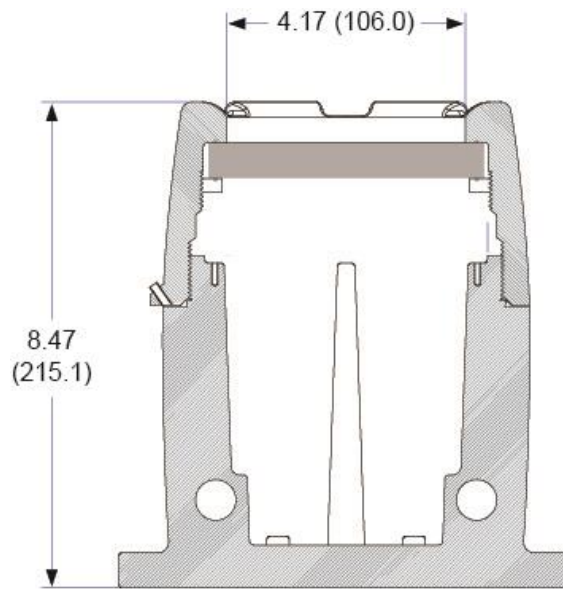

Figure 22: Enclosure Dimensions – Side Cross Section View



EU Declaration of Conformity

Issued in accordance with ISO/IEC 17050-1:2004 and ATEX Directive 2014/34/EU.

We,

Precision Digital Corporation
233 South Street
Hopkinton, MA 01748 USA

as the manufacturer, declare under our sole responsibility that the product(s),

Model PD8 ProtEX-MAX Series

to which this declaration relates, is in conformity with the European Union Directives shown below:

2014/35/EU	Low Voltage Directive
2014/34/EU	ATEX Directive
2014/30/EU	EMC Directive
2011/65/EU	RoHS Directive

This conformity is based on compliance with the application of harmonized or applicable technical standards and, when applicable or required, a European Union notified body certification.

Standards:

EN 55022:2007	EN 61000-6-2:2005	EN 60079-0:2009	EN 61000-6-4:2007
EN 60079-1:2007	EN 61010-1:2001	EN 60079-31:2008	EN 61326:2006

The standards EN 55022:2007, EN 60079-0:2009, EN 60079-1:2007, EN 60079-31:2008, EN 61000-6-4:2007, EN 61010-1:2001, and EN 61326:2006 are no longer harmonized. The requirements of these standards have been checked against the harmonized standard EN 55022:2010, EN 60079-0:2012+A11:2013, EN 60079-1:2014, EN 60079-31:2014, EN 61000-6-4:2007+A1:2011, EN 61010-1:2010, and EN 61326:2013 and there were no major technical changes affecting the latest technical knowledge for the products listed above.

EC Type Examination Certificate: Sira 12ATEX1182

Product Markings:  II 2 G D
Ex d IIC T* Gb
Ex tb IIIC T90°C Db IP68
Tamb = -40°C to +*°C (*T5 = 65°C, *T6 = 60°C)

ATEX Notified Body for EC Type Examination Certificate: Sira Certification Service, NB 0518
Unit 6, Hawarden Industrial Park
Hawarden, Deeside, CH5 3US, UK

ATEX Quality Assurance Notification No.: SIRA 10 ATEX M462

ATEX Notified Body for Quality Assurance: Sira Certification Service, NB 0518
Unit 6, Hawarden Industrial Park
Hawarden, Deeside, CH5 3US, UK

Signed for and on behalf of Precision Digital Corporation:

Name: Jeffrey Peters
Company: Precision Digital Corporation
Title: President
Date: 02/12/2018

Document No: DoC PD8 {021218}

How to Contact Precision Digital

- For Technical Support:
Call: (800) 610-5239 or (508) 655-7300
Fax: (508) 655-8990
Email: support@predig.com
- For Sales Support or to place an order:
Call: (800) 343-1001 or (508) 655-7300
Fax: (508) 655-8990
Email: sales@predig.com
- For the latest version of this manual please visit:
www.predig.com

PRECISION DIGITAL CORPORATION

233 South Street • Hopkinton MA 01748 USA
Tel (800) 343-1001 • Fax (508) 655-8990



www.predig.com