

# User's Guide

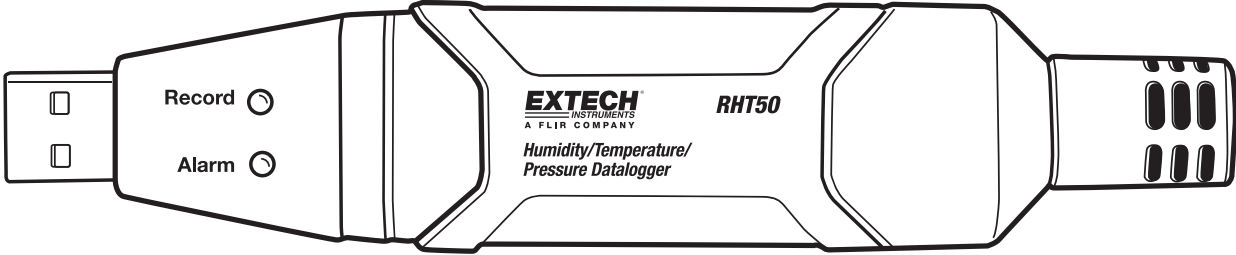

## Humidity + Temperature + Pressure Datalogger

### Model RHT50



## Introduction

---

Congratulations on your purchase of the Relative Humidity / Temperature / Pressure Datalogger. This datalogger can measure and store up to 10,000 readings. The user can easily configure the logging rate, high/low alarm and start-mode, and download the stored data by plugging the module into a PC's USB port and running the supplied PC software. Data can then be graphed, printed and exported to other applications. The data logger is supplied with a long-life lithium battery, which can typically allow logging for one year. This meter is shipped fully tested and calibrated and, with proper use, will provide years of reliable service.

## Features

---

- Memory 10,000 temperature, humidity and pressure readings
- Selectable data sampling rate: 1 minute to 18 hours
- Manual and automatic start
- Status Indication via Red/Yellow LED and Green LED
- USB Interface for Set-up and Data Download
- User-Programmable Alarm Thresholds
- Long battery life

## Description

---

1. USB connector
2. Alarm LED (red/yellow)
3. Record LED (green)
4. Start button
5. Battery cover latch
6. Tripod mount
7. RH, Temperature, Pressure sensors
8. Mounting bracket

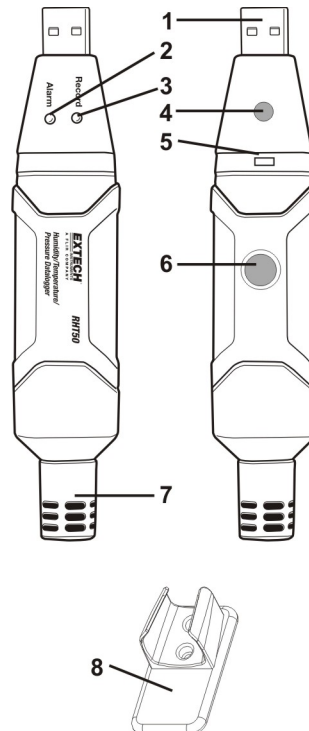

# Operation

---

## INSTALLING THE GRAPHING SOFTWARE

Install the supplied Windows™ PC Datalogger Software by placing the supplied program disk in the PC's CD-ROM drive. If the installation program does not automatically open and provide on-screen prompts, open and browse the CD-ROM drive, then find and double-click on the SETUP.EXE file included on the program disk. Follow the on-screen prompts to complete the installation.

Before running the graphing software, please connect the RHT50 to the PC and install the USB Driver software as described in the next section.

## INSTALLING THE USB DRIVER









Plug the RHT50 into an available USB port on the PC. If this is the first time that the RHT50 has been connected to the particular port on the PC, the following screen will appear:



Make sure the program disk is still in the PC CD-ROM drive. Select the 'recommended' installation and follow the on-screen prompts to complete the driver installation. If this is a repeat connection of the RHT50 to the USB port, the driver installation process will be automatically skipped.

Refer to the HELP utility in the software program for detailed instructions on using the software to download and process recorded data. The LED status guide provided below is offered for easy reference.

# LED STATUS GUIDE

LEDs		Meaning	
Record	Alarm		
		No LED No LED No LED	Logging not started Logging stopped * Battery discharged **
 Green		Green flash (single): Green flashes (five) Green flashes (six)	Logging indication ***** Reset Start Logging
	 Red	Red double flash every 30 sec. Red single flash Red flashes (six)	Low battery *** Logging, alarm event ***** Stop logging *
	 Yellow	Yellow flash every 20 seconds	Memory full *

- \* Connect the datalogger to the PC and download data
- \*\* Replace the battery, data will not be lost
- \*\*\* Logging will stop, data will remain in memory
- \*\*\*\* Occurs if an alarm is exceeded
- \*\*\*\*\* Flash cycle time is set from the software

## Specifications

	Range	Accuracy
<b>Relative Humidity</b>	0 to 20 and 80 to 100%	±5.0%
	20 to 80%	±3.5%
<b>Temperature</b>	-40 to 32°F and 104°F to 158°F -40 to 0°C and +40 to +70°C	±3.6°F/±2°C
	32°F to 104°F/0°C to +40°C	±1.8°F/±1°C
<b>Pressure</b>	950 to 1050hPa  (kPa, Bar, PSI)	Accuracy: ±0.25%FSO @ (25°C) Repeatability: ±0.25%Max±0.3%FSO Linearity/Hysteresis: ±0.24%FSO Temperature coefficient: ±0.1%FSO
	Notes: FSO: Full Scale Output 1psi = 68.947 mbar = 0.068947 bar 1 psi = 6894.7 Pa = 68.947 hPa = 6.8947 kPa	
<b>Resolution</b>	0.1%RH, 0.1°C/F, 0.1hPa	
<b>Data storage</b>	10,000 measurements	
<b>Logging rate</b>	Selectable sampling interval: From 1 minute up to 18 hours	
<b>Operating temperature</b>	-35 to 80°C (-31 to 176°F)	
<b>Battery type</b>	3.6V Lithium (1/2 AA) (SAFT LS14250, Xeno XL050F or equivalent)	
<b>Battery life</b>	1 year (typ.) depending on logging rate, ambient temperature, & use of Alarm LEDs	
<b>Dimensions/Weight</b>	101x25x23mm (4x1x.9") / 172g (6oz)	

# Battery Replacement

It is highly recommended that the battery be replaced every 12 months, or prior to logging critical data.

The RHT50 does not lose its stored readings when the battery weakens or when the battery is replaced; the data logging process will however be stopped and cannot be re-started until the battery has been replaced and the logged data has been downloaded to PC.

Use only 3.6V lithium batteries. Before replacing the battery, remove the datalogger from the PC. Follow diagrammatic steps below.

NOTE: Leaving the RHT50 plugged into the PC USB port longer than necessary will cause some of the battery capacity to be lost.

1. Unscrew the protective sensor cap counter-clockwise.
2. Remove the protective cap and safely set it aside.
3. While inserting a small flat blade screwdriver into the slot and applying moderate pressure to the locking tab, pull the front (USB side) of the RHT50 outward.
4. Completely disassemble the meter to access the battery compartment.
5. Insert battery.
6. Re-assemble the meter.
7. Replace the cap.
8. Hand-tighten the cap in a clockwise motion. Do not over tighten.

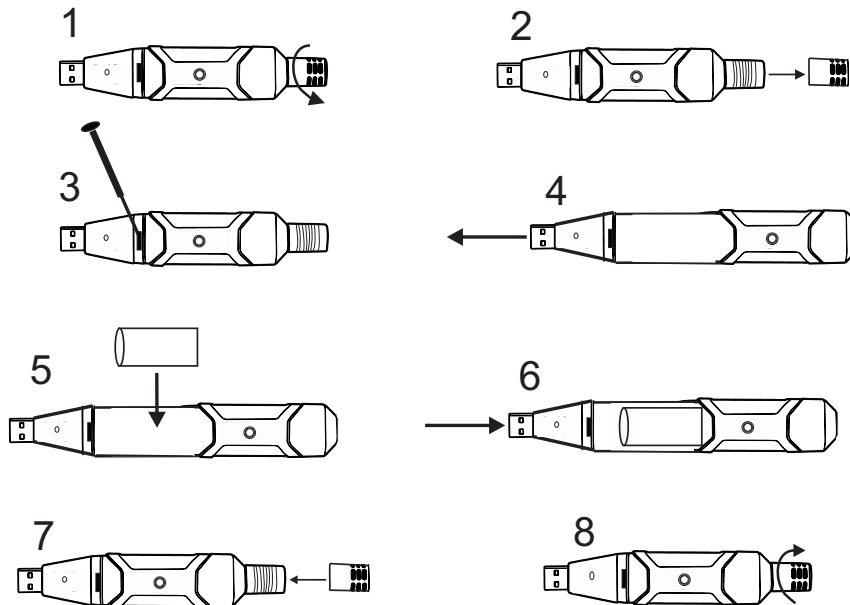

**WARNING:** Handle lithium batteries carefully, observe warnings on battery casing. Dispose of in accordance with local regulations.



You, as the end user, are legally bound (**EU Battery ordinance**) to return all used batteries, **disposal in the household garbage is prohibited!** You can hand over your used batteries / accumulators at collection points in your community or wherever batteries / accumulators are sold!

**Disposal:** Follow the valid legal stipulations in respect of the disposal of the device at the end of its lifecycle

**Copyright © 2014-2015 FLIR Systems, Inc.**

All rights reserved including the right of reproduction in whole or in part in any form  
ISO-9001 Certified

**www.extech.com**